

# КАК ПОЛУЧИТЬ ИНФОРМАЦИЮ О СВЕРЛАХ

## ● Как пользоваться страницами раздела

① Таблицы сформированы в соответствии с применением сверл.

ФОТОГРАФИЯ ПРОДУКЦИИ

ОПИСАНИЕ ПРОДУКЦИИ

ТИП ПРОДУКЦИИ

ДОПУСК НА ДИАМЕТР

ТИП ПРОДУКЦИИ

РАЗДЕЛ ПРОДУКЦИИ

Геометрия

**MPS**  
Тип с двойной ленточкой

● Типы сверлений 3-40 мм  
● MPS с двойной ленточкой для точной и надежной сверловки  
● Если сверло имеет отклонения для внутреннего сверления

UNIC VPC HPT X

3-5 C5 C6 C7 C8 C9 C10 C11 C12 C13 C14 C15 C16 C17 C18 C19 C20 C21 C22 C23 C24 C25 C26 C27 C28 C29 C30 C31 C32 C33 C34 C35 C36 C37 C38 C39 C40 C41 C42 C43 C44 C45 C46 C47 C48 C49 C50 C51 C52 C53 C54 C55 C56 C57 C58 C59 C60 C61 C62 C63 C64 C65 C66 C67 C68 C69 C70 C71 C72 C73 C74 C75 C76 C77 C78 C79 C80 C81 C82 C83 C84 C85 C86 C87 C88 C89 C90 C91 C92 C93 C94 C95 C96 C97 C98 C99 C100

● Тип 1 Цилиндрический хвостовик  
● Тип 2 Хвостовик с лыской

MPS-SL-DIN-C (из 3-5)  
MPS-L (из 8-40)

Диаметр D1 (мм)	Назначение	Обозначение	Размеры (мм)				Тип
			L1	L2	L3	D4	
3.0	3	MPS03005-DIN	62	20	36	6	2
3.0	4	MPS03005-DIN-C	62	20	36	6	1
3.0	5	MPS03008-DIN	66	28	36	6	2
3.0	6	MPS03008-DIN-C	66	28	36	6	1
3.0	7	MPS03008-L8C	74	34	36	6	1
3.0	8	MPS03008-L10C	80	40	36	6	1
3.0	9	MPS03004-L12C	86	46	36	6	1
3.0	10	MPS03004-L15C	92	52	36	6	1
3.0	11	MPS03004-L20C	110	70	36	6	1
3.0	12	MPS03004-L25C	125	85	36	6	1
3.0	13	MPS03004-L30C	140	100	36	6	1
3.0	14	MPS03004-L35C	159	116	36	6	1
3.0	15	MPS03004-L40C	174	131	36	6	1
3.05	3	MPS03055-DIN	62	20	36	6	2
3.05	4	MPS03055-DIN-C	62	20	36	6	1
3.05	5	MPS03105-DIN	62	20	36	6	2
3.05	6	MPS03105-DIN-C	62	20	36	6	1
3.05	7	MPS03105-L8C	66	28	36	6	1
3.05	8	MPS03105-L10C	66	28	36	6	1
3.05	9	MPS03105-L12C	66	28	36	6	1
3.05	10	MPS03104-L15C	87	47	36	6	1
3.05	11	MPS03104-L18C	80	40	36	6	1
3.05	12	MPS03104-L20C	94	54	36	6	1
3.05	13	MPS03104-L25C	122	82	36	6	1
3.05	14	MPS03104-L30C	139	99	36	6	1
3.05	15	MPS03104-L35C	157	117	36	6	1
3.05	16	MPS03104-L40C	176	135	36	6	1
3.05	17	MPS03104-L45C	191	151	36	6	1
3.05	18	MPS03104-L50C	206	167	36	6	1
3.05	19	MPS03104-L55C	221	183	36	6	1
3.05	20	MPS03104-L60C	236	199	36	6	1
3.05	21	MPS03104-L65C	251	215	36	6	1
3.05	22	MPS03104-L70C	266	231	36	6	1
3.05	23	MPS03104-L75C	281	247	36	6	1
3.05	24	MPS03104-L80C	296	263	36	6	1
3.05	25	MPS03104-L85C	311	279	36	6	1
3.05	26	MPS03104-L90C	326	295	36	6	1
3.05	27	MPS03104-L95C	341	311	36	6	1
3.05	28	MPS03104-L100C	356	327	36	6	1
3.05	29	MPS03104-L105C	371	343	36	6	1
3.05	30	MPS03104-L110C	386	359	36	6	1
3.05	31	MPS03104-L115C	401	375	36	6	1
3.05	32	MPS03104-L120C	416	391	36	6	1
3.05	33	MPS03104-L125C	431	407	36	6	1
3.05	34	MPS03104-L130C	446	423	36	6	1
3.05	35	MPS03104-L135C	461	439	36	6	1
3.05	36	MPS03104-L140C	476	455	36	6	1
3.05	37	MPS03104-L145C	491	471	36	6	1
3.05	38	MPS03104-L150C	506	487	36	6	1
3.05	39	MPS03104-L155C	521	503	36	6	1
3.05	40	MPS03104-L160C	536	519	36	6	1
3.05	41	MPS03104-L165C	551	535	36	6	1
3.05	42	MPS03104-L170C	566	551	36	6	1
3.05	43	MPS03104-L175C	581	567	36	6	1
3.05	44	MPS03104-L180C	596	583	36	6	1
3.05	45	MPS03104-L185C	611	599	36	6	1
3.05	46	MPS03104-L190C	626	615	36	6	1
3.05	47	MPS03104-L195C	641	631	36	6	1
3.05	48	MPS03104-L200C	656	647	36	6	1
3.05	49	MPS03104-L205C	671	663	36	6	1
3.05	50	MPS03104-L210C	686	679	36	6	1
3.05	51	MPS03104-L215C	701	695	36	6	1
3.05	52	MPS03104-L220C	716	711	36	6	1
3.05	53	MPS03104-L225C	731	727	36	6	1
3.05	54	MPS03104-L230C	746	743	36	6	1
3.05	55	MPS03104-L235C	761	759	36	6	1
3.05	56	MPS03104-L240C	776	775	36	6	1
3.05	57	MPS03104-L245C	791	791	36	6	1
3.05	58	MPS03104-L250C	806	807	36	6	1
3.05	59	MPS03104-L255C	821	823	36	6	1
3.05	60	MPS03104-L260C	836	839	36	6	1
3.05	61	MPS03104-L265C	851	855	36	6	1
3.05	62	MPS03104-L270C	866	871	36	6	1
3.05	63	MPS03104-L275C	881	887	36	6	1
3.05	64	MPS03104-L280C	896	899	36	6	1
3.05	65	MPS03104-L285C	911	915	36	6	1
3.05	66	MPS03104-L290C	926	929	36	6	1
3.05	67	MPS03104-L295C	941	945	36	6	1
3.05	68	MPS03104-L300C	956	959	36	6	1
3.05	69	MPS03104-L305C	971	975	36	6	1
3.05	70	MPS03104-L310C	986	989	36	6	1
3.05	71	MPS03104-L315C	1001	1005	36	6	1
3.05	72	MPS03104-L320C	1016	1019	36	6	1
3.05	73	MPS03104-L325C	1031	1035	36	6	1
3.05	74	MPS03104-L330C	1046	1049	36	6	1
3.05	75	MPS03104-L335C	1061	1065	36	6	1
3.05	76	MPS03104-L340C	1076	1079	36	6	1
3.05	77	MPS03104-L345C	1091	1095	36	6	1
3.05	78	MPS03104-L350C	1106	1109	36	6	1
3.05	79	MPS03104-L355C	1121	1125	36	6	1
3.05	80	MPS03104-L360C	1136	1139	36	6	1
3.05	81	MPS03104-L365C	1151	1155	36	6	1
3.05	82	MPS03104-L370C	1166	1169	36	6	1
3.05	83	MPS03104-L375C	1181	1185	36	6	1
3.05	84	MPS03104-L380C	1196	1199	36	6	1
3.05	85	MPS03104-L385C	1211	1215	36	6	1
3.05	86	MPS03104-L390C	1226	1229	36	6	1
3.05	87	MPS03104-L395C	1241	1245	36	6	1
3.05	88	MPS03104-L400C	1256	1259	36	6	1
3.05	89	MPS03104-L405C	1271	1275	36	6	1
3.05	90	MPS03104-L410C	1286	1289	36	6	1
3.05	91	MPS03104-L415C	1301	1295	36	6	1
3.05	92	MPS03104-L420C	1316	1319	36	6	1
3.05	93	MPS03104-L425C	1331	1335	36	6	1
3.05	94	MPS03104-L430C	1346	1349	36	6	1
3.05	95	MPS03104-L435C	1361	1365	36	6	1
3.05	96	MPS03104-L440C	1376	1379	36	6	1
3.05	97	MPS03104-L445C	1391	1395	36	6	1
3.05	98	MPS03104-L450C	1406	1409	36	6	1
3.05	99	MPS03104-L455C	1421	1425	36	6	1
3.05	100	MPS03104-L460C	1436	1439	36	6	1

● : Есть на складе. □ : Нет на складе, выполняется исключительно под заказ.

РЕЖИМЫ РЕЗАНИЯ > L003  
ТЕХНИЧЕСКИЕ ДАННЫЕ > N001

L035

**TAW**  
СВЕРЛЕНИЕ (СВЕРЛА СО СМЕННЫМИ ПЛАСТИНАМИ)

● Возможность резания кромок сверлирована для улучшения контроля за стружкой.  
● Специальные ребристые для точной установки пластины.  
● Пластина зажимается пластиной.

Технический рисунок сверла с пластинами.

■ ДЕРЖАВКА

Диаметр D1 (мм)	Длина D2 (мм)	Обозначение	Длина пластины L1 (мм)	Обозначение	Наличие	Размеры (мм)				Упаковка			
						L3	L4	L1	D4				
18.5	3	TAWSN1900S25	18.5	TAWNH18S0T	●	68	99	155	25	WS3045177	TKY10T	HPF4005	MK1KX
				TAWNH18S0T	●								
				TAWNH18S0T	●								
				TAWNH18S0T	●								
				TAWNH18S0T	●								
				TAWNH18S0T	●								
				TAWNH18S0T	●								
				TAWNH18S0T	●								
				TAWNH18S0T	●								
				TAWNH18S0T	●								
19.4	5	TAWMN1900S25	19.4	TAWNH19S0T	●	107	134	190	25	WS3045177	TKY10T	HPF4005	MK1KX
				TAWNH19S0T	●								
				TAWNH19S0T	●								
				TAWNH19S0T	●								
				TAWNH19S0T	●								
				TAWNH19S0T	●								
				TAWNH19S0T	●								
				TAWNH19S0T	●								
				TAWNH19S0T	●								
				TAWNH19S0T	●								
19.5	3	TAWSN2000S25	19.5	TAWNH19S0T	●	72	99	155	25	WS304518T	TKY10T	HPF4005	MK1KX
				TAWNH19S0T	●								
				TAWNH19S0T	●								
				TAWNH19S0T	●								
				TAWNH19S0T	●								
				TAWNH19S0T	●								
				TAWNH19S0T	●								
				TAWNH19S0T	●								
				TAWNH19S0T	●								
				TAWNH19S0T	●								
20.4	5	TAWMN2000S25	20.4	TAWNH20S0T	●	113	139	195	25	WS304518T	TKY10T	HPF4005	MK1KX
				TAWNH20S0T	●								
				TAWNH20S0T	●								
				TAWNH20S0T	●								
				TAWNH20S0T	●								
				TAWNH20S0T	●								
				TAWNH20S0T	●								
				TAWNH20S0T	●								
				TAWNH20S0T	●								
				TAWNH20S0T	●								
20.4	8	TAWLN2000S25	20.4	TAWNH20S0T	●	170	193	249					

# СВЕРЛИЛЬНЫЕ ИНСТРУМЕНТЫ

ОБОЗНАЧЕНИЕ ПРОДУКЦИИ .....	L002
ОПИСАНИЕ ОБОЗНАЧЕНИЙ .....	L003
СХЕМА ВЫБОРА СВЕРЛА .....	L004

## ТИПЫ СВЕРЛ

### МОНОЛИТНЫЕ ТВЕРДОСПЛАВНЫЕ СВЕРЛА

MSE .....	[Микро-сверла]	L008
MSP .....	[ЦЕНТРОВОЧНОЕ СВЕРЛО]	L011
MWS .....	[сверло с двумя ленточками с внутренним охлаждением]	L012
MWE .....	[Сверло с 2 ленточками]	L022
MPS1 .....	[сверло с двумя ленточками]	L028
MPS .....	[Сверла с 4 ленточками сверхдлинные]	L035
MSL .....	[Сверла с 2 ленточками сверхдлинные]	L050
MGS .....	[Однокромочные свёрла с внутренним охлаждением]	L055
MMS .....	[Уникальные свёрла для сверления нержавеющей стали]	L058
MNS .....	[Сверла для алюминия с 4 каналами для подвода СОЖ]	L072
MAE/MAS .....	[Высокоточные сверла для алюминия и чугуна]	L096
MHS .....	[Высокоточные сверла для твёрдых материалов]	L102
VCHSM .....	[Сверла для закаленных материалов твёрдостью до 65HRC]	L113

### СВЕРЛА СО СМЕННЫМИ ПЛАСТИНАМИ

STAW .....	[Сверла малого диаметра со сменной пластиной]	L115
TAW .....	[Сверла со сменной пластиной]	L124
MVX .....	[Сверла со сменными пластинами]	L135
TAF .....	[Сверла со сменными пластинами]	L139

### СВЕРЛА С НАПАЙНЫМИ ПЛАСТИНАМИ

BRS .....	[Сверла с напайными пластинами]	L150
BRM .....	[Сверла с напайными пластинами]	L152
BRA .....	[Сверла с напайными пластинами]	L154

### HSS СВЕРЛА

#### VIOLET СВЕРЛА

VAPDS .....	[Быстрорежущие HSS-Co короткие свёрла для стали]	L158
VAPDM .....	[Быстрорежущие HSS-Co средние свёрла для стали]	L163
VAPDSSUS .....	[Быстрорежущие HSS-Co короткие свёрла для нержавеющей стали]	L167
VAPDMSUS .....	[Быстрорежущие HSS-Co средние свёрла для нержавеющей стали]	L173
VSD .....	[Быстрорежущие HSS-Co длинные сверла для нержавеющей стали]	L180
VAPDSCB .....	[Сверло HSS-Co для рассверливания]	L182

### ДЛЯ УГЛЕПЛАСТИКА

MCS .....	[Сверла для высококачественной обработки CFRP]	L185
-----------	--	------

#### \*Алфавитный указатель

L154 BRA  
L152 BRM  
L150 BRS  
L147 JFS (Втулка)  
L096 MAE  
L096 MAS  
L185 MCS  
L055 MGS  
L102 MHS  
L012 MINI-MWS  
L058 MMS  
L072 MNS

L035 MPS  
L028 MPS1  
L008 MSE  
L050 MSL  
L135 MVX  
L022 MWE  
L011 MSP  
L115 STAW  
L118 STAW (ПЛАСТИНЫ)  
L139 TAF  
L145 TAF (ПЛАСТИНЫ)  
L124 TAW

L129 TAW (ПЛАСТИНЫ)  
L163 VAPDM  
L173 VAPDMSUS  
L158 VAPDS  
L182 VAPDSCB  
L167 VAPDSSUS  
L113 VCHSM  
L180 VSD

# ОБОЗНАЧЕНИЕ ПРОДУКЦИИ

## ОБОЗНАЧЕНИЕ СВЕРЛ

**MW**

**E**

**0300**

**S**

**A**

Наименование сверла	Тип охлаждения	Диаметр	L/D	Тип хвостовик
<b>MPS1</b> : MPS1 Сверла <b>MW</b> : MWE/MWS Сверла <b>MSL</b> : MSL Сверла <b>MP</b> : MPS Сверла <b>MA</b> : MAE/MAS Сверла <b>MS</b> : MSE Сверла <b>MM</b> : MMS Сверла <b>MN</b> : MNS Сверла <b>MH</b> : MHS Сверла <b>MC</b> : MCS Сверла	<b>E</b> : Наружное охлаждение <b>S</b> : Внутреннее охлаждение	<b>Пример</b> <b>0050</b> → $\phi$ 0.5 <b>0300</b> → $\phi$ 3.0	<b>S</b> : 2D <b>M</b> : 3D <b>L</b> : 5D (MAE / MAS Тип=6D) <b>X</b> : 12D <b>X8DB</b> : 8D <b>X10DB</b> : 10D <b>X15DB</b> : 15D <b>X20DB</b> : 20D <b>X25DB</b> : 25D <b>X30DB</b> : 30D	<b>A</b> : Хвостовик того же диаметра, что и сверло. <b>B</b> : Хвостовик постоянного диаметра.

\*Исключения частично включаются.

**VA**

**PD**

**S**

**SUS**

**D0300**

Наименование сверла	Область применения	Длина винтовой канавки	Обрабатываемый материал	Диаметр
<b>VA</b> : Сверла высокой точности с покрытием VIOLET (Высококачественная, Быстрорежущая сталь) <b>V</b> : VIOLET Сверла	<b>SD</b> : Прямое сверло общего применения <b>PD</b> : Для высокоточной обработки	<b>S</b> : Короткий <b>M</b> : Средний	<b>SUS</b> : Для нержавеющей стали	<b>Пример</b> <b>D0300</b> → $\phi$ 3.0 <b>D0050</b> → $\phi$ 0.5

\*Исключения частично включаются.

# ОПИСАНИЕ ОБОЗНАЧЕНИЙ

## Материал режущего инструмента



**Сверх-микрозернистый карбид**  
Сверх-микрозернистый карбид используется в качестве основы.



**Высококачественная высоколегированная быстрорежущая сталь**  
Высококачественная высоколегированная быстрорежущая сталь используется в качестве основного материала.



**Кобальтовая быстрорежущая сталь**  
В качестве основы используется кобальтовая быстрорежущая сталь.



**Быстрорежущая сталь**  
В качестве основы используется быстрорежущая сталь.

## Покрытие



**Покрытие MIRACLE**  
Оригинальное разработанное покрытие MIRACLE (Al, Ti)N. Также применяется для сухого резания.



**Покрытие DP**  
Новое поколение покрытий подходящие для следующих материалов.



**Покрытие UP**



**Покрытие VIOLET**  
Увеличенная стойкость в 2-3 раза более чем покрытие TiN



**Алмазное покрытие**  
Оригинальное алмазное CVD покрытие. Подходит для сверления CFRP.

## Подточка перемычки



**X заострение перемычки**  
X заострение перемычки используется на поперечной кромке сверла.



**XR заострение перемычки**  
XR заострение перемычки используется на поперечной кромке сверла.

## Угол и острота режущей кромки



**Двойной угол в плане**  
Указывает угол между режущими кромками сверла при вершине.

# СХЕМА ВЫБОРА СВЕРЛА

Материал режущего инструмента	Диапазон размеров	Глубина сверления (l/d)	Код	Охлаждение	Покрытие	Обрабатываемый материал						Форма	Номер страницы	
						Р	Н	М	К	Н	S		Размеры	Режимы резания
						Углеродистая сталь, Перфрелевая сталь	Закалённая сталь	Нержавеющая сталь	Чугун	Лёгкий сплав	Жаропрочные сплавы			
Монолитные Твердосплавные Сверла	φ0.1 -φ0.99	5-12	<b>MSE</b>	НАРУЖНОЕ	VP	○	○	○	○	○	○		L008	L009
	φ0.5 -φ2.95	1-30	<b>MINI-MWS</b>	ВНУТРЕННЕЕ	VP	○	○	○	○	○	○		L012	L016
	φ3.0 -φ20.0	3, 5	<b>MPS1</b> <small>NEW</small>		VP	○	○	○	○	○	○		L028	L033
	φ3.0 -φ20.0	3-40	<b>MPS</b> <small>MIRACLE SIGMA</small>		VP	○	○	○	○	○	○		L035	L053
	φ3.0 -φ14.0	20-30	<b>MSL</b>		VP	○	○	○	○	○	○		L050	L053
	φ3.0 -φ20.0	2, 3	<b>MWE</b>		НАРУЖНОЕ	VP	○	○	○	○	○	○		L022
	φ0.95 -φ12.0	1-31	<b>MHS</b>	ВНУТРЕННЕЕ	VP	○	○	○	○	○	○		L102	L110
	φ2.5 -φ16.0	3	<b>VCHSM</b>	НАРУЖНОЕ	VC	○	○	○	○	○	○		L113	L114
	φ3.0 -φ20.0	3, 5	<b>MMS</b>	ВНУТРЕННЕЕ	DP	○	○	○	○	○	○		L058	L070
	φ0.7 -φ3.0	-80	<b>MGS</b>	ВНУТРЕННЕЕ	-	○	○	○	○	○	○		L055	L056
	φ3.0 -φ16.0	3	<b>MAE</b>	НАРУЖНОЕ	-	○	○	○	○	○	○		L096	L101
	φ3.0 -φ16.0	3, 6	<b>MAS</b>	ВНУТРЕННЕЕ	-	○	○	○	○	○	○		L096	L101
	φ3.0 -φ20.0	3-30	<b>MNS</b>		-	○	○	○	○	○	○		L072	L093
	φ4.366 -φ12.725	3	<b>MCS</b>		DC	Для Углепластика							L185	L186

Материал режущего инструмента	Диапазон размеров	Глубина сверления (l/d)	Код	Охлаждение	Покрытие	Обрабатываемый материал						Форма	Номер страницы	
						Р	Н	М	К	Н	S		Размеры	Режимы резания
						Углеродистая сталь, легированная сталь	Закалённая сталь	Нержавеющая сталь	Чугун	Лёгкий сплав	Жаропрочные сплавы			
Быстрорежущая сталь	φ0.5 –φ13.0	2–3	<b>VAPDS</b>	НАРУЖНОЕ		<input type="radio"/>	<input type="radio"/>	<input type="radio"/>	<input type="radio"/>	<input type="radio"/>	<input type="radio"/>		L158	L162
	φ0.5 –φ32.0	3–6	<b>VAPDM</b>			<input type="radio"/>	<input type="radio"/>	<input type="radio"/>	<input type="radio"/>	<input type="radio"/>	<input type="radio"/>		L163	L166
	φ0.5 –φ20.0	2–3	<b>VAPDSSUS</b>			<input type="radio"/>	<input checked="" type="radio"/>	<input type="radio"/>	<input type="radio"/>	<input type="radio"/>	<input type="radio"/>		L167	L179
	φ0.5 –φ13.0	3–6	<b>VAPDMSUS</b>			<input type="radio"/>	<input checked="" type="radio"/>	<input type="radio"/>	<input type="radio"/>	<input type="radio"/>	<input type="radio"/>		L173	L179
	φ0.5 –φ13.0	3–6	<b>VSD</b>			<input type="radio"/>	<input type="radio"/>	<input type="radio"/>	<input type="radio"/>	<input type="radio"/>	<input type="radio"/>		L180	L181
	φ2.0 –φ32.0	2–3	<b>VAPDSCB</b>			<input type="radio"/>	<input type="radio"/>	<input type="radio"/>	<input type="radio"/>	<input type="radio"/>	<input type="radio"/>		L182	L184
Сменными	φ10.0 –φ18.4	1.5–8	<b>STAW</b>	ВНУТРЕННЕЕ		<input type="radio"/>	<input type="radio"/>	<input checked="" type="radio"/>	<input type="radio"/>	<input type="radio"/>	<input type="radio"/>		L115	L122
	φ14.0 –φ30.4	3–8	<b>TAW</b>			<input type="radio"/>	<input type="radio"/>	<input checked="" type="radio"/>	<input type="radio"/>	<input type="radio"/>	<input type="radio"/>		L124	L133
	φ17.0 –φ33.0	2–9	<b>MVX</b>			–	<input type="radio"/>	<input type="radio"/>	<input checked="" type="radio"/>	<input type="radio"/>	<input type="radio"/>		L135	L138
	φ12.0 –φ56.0	2–4	<b>TAF</b>		–	<input type="radio"/>	<input checked="" type="radio"/>	<input checked="" type="radio"/>	<input type="radio"/>	<input type="radio"/>	<input type="radio"/>		L139	L146
Напайными	φ14.0 –φ30.0	3	<b>BRS</b>			<input type="radio"/>	<input checked="" type="radio"/>	<input type="radio"/>	<input type="radio"/>	<input type="radio"/>	<input type="radio"/>		L150	L151
	φ14.0 –φ30.0	5	<b>BRM</b>			<input type="radio"/>	<input checked="" type="radio"/>	<input type="radio"/>	<input type="radio"/>	<input type="radio"/>	<input type="radio"/>		L152	L153
	φ8.0 –φ40.0	3	<b>BRA</b>			<input type="radio"/>	<input type="radio"/>	<input type="radio"/>	<input type="radio"/>	<input type="radio"/>	<input type="radio"/>		L154	L156

◎ : 1-я рекомендация / ○ : 2-я рекомендация

# СЕРИИ СВЕРЛ

МОНОЛИТНЫЕ ТВЕРДОСПЛАВНЫЕ СВЕРЛА

NEW



**MPS** (Тип с двойной ленточкой)

**MPS1** (Тип с двойной ленточкой)

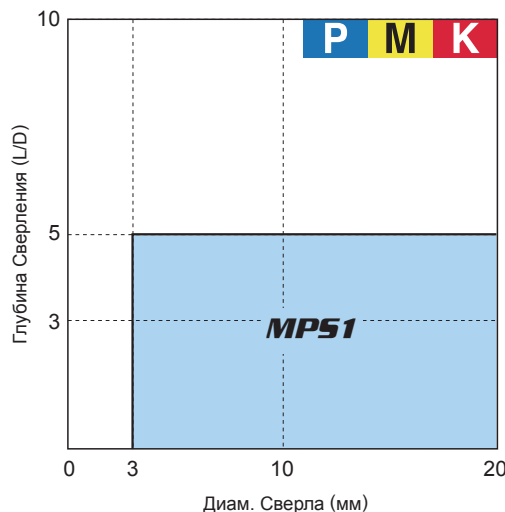
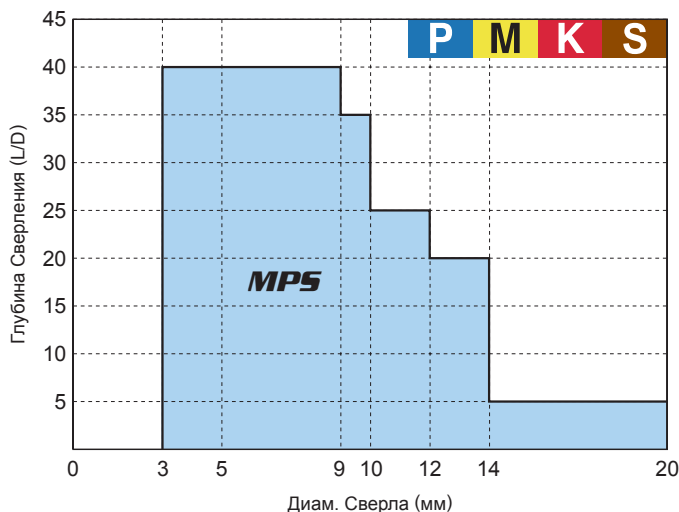

МОНОЛИТНЫЕ ТВЕРДОСПЛАВНЫЕ СВЕРЛА

МОНОЛИТНЫЕ ТВЕРДОСПЛАВНЫЕ СВЕРЛА

**MSL** (Стандартный тип)

**MINI-MWS, MGS**

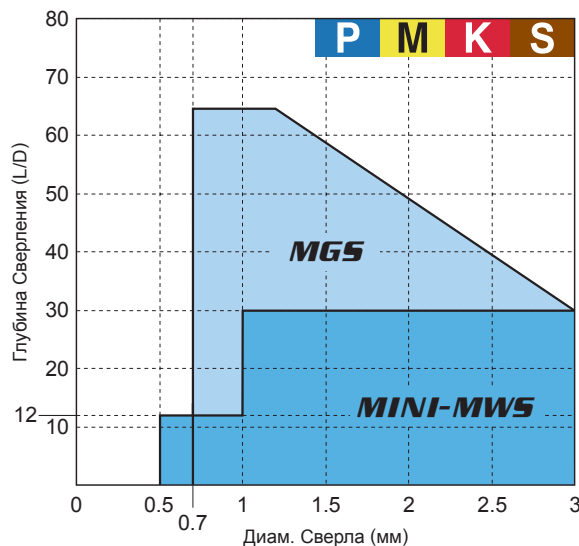
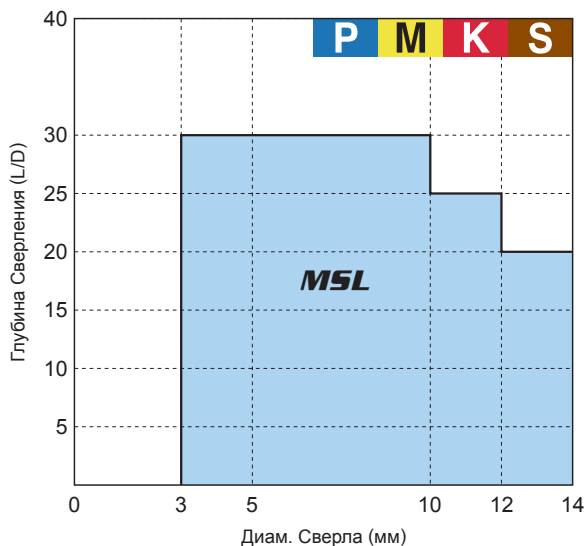

МОНОЛИТНЫЕ ТВЕРДОСПЛАВНЫЕ СВЕРЛА

**MWE/MWS, MWS...DB** (СВЕРХДЛИННЫЕ)

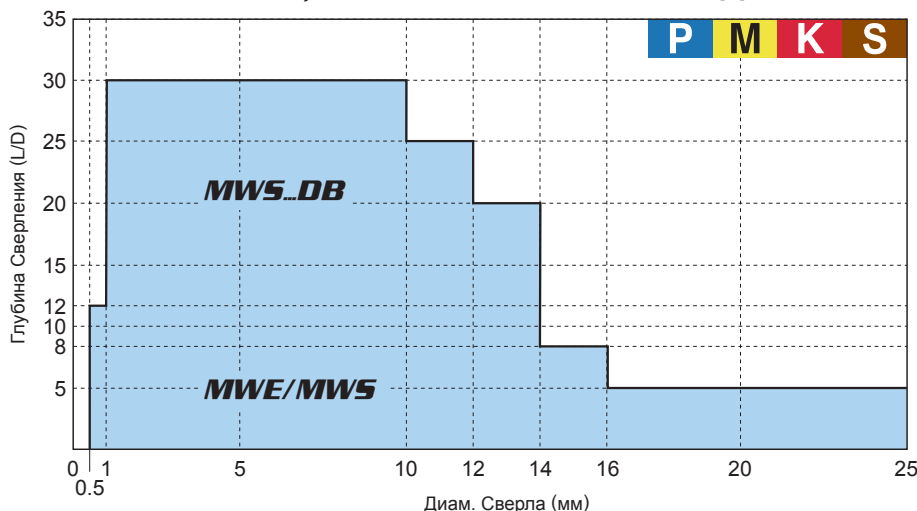

## МОНОЛИТНЫЕ ТВЕРДОСПЛАВНЫЕ СВЕРЛА

### **MMS** (Для нержавеющей стали)

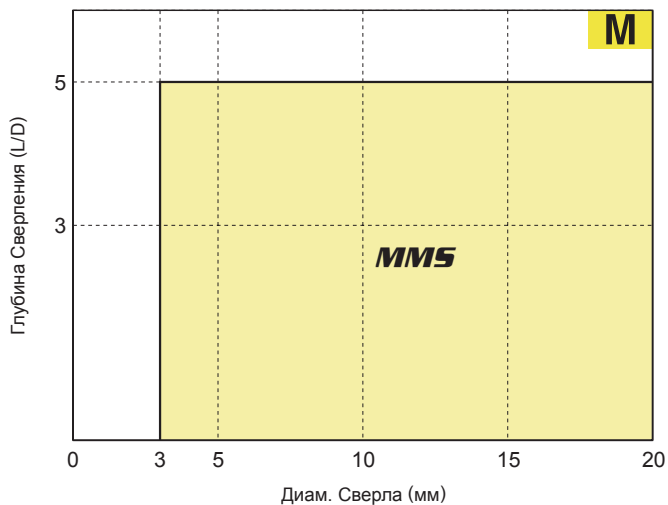

## МОНОЛИТНЫЕ ТВЕРДОСПЛАВНЫЕ СВЕРЛА

### **MNS** (Для обработки алюминиевых сплавов)

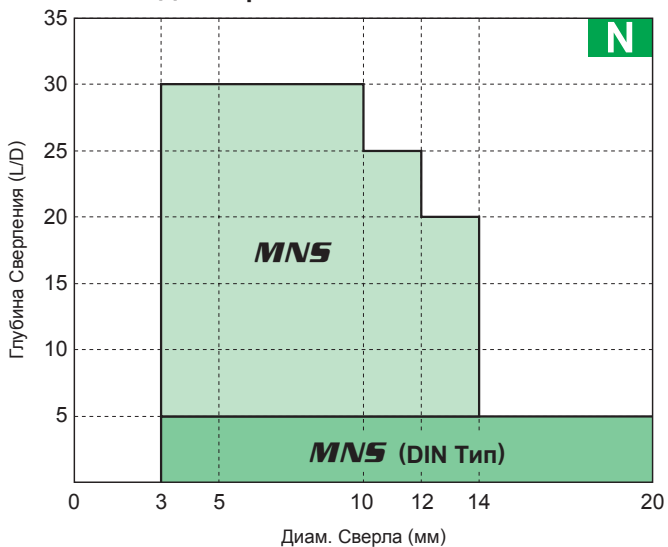

## МОНОЛИТНЫЕ ТВЕРДОСПЛАВНЫЕ СВЕРЛА

### **MHS** (Для производства штапов и пресс-форм)

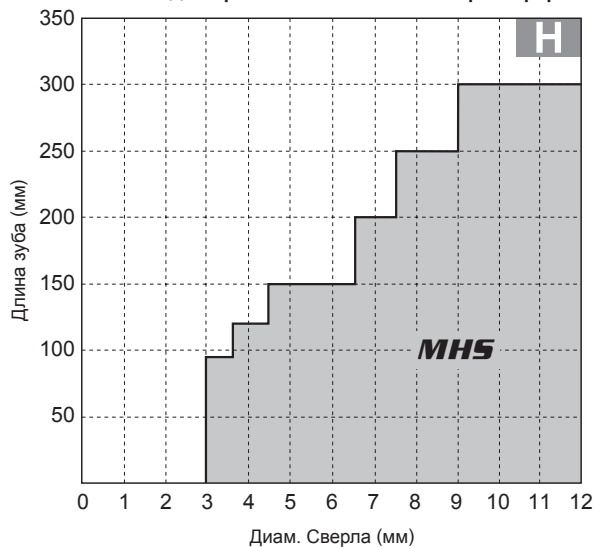

## СВЕРЛА СО СМЕННЫМИ ПЛАСТИНАМИ

### **S-TAW, TAW**

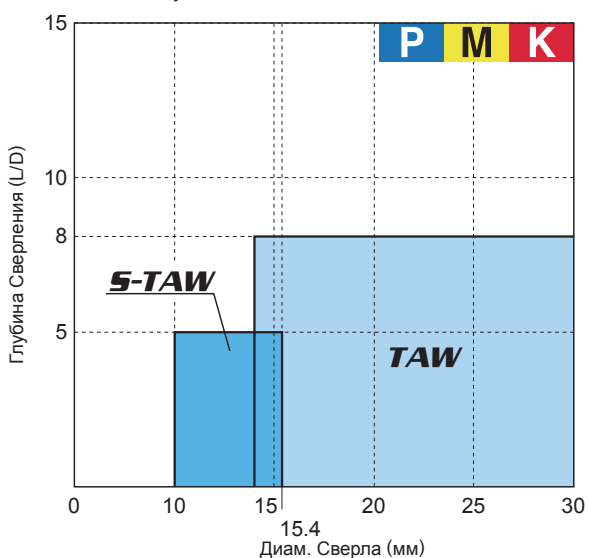

# СВЕРЛЕНИЕ (МОНОЛИТНЫЕ ТВЕРДОСПЛАВНЫЕ СВЕРЛА)

ТВЕРДЫЙ  
СПЛАВ

## MSE

- Широкая канавка предотвращает забивание стружкой.
- Стабильная обработка малым диаметром.

Углеродистая сталь Легированная сталь	Закалённая сталь	Нержавеющая сталь	Чугун	Лёгкий сплав	Жаропрочные сплавы
○	○	○	○	○	○

	0.1 ≤ D1 ≤ 3
	0 -0.009
	0
	-0.006

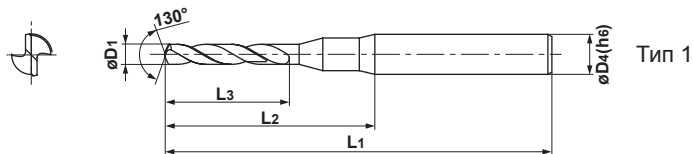

Тип 1

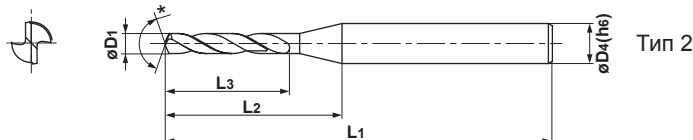

Тип 2

\*Диам. сверла  $\phi$  0.30—1.59 : 130°  
 $\phi$  1.60—2.50 : 140°

(Примечание) Сверла MSE предназначены для использования с термопатронами.

Диам. сверла D1 (мм)	Охлаждение (Внут./Нар.)	Наличие		Обозначение	Размеры (мм)				Тип	Диам. сверла D1 (мм)	Охлаждение (Внут./Нар.)	Наличие		Обозначение	Размеры (мм)				Тип
		VP20MF	VP15TF		L3	L2	L1	D4				VP20MF	VP15TF		L3	L2	L1	D4	
0.10	Нар.	★		MSE0010SB	1.2	9.7	38	3	1	0.44	Нар.	★		MSE0044SB	7	12.0	38	3	2
0.11	Нар.	★		0011SB	1.2	9.7	38	3	1	0.45	Нар.	★		0045SB	7	12.0	38	3	2
0.12	Нар.	★		0012SB	1.4	9.7	38	3	1	0.46	Нар.	★		0046SB	7	11.9	38	3	2
0.13	Нар.	★		0013SB	1.4	9.7	38	3	1	0.47	Нар.	★		0047SB	7	11.9	38	3	2
0.14	Нар.	★		0014SB	2	9.7	38	3	1	0.48	Нар.	★		0048SB	7	11.9	38	3	2
0.15	Нар.	★		0015SB	2	9.7	38	3	1	0.49	Нар.	★		0049SB	7	11.9	38	3	2
0.16	Нар.	★		0016SB	2	9.7	38	3	1	0.50	Нар.	★		0050SB	7	11.9	38	3	2
0.17	Нар.	★		0017SB	2	9.7	38	3	1	0.51	Нар.	★		0051SB	7	11.8	38	3	2
0.18	Нар.	★		0018SB	2	9.7	38	3	1	0.52	Нар.	★		0052SB	7	11.8	38	3	2
0.19	Нар.	★		0019SB	2	9.7	38	3	1	0.53	Нар.	★		0053SB	7	11.8	38	3	2
0.20	Нар.	★		0020SB	2.5	9.7	38	3	1	0.54	Нар.	★		0054SB	7	11.8	38	3	2
0.21	Нар.	★		0021SB	2.5	9.7	38	3	1	0.55	Нар.	★		0055SB	7	11.8	38	3	2
0.22	Нар.	★		0022SB	2.5	9.7	38	3	1	0.56	Нар.	★		0056SB	7	11.8	38	3	2
0.23	Нар.	★		0023SB	2.5	9.7	38	3	1	0.57	Нар.	★		0057SB	7	11.7	38	3	2
0.24	Нар.	★		0024SB	3	9.7	38	3	1	0.58	Нар.	★		0058SB	7	11.7	38	3	2
0.25	Нар.	★		0025SB	3	9.7	38	3	1	0.59	Нар.	★		0059SB	7	11.7	38	3	2
0.26	Нар.	★		0026SB	3	9.7	38	3	1	0.60	Нар.	★		0060SB	7	11.7	38	3	2
0.27	Нар.	★		0027SB	3	9.7	38	3	1	0.61	Нар.	★		0061SB	7	11.7	38	3	2
0.28	Нар.	★		0028SB	3	9.7	38	3	1	0.62	Нар.	★		0062SB	7	11.6	38	3	2
0.29	Нар.	★		0029SB	3	9.7	38	3	1	0.63	Нар.	★		0063SB	7	11.6	38	3	2
0.30	Нар.		★	0030SB	5	10.2	38	3	2	0.64	Нар.	★		0064SB	7	11.6	38	3	2
0.31	Нар.		★	0031SB	5	10.2	38	3	2	0.65	Нар.	★		0065SB	7	11.6	38	3	2
0.32	Нар.		★	0032SB	5	10.2	38	3	2	0.66	Нар.	★		0066SB	7	11.6	38	3	2
0.33	Нар.		★	0033SB	5	10.2	38	3	2	0.67	Нар.	★		0067SB	7	11.5	38	3	2
0.34	Нар.		★	0034SB	6	11.2	38	3	2	0.68	Нар.	★		0068SB	7	11.5	38	3	2
0.35	Нар.		★	0035SB	6	11.1	38	3	2	0.69	Нар.	★		0069SB	7	11.5	38	3	2
0.36	Нар.		★	0036SB	6	11.1	38	3	2	0.70	Нар.	★		0070SB	8	12.5	38	3	2
0.37	Нар.		★	0037SB	6	11.1	38	3	2	0.71	Нар.	★		0071SB	8	12.5	38	3	2
0.38	Нар.		★	0038SB	6	11.1	38	3	2	0.72	Нар.	★		0072SB	8	12.5	38	3	2
0.39	Нар.		★	0039SB	6	11.1	38	3	2	0.73	Нар.	★		0073SB	8	12.4	38	3	2
0.40	Нар.		★	0040SB	7	12.1	38	3	2	0.74	Нар.	★		0074SB	8	12.4	38	3	2
0.41	Нар.		★	0041SB	7	12.0	38	3	2	0.75	Нар.	★		0075SB	8	12.4	38	3	2
0.42	Нар.		★	0042SB	7	12.0	38	3	2	0.76	Нар.	★		0076SB	8	12.4	38	3	2
0.43	Нар.		★	0043SB	7	12.0	38	3	2	0.77	Нар.	★		0077SB	8	12.4	38	3	2

(Примечание) Пожалуйста, свяжитесь с нами если Вы не нашли нужную геометрию в данном каталоге (могут быть заказаны другие диаметры и длины).

★ : Со склада в Японии.

L008

Диам. сверла D1 (мм)	Охлаждение (Внут./Нар.)	Наличие		Обозначение	Размеры (мм)				Тип
		VP20MF	VP15TF		L3	L2	L1	D4	
0.78	Нар.	★		MSE0078SB	8	12.3	38	3	2
0.79	Нар.	★		0079SB	8	12.3	38	3	2
0.80	Нар.	★		0080SB	10	14.3	38	3	2
0.81	Нар.	★		0081SB	10	14.3	38	3	2
0.82	Нар.	★		0082SB	10	14.3	38	3	2
0.83	Нар.	★		0083SB	10	14.3	38	3	2
0.84	Нар.	★		0084SB	10	14.2	38	3	2
0.85	Нар.	★		0085SB	10	14.2	38	3	2
0.86	Нар.	★		0086SB	10	14.2	38	3	2
0.87	Нар.	★		0087SB	10	14.2	38	3	2
0.88	Нар.	★		0088SB	10	14.2	38	3	2

Диам. сверла D1 (мм)	Охлаждение (Внут./Нар.)	Наличие		Обозначение	Размеры (мм)				Тип
		VP20MF	VP15TF		L3	L2	L1	D4	
0.89	Нар.	★		MSE0089SB	10	14.1	38	3	2
0.90	Нар.	★		0090SB	10	14.1	38	3	2
0.91	Нар.	★		0091SB	10	14.1	38	3	2
0.92	Нар.	★		0092SB	10	14.1	38	3	2
0.93	Нар.	★		0093SB	10	14.1	38	3	2
0.94	Нар.	★		0094SB	10	14.0	38	3	2
0.95	Нар.	★		0095SB	10	14.0	38	3	2
0.96	Нар.	★		0096SB	10	14.0	38	3	2
0.97	Нар.	★		0097SB	10	14.0	38	3	2
0.98	Нар.	★		0098SB	10	14.0	38	3	2
0.99	Нар.	★		0099SB	10	14.0	38	3	2

## РЕКОМЕНДУЕМЫЕ РЕЖИМЫ РЕЗАНИЯ

Диам. сверла (мм)	Скорость резания (м/мин)	Частота вращения (мин <sup>-1</sup> )	Малоуглеродистые стали (≤180HB)			Углеродистая сталь Легированная сталь (180–280HB)				
			Ск10	Ск45, 41CrMo4	Ск45, 41CrMo4	Ск45, 41CrMo4	Ск45, 41CrMo4	Ск45, 41CrMo4	Ск45, 41CrMo4	
			Поддача (мин.—макс.) (мм/об)	Шаг (мм)	Поддача (мм/мин)			Поддача (мин.—макс.) (мм/об)	Шаг (мм)	Поддача (мм/мин)
0.1	6	20000	0.002 (0.001–0.003)	0.02	40	6	20000	0.002 (0.001–0.003)	0.02	40
0.12	8	20000	0.002 (0.001–0.003)	0.02	40	8	20000	0.002 (0.001–0.003)	0.02	40
0.16	10	20000	0.002 (0.001–0.003)	0.02	40	10	20000	0.002 (0.001–0.003)	0.02	40
0.2	13	20000	0.003 (0.002–0.004)	0.04	60	13	20000	0.003 (0.002–0.004)	0.04	60
0.25	16	20000	0.003 (0.002–0.004)	0.04	60	16	20000	0.003 (0.002–0.004)	0.04	60
0.32	20	20000	0.004 (0.003–0.005)	0.05	80	20	20000	0.004 (0.003–0.005)	0.05	80
0.4	25	20000	0.004 (0.003–0.005)	0.05	80	25	20000	0.004 (0.003–0.005)	0.05	80
0.5	31	20000	0.006 (0.005–0.007)	0.1	120	31	20000	0.006 (0.005–0.007)	0.1	120
0.63	40	20000	0.008 (0.006–0.01)	0.1	160	40	20000	0.008 (0.006–0.01)	0.1	160
0.8	50	20000	0.02 (0.015–0.025)	0.3	400	50	20000	0.015 (0.012–0.018)	0.3	300
0.99	62	20000	0.04 (0.03–0.05)	0.3	800	62	20000	0.02 (0.015–0.025)	0.3	400

Диам. сверла (мм)	Скорость резания (м/мин)	Частота вращения (мин <sup>-1</sup> )	Углеродистая сталь Легированная сталь (280–350HB)			Предварительно закалённая сталь (35–45HRC)				
			36CrNiMo4	36CrNiMo4	36CrNiMo4	X36CrMo17	X36CrMo17	X36CrMo17	X36CrMo17	X36CrMo17
			Поддача (мин.—макс.) (мм/об)	Шаг (мм)	Поддача (мм/мин)			Поддача (мин.—макс.) (мм/об)	Шаг (мм)	Поддача (мм/мин)
0.1	6	20000	0.002 (0.001–0.003)	0.02	40	6	20000	0.002 (0.001–0.003)	0.02	40
0.12	8	20000	0.002 (0.001–0.003)	0.02	40	8	20000	0.002 (0.001–0.003)	0.02	40
0.16	10	20000	0.002 (0.001–0.003)	0.02	40	10	20000	0.002 (0.001–0.003)	0.02	40
0.2	13	20000	0.003 (0.002–0.004)	0.04	60	13	20000	0.003 (0.002–0.004)	0.04	60
0.25	16	20000	0.003 (0.002–0.004)	0.04	60	16	20000	0.003 (0.002–0.004)	0.04	60
0.32	20	20000	0.004 (0.003–0.005)	0.05	80	20	20000	0.004 (0.003–0.005)	0.05	80
0.4	25	20000	0.004 (0.003–0.005)	0.05	80	25	20000	0.004 (0.003–0.005)	0.05	80
0.5	31	20000	0.006 (0.005–0.007)	0.1	120	31	20000	0.006 (0.005–0.007)	0.1	120
0.63	40	20000	0.008 (0.006–0.01)	0.1	160	40	20000	0.008 (0.006–0.01)	0.1	160
0.8	50	20000	0.015 (0.012–0.018)	0.3	300	50	20000	0.015 (0.012–0.018)	0.3	300
0.99	62	20000	0.02 (0.015–0.025)	0.3	400	62	20000	0.02 (0.015–0.025)	0.3	400

(Примечание)

- При сверлении до  $\phi 0.3$  мм рекомендуется использовать центровочное сверло.
- Измените режимы резания в зависимости от жесткости станка и заготовки.
- При глубине сверления свыше 5d снизьте установленную ранее глубину ступенчатого сверления.
- Для сверления при выше указанных режимах резания рекомендуется использовать СОЖ (разбавленную в пропорции 1:20).
- Материал, труднообрабатываемый с наружным охлаждением, маркируется знаком " - " в приведенной выше таблице. Рекомендуется использовать сверла типа MWS или VAPDSSUS.

# СВЕРЛЕНИЕ (МОНОЛИТНЫЕ ТВЕРДОСПЛАВНЫЕ СВЕРЛА)

# MSE

- Широкая канавка предотвращает забивание стружкой.
- Стабильная обработка малым диаметром.

## РЕКОМЕНДУЕМЫЕ РЕЖИМЫ РЕЗАНИЯ

Обрабатываемый материал	Аустенитная нержавеющая сталь (≤200НВ) X5CrNi1810, X5CrNiMo17-12-2						Серый чугун (≤350МПа) GG30					
	Диам. сверла (мм)	Скорость резания (м/мин)	Частота вращения (мин <sup>-1</sup> )	Подача (мин. — макс.) (мм/об)	Шаг (мм)	Подача (мм/мин)	Скорость резания (м/мин)	Частота вращения (мин <sup>-1</sup> )	Подача (мин. — макс.) (мм/об)	Шаг (мм)	Подача (мм/мин)	
<b>0.1</b>	6	20000	0.002 (0.001—0.003)	0.02	40	6	20000	0.002 (0.001—0.003)	0.02	40		
<b>0.12</b>	8	20000	0.002 (0.001—0.003)	0.02	40	8	20000	0.002 (0.001—0.003)	0.02	40		
<b>0.16</b>	10	20000	0.002 (0.001—0.003)	0.02	40	10	20000	0.002 (0.001—0.003)	0.02	40		
<b>0.2</b>	11	18000	0.003 (0.002—0.004)	0.04	54	13	20000	0.003 (0.002—0.004)	0.04	60		
<b>0.25</b>	14	18000	0.003 (0.002—0.004)	0.04	54	16	20000	0.003 (0.002—0.004)	0.04	60		
<b>0.32</b>	15	15000	0.004 (0.003—0.005)	0.05	60	20	20000	0.004 (0.003—0.005)	0.05	80		
<b>0.4</b>	19	15000	0.004 (0.003—0.005)	0.05	60	25	20000	0.004 (0.003—0.005)	0.05	80		
<b>0.5</b>	16	10000	0.006 (0.005—0.007)	0.1	60	31	20000	0.006 (0.005—0.007)	0.1	120		
<b>0.63</b>	20	10000	0.008 (0.006—0.01)	0.1	80	40	20000	0.008 (0.006—0.01)	0.1	160		
<b>0.8</b>	15	6000	0.015 (0.012—0.018)	0.2	90	50	20000	0.02 (0.015—0.025)	0.3	400		
<b>0.99</b>	19	6000	0.02 (0.015—0.025)	0.2	120	62	20000	0.04 (0.03—0.05)	0.3	800		

Обрабатываемый материал	Алюминиевые сплавы (Si<5%)						Жаропрочные сплавы Inconel718					
	Диам. сверла (мм)	Скорость резания (м/мин)	Частота вращения (мин <sup>-1</sup> )	Подача (мин. — макс.) (мм/об)	Шаг (мм)	Подача (мм/мин)	Скорость резания (м/мин)	Частота вращения (мин <sup>-1</sup> )	Подача (мин. — макс.) (мм/об)	Шаг (мм)	Подача (мм/мин)	
<b>0.1</b>	6	20000	0.002 (0.001—0.003)	0.05	40	2	7000	0.001 (0.0005—0.001)	0.02	7		
<b>0.12</b>	8	20000	0.003 (0.002—0.004)	0.05	60	3	7000	0.001 (0.0005—0.001)	0.02	7		
<b>0.16</b>	10	20000	0.004 (0.003—0.005)	0.05	80	4	7000	0.001 (0.0005—0.001)	0.02	7		
<b>0.2</b>	13	20000	0.006 (0.005—0.007)	0.1	120	3	5000	0.002 (0.001—0.002)	0.04	10		
<b>0.25</b>	16	20000	0.008 (0.006—0.01)	0.1	160	4	5000	0.002 (0.001—0.002)	0.04	10		
<b>0.32</b>	20	20000	0.01 (0.008—0.012)	0.3	200	4	4000	0.002 (0.001—0.002)	0.05	8		
<b>0.4</b>	25	20000	0.02 (0.015—0.025)	0.3	400	5	4000	0.002 (0.001—0.002)	0.05	8		
<b>0.5</b>	31	20000	0.03 (0.025—0.035)	0.5	600	5	3000	0.003 (0.001—0.003)	0.1	9		
<b>0.63</b>	40	20000	0.04 (0.035—0.045)	0.5	800	6	3000	0.004 (0.002—0.004)	0.1	12		
<b>0.8</b>	50	20000	0.05 (0.045—0.055)	0.8	1000	5	1800	0.006 (0.004—0.006)	0.2	10.8		
<b>0.99</b>	62	20000	0.06 (0.055—0.065)	0.8	1200	6	1800	0.01 (0.008—0.01)	0.2	18		

(Примечание)

- При сверлении до  $\phi 0.3$  мм рекомендуется использовать центровочное сверло.
- Измените режимы резания в зависимости от жесткости станка и заготовки.
- При глубине сверления свыше 5d снизьте установленную ранее глубину ступенчатого сверления.
- Для сверления при выше указанных режимах резания рекомендуется использовать СОЖ (разбавленную в пропорции 1:20).
- Материал, труднообрабатываемый с наружным охлаждением, маркируется знаком " - " в приведенной выше таблице. Рекомендуется использовать сверла типа MWS или VAPDSSUS.

СВЕРЛЕНИЕ

# MSP

## ЦЕНТРОВОЧНОЕ СВЕРЛО

ТВЕРДЫЙ  
СПЛАВ

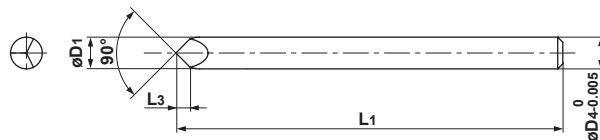

Обозначение	Материал	Наличие	Размеры (мм)				Диапазон диаметров (мм)
			D1	L3	L1	D4	
MSP0300SB	VP15TF	●	3	1.5	38	3	0.1—3.0

### РЕКОМЕНДУЕМЫЕ РЕЖИМЫ РЕЗАНИЯ

Диапазон диаметров отверстий (мм)	Частота вращения (мин <sup>-1</sup> )	Подача (мин. — макс.) (мм/об)	Подача (мм/мин)
0.1—3.0	10000	0.0005 (0.00025—0.001)	5

● : Есть на складе.

# СВЕРЛЕНИЕ (МОНОЛИТНЫЕ ТВЕРДОСПЛАВНЫЕ СВЕРЛА)

## MINI-MWS

- Микросверла с внутренним подводом СОЖ для стабильного сверления глубоких отверстий.
- Для высокоточного и эффективного сверления широкого спектра материалов: от углеродистой стали до труднообрабатываемых материалов.

Углеродистая сталь Легированная сталь	Закалённая сталь	Нержавеющая сталь	Чугун	Лёгкий сплав	Жаропрочные сплавы
○		○	○	○	○

	0.5 ≤ D1 < 1	1 ≤ D1 < 2.95
	+0.009 0	+0.014 0
	0 -0.006	0 -0.006

### Тип SB

(Для сверления направляющих отверстий)

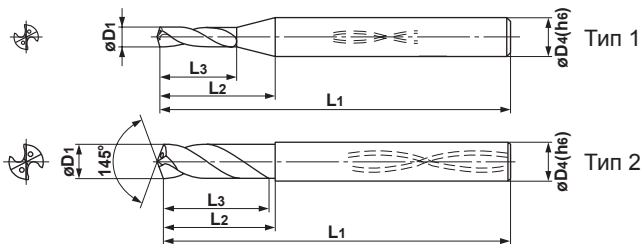

### Тип LB/XB



	0.5 ≤ D1 < 1	1 ≤ D1 < 2.95
	0 -0.009	0 -0.014
	0 -0.006	0 -0.006

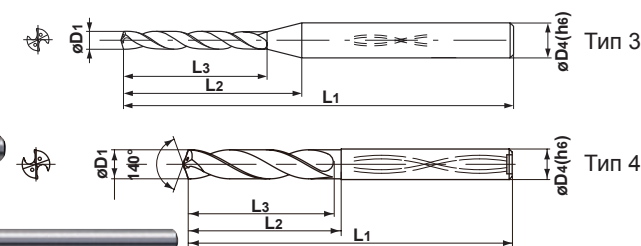

### Тип DB



(Примечание 1) Сверла MWS предназначены для использования с термоматрицами.

(Примечание 2) Угол при вершине сверла: Тип 1 140° для диаметра сверла φ0,50–2,00 и 145° для диаметра φ2,05–2,95.

Тип 3 135° для диаметра сверла φ 0,50–2,0 и 140° для диаметра φ2,05-2,95.

Диам. сверла D1 (мм)	Глубина сверления (l/d)	Охлаждение (Внут./Нар.)	Наличие VP15TF	Обозначение	Размеры (мм)				Тип
					L3	L2	L1	D4	
0.50	1	Внут.	●	MWS0050SB	2.5	7.2	47	3	1
	5	Внут.	★	0050LB	8	13	47	3	3
	12	Внут.	★	0050XB	16	21	47	3	3
0.51	1	Внут.	★	0051SB	2.6	7.2	47	3	1
	5	Внут.	★	0051LB	8	13	47	3	3
	12	Внут.	★	0051XB	16	21	47	3	3
0.52	1	Внут.	★	0052SB	2.6	7.2	47	3	1
	5	Внут.	★	0052LB	8	13	47	3	3
	12	Внут.	★	0052XB	16	21	47	3	3
0.53	1	Внут.	★	0053SB	2.6	7.2	47	3	1
	5	Внут.	★	0053LB	8	13	47	3	3
	12	Внут.	★	0053XB	16	21	47	3	3
0.54	1	Внут.	★	0054SB	2.6	7.2	47	3	1
	5	Внут.	★	0054LB	8	13	47	3	3
	12	Внут.	★	0054XB	16	21	47	3	3
0.55	1	Внут.	●	0055SB	2.6	7.2	47	3	1
	5	Внут.	★	0055LB	8	13	47	3	3
	12	Внут.	★	0055XB	16	21	47	3	3
0.56	1	Внут.	★	0056SB	2.9	7.5	47	3	1
	5	Внут.	★	0056LB	8	13	47	3	3
	12	Внут.	★	0056XB	16	21	47	3	3
0.57	1	Внут.	★	0057SB	2.9	7.4	47	3	1
	5	Внут.	★	0057LB	8	13	47	3	3
	12	Внут.	★	0057XB	16	21	47	3	3

Диам. сверла D1 (мм)	Глубина сверления (l/d)	Охлаждение (Внут./Нар.)	Наличие VP15TF	Обозначение	Размеры (мм)				Тип
					L3	L2	L1	D4	
0.58	1	Внут.	★	MWS0058SB	2.9	7.4	47	3	1
	5	Внут.	★	0058LB	8	13	47	3	3
	12	Внут.	★	0058XB	16	21	47	3	3
0.59	1	Внут.	★	0059SB	2.9	7.4	47	3	1
	5	Внут.	★	0059LB	8	12	47	3	3
	12	Внут.	★	0059XB	16	20	47	3	3
0.60	1	Внут.	●	0060SB	2.9	7.4	47	3	1
	5	Внут.	★	0060LB	8	12	47	3	3
	12	Внут.	★	0060XB	16	20	47	3	3
0.61	1	Внут.	★	0061SB	3.1	7.6	47	3	1
	5	Внут.	★	0061LB	8	12	47	3	3
	12	Внут.	★	0061XB	16	20	47	3	3
0.62	1	Внут.	★	0062SB	3.1	7.5	47	3	1
	5	Внут.	★	0062LB	8	12	47	3	3
	12	Внут.	★	0062XB	16	20	47	3	3
0.63	1	Внут.	★	0063SB	3.1	7.5	47	3	1
	5	Внут.	★	0063LB	8	12	47	3	3
	12	Внут.	★	0063XB	16	20	47	3	3
0.64	1	Внут.	★	0064SB	3.1	7.5	47	3	1
	5	Внут.	★	0064LB	8	12	47	3	3
	12	Внут.	★	0064XB	16	20	47	3	3
0.65	1	Внут.	●	0065SB	3.1	7.5	47	3	1
	5	Внут.	★	0065LB	8	12	47	3	3
	12	Внут.	★	0065XB	16	20	47	3	3

(Примечание) Пожалуйста, свяжитесь с нами если Вы не нашли нужную геометрию в данном каталоге (могут быть заказаны другие диаметры и длины).

● : Есть на складе. ★ : Со склада в Японии.

Диам. сверла D1 (мм)	Глубина сверления (l/d)	Охлаждение (Внут./Нар.)	Наличие VP15TF	Обозначение	Размеры (мм)				Тип
					L3	L2	L1	D4	
0.66	1	Внут.	★	MWS0066SB	3.4	7.8	47	3	1
	5	Внут.	★	0066LB	8	12	47	3	3
	12	Внут.	★	0066XB	16	20	47	3	3
0.67	1	Внут.	★	0067SB	3.4	7.7	47	3	1
	5	Внут.	★	0067LB	8	12	47	3	3
	12	Внут.	★	0067XB	16	20	47	3	3
0.68	1	Внут.	★	0068SB	3.4	7.7	47	3	1
	5	Внут.	★	0068LB	8	12	47	3	3
	12	Внут.	★	0068XB	16	20	47	3	3
0.69	1	Внут.	★	0069SB	3.4	7.7	47	3	1
	5	Внут.	★	0069LB	8	12	47	3	3
	12	Внут.	★	0069XB	16	20	47	3	3
0.70	1	Внут.	●	0070SB	3.4	7.7	47	3	1
	5	Внут.	★	0070LB	8	12	47	3	3
	12	Внут.	★	0070XB	16	20	47	3	3
0.71	1	Внут.	★	0071SB	3.6	7.9	50	3	1
	5	Внут.	★	0071LB	10	14	50	3	3
	12	Внут.	★	0071XB	20	24	50	3	3
0.72	1	Внут.	★	0072SB	3.6	7.9	50	3	1
	5	Внут.	★	0072LB	10	14	50	3	3
	12	Внут.	★	0072XB	20	24	50	3	3
0.73	1	Внут.	★	0073SB	3.6	7.8	50	3	1
	5	Внут.	★	0073LB	10	14	50	3	3
	12	Внут.	★	0073XB	20	24	50	3	3
0.74	1	Внут.	★	0074SB	3.6	7.8	50	3	1
	5	Внут.	★	0074LB	10	14	50	3	3
	12	Внут.	★	0074XB	20	24	50	3	3
0.75	1	Внут.	●	0075SB	3.6	7.8	50	3	1
	5	Внут.	★	0075LB	10	14	50	3	3
	12	Внут.	★	0075XB	20	24	50	3	3
0.76	1	Внут.	★	0076SB	3.9	8.1	50	3	1
	5	Внут.	★	0076LB	10	14	50	3	3
	12	Внут.	★	0076XB	20	24	50	3	3
0.77	1	Внут.	★	0077SB	3.9	8.1	50	3	1
	5	Внут.	★	0077LB	10	14	50	3	3
	12	Внут.	★	0077XB	20	24	50	3	3
0.78	1	Внут.	★	0078SB	3.9	8	50	3	1
	5	Внут.	★	0078LB	10	14	50	3	3
	12	Внут.	★	0078XB	20	24	50	3	3
0.79	1	Внут.	★	0079SB	3.9	8	50	3	1
	5	Внут.	★	0079LB	10	14	50	3	3
	12	Внут.	★	0079XB	20	24	50	3	3
0.80	1	Внут.	●	0080SB	3.9	8	50	3	1
	5	Внут.	★	0080LB	10	14	50	3	3
	12	Внут.	★	0080XB	20	24	50	3	3
0.81	1	Внут.	★	0081SB	4.1	8.2	50	3	1
	5	Внут.	★	0081LB	10	14	50	3	3
	12	Внут.	★	0081XB	20	24	50	3	3
0.82	1	Внут.	★	0082SB	4.1	8.2	50	3	1
	5	Внут.	★	0082LB	10	14	50	3	3
	12	Внут.	★	0082XB	20	24	50	3	3

Диам. сверла D1 (мм)	Глубина сверления (l/d)	Охлаждение (Внут./Нар.)	Наличие VP15TF	Обозначение	Размеры (мм)				Тип
					L3	L2	L1	D4	
0.83	1	Внут.	★	MWS0083SB	4.1	8.1	50	3	1
	5	Внут.	★	0083LB	10	14	50	3	3
	12	Внут.	★	0083XB	20	24	50	3	3
0.84	1	Внут.	★	0084SB	4.1	8.1	50	3	1
	5	Внут.	★	0084LB	10	14	50	3	3
	12	Внут.	★	0084XB	20	24	50	3	3
0.85	1	Внут.	●	0085SB	4.1	8.1	50	3	1
	5	Внут.	★	0085LB	10	14	50	3	3
	12	Внут.	★	0085XB	20	24	50	3	3
0.86	1	Внут.	★	0086SB	4.4	8.4	50	3	1
	5	Внут.	★	0086LB	10	14	50	3	3
	12	Внут.	★	0086XB	20	24	50	3	3
0.87	1	Внут.	★	0087SB	4.4	8.4	50	3	1
	5	Внут.	★	0087LB	10	14	50	3	3
	12	Внут.	★	0087XB	20	24	50	3	3
0.88	1	Внут.	★	0088SB	4.4	8.4	50	3	1
	5	Внут.	★	0088LB	10	14	50	3	3
	12	Внут.	★	0088XB	20	24	50	3	3
0.89	1	Внут.	★	0089SB	4.4	8.3	50	3	1
	5	Внут.	★	0089LB	10	14	50	3	3
	12	Внут.	★	0089XB	20	24	50	3	3
0.90	1	Внут.	●	0090SB	4.4	8.3	50	3	1
	5	Внут.	★	0090LB	10	14	50	3	3
	12	Внут.	★	0090XB	20	24	50	3	3
0.91	1	Внут.	★	0091SB	4.6	8.5	50	3	1
	5	Внут.	★	0091LB	10	14	50	3	3
	12	Внут.	★	0091XB	20	24	50	3	3
0.92	1	Внут.	★	0092SB	4.6	8.5	50	3	1
	5	Внут.	★	0092LB	10	14	50	3	3
	12	Внут.	★	0092XB	20	24	50	3	3
0.93	1	Внут.	★	0093SB	4.6	8.5	50	3	1
	5	Внут.	★	0093LB	10	14	50	3	3
	12	Внут.	★	0093XB	20	24	50	3	3
0.94	1	Внут.	★	0094SB	4.6	8.4	50	3	1
	5	Внут.	★	0094LB	10	14	50	3	3
	12	Внут.	★	0094XB	20	24	50	3	3
0.95	1	Внут.	●	0095SB	4.6	8.4	50	3	1
	5	Внут.	★	0095LB	10	14	50	3	3
	12	Внут.	★	0095XB	20	24	50	3	3
0.96	1	Внут.	★	0096SB	4.9	8.7	50	3	1
	5	Внут.	★	0096LB	10	14	50	3	3
	12	Внут.	★	0096XB	20	24	50	3	3
0.97	1	Внут.	★	0097SB	4.9	8.7	50	3	1
	5	Внут.	★	0097LB	10	14	50	3	3
	12	Внут.	★	0097XB	20	24	50	3	3
0.98	1	Внут.	★	0098SB	4.9	8.7	50	3	1
	5	Внут.	★	0098LB	10	14	50	3	3
	12	Внут.	★	0098XB	20	24	50	3	3
0.99	1	Внут.	★	0099SB	4.9	8.7	50	3	1
	5	Внут.	★	0099LB	10	14	50	3	3
	12	Внут.	★	0099XB	20	24	50	3	3

(Примечание) Пожалуйста, свяжитесь с нами если Вы не нашли нужную геометрию в данном каталоге (могут быть заказаны другие диаметры и длины).

# СВЕРЛЕНИЕ (МОНОЛИТНЫЕ ТВЕРДОСПЛАВНЫЕ СВЕРЛА)

## MINI-MWS

ТВЕРДЫЙ  
СПЛАВ

Диам. сверла D1 (мм)	Глубина сверления (l/d)	Охлаждение (Внут./Нар.)	Наличие VP15TF	Обозначение	Размеры (мм)				Тип
					L3	L2	L1	D4	
1.00	1	Внут.	●	MWS0100SB	5	8.7	55	3	1
	5	Внут.	●	0100LB	11	15	55	3	3
	12	Внут.	●	0100XB	23	27	55	3	3
	20	Внут.	●	0100X20DB	24	28	60	3	3
	25	Внут.	●	0100X25DB	28	32	66	3	3
	30	Внут.	●	0100X30DB	33	37	72	3	3
1.05	1	Внут.	●	0105SB	5.2	8.8	55	3	1
	20	Внут.	●	0105X20DB	24	28	60	3	3
	25	Внут.	●	0105X25DB	29	33	66	3	3
	30	Внут.	●	0105X30DB	35	38	72	3	3
1.10	1	Внут.	●	0110SB	5.4	8.9	55	3	1
	5	Внут.	●	0110LB	17	21	55	3	3
	12	Внут.	●	0110XB	23	27	55	3	3
	20	Внут.	●	0110X20DB	25	29	60	3	3
	25	Внут.	●	0110X25DB	31	34	66	3	3
	30	Внут.	●	0110X30DB	36	40	72	3	3
1.15	1	Внут.	●	0115SB	5.6	9.1	55	3	1
	20	Внут.	□	0115X20DB	26	30	60	3	3
	25	Внут.	□	0115X25DB	32	36	66	3	3
	30	Внут.	□	0115X30DB	38	41	72	3	3
1.20	1	Внут.	●	0120SB	6	9.4	55	3	1
	5	Внут.	●	0120LB	17	20	55	3	3
	12	Внут.	●	0120XB	23	26	55	3	3
	20	Внут.	●	0120X20DB	28	31	60	3	3
	25	Внут.	●	0120X25DB	34	37	66	3	3
	30	Внут.	●	0120X30DB	40	43	72	3	3
1.25	1	Внут.	●	0125SB	6.2	9.5	55	3	1
	20	Внут.	□	0125X20DB	29	32	68	3	3
	25	Внут.	□	0125X25DB	35	38	74	3	3
	30	Внут.	□	0125X30DB	41	45	82	3	3
1.30	1	Внут.	●	0130SB	6.4	9.6	55	3	1
	5	Внут.	●	0130LB	17	20	55	3	3
	12	Внут.	●	0130XB	23	26	55	3	3
	20	Внут.	●	0130X20DB	30	33	68	3	3
	25	Внут.	●	0130X25DB	36	40	74	3	3
	30	Внут.	●	0130X30DB	43	46	82	3	3
1.35	1	Внут.	●	0135SB	6.6	9.7	55	3	1
	20	Внут.	□	0135X20DB	31	34	68	3	3
	25	Внут.	□	0135X25DB	38	41	74	3	3
	30	Внут.	□	0135X30DB	45	48	82	3	3
1.40	1	Внут.	●	0140SB	7	10	55	3	1
	5	Внут.	●	0140LB	17	20	55	3	3
	12	Внут.	●	0140XB	23	26	55	3	3
	20	Внут.	●	0140X20DB	32	35	68	3	3
	25	Внут.	●	0140X25DB	39	42	74	3	3
	30	Внут.	●	0140X30DB	46	49	82	3	3
1.45	1	Внут.	●	0145SB	7.2	10.1	55	3	1
	20	Внут.	□	0145X20DB	33	36	68	3	3
	25	Внут.	□	0145X25DB	41	43	74	3	3
	30	Внут.	□	0145X30DB	48	51	82	3	3

Диам. сверла D1 (мм)	Глубина сверления (l/d)	Охлаждение (Внут./Нар.)	Наличие VP15TF	Обозначение	Размеры (мм)				Тип
					L3	L2	L1	D4	
1.50	1	Внут.	●	MWS0150SB	7.4	10.2	55	3	1
	5	Внут.	●	0150LB	17	20	55	3	3
	12	Внут.	●	0150XB	23	26	55	3	3
	20	Внут.	●	0150X20DB	35	37	68	3	3
	25	Внут.	●	0150X25DB	42	45	74	3	3
	30	Внут.	●	0150X30DB	50	52	82	3	3
1.55	1	Внут.	●	0155SB	7.6	10.3	68	3	1
	20	Внут.	□	0155X20DB	36	38	78	3	3
	25	Внут.	□	0155X25DB	43	46	86	3	3
	30	Внут.	□	0155X30DB	51	54	95	3	3
1.60	1	Внут.	●	0160SB	8	10.6	68	3	1
	5	Внут.	●	0160LB	22	25	68	3	3
	12	Внут.	●	0160XB	30	33	68	3	3
	20	Внут.	●	0160X20DB	37	39	78	3	3
	25	Внут.	●	0160X25DB	45	47	86	3	3
	30	Внут.	●	0160X30DB	53	55	95	3	3
1.65	1	Внут.	●	0165SB	8.2	10.7	68	3	1
	20	Внут.	□	0165X20DB	38	40	78	3	3
	25	Внут.	□	0165X25DB	46	49	86	3	3
	30	Внут.	□	0165X30DB	54	57	95	3	3
1.70	1	Внут.	●	0170SB	8.4	10.8	68	3	1
	5	Внут.	●	0170LB	22	24	68	3	3
	12	Внут.	●	0170XB	30	32	68	3	3
	20	Внут.	●	0170X20DB	39	42	78	3	3
	25	Внут.	●	0170X25DB	48	50	86	3	3
	30	Внут.	●	0170X30DB	56	59	95	3	3
1.75	1	Внут.	●	0175SB	8.6	10.9	68	3	1
	20	Внут.	□	0175X20DB	40	43	84	3	3
	25	Внут.	□	0175X25DB	49	51	94	3	3
	30	Внут.	□	0175X30DB	58	60	102	3	3
1.80	1	Внут.	●	0180SB	9	11.2	68	3	1
	5	Внут.	●	0180LB	22	24	68	3	3
	12	Внут.	●	0180XB	30	32	68	3	3
	20	Внут.	●	0180X20DB	41	44	84	3	3
	25	Внут.	●	0180X25DB	50	53	94	3	3
	30	Внут.	●	0180X30DB	59	62	102	3	3
1.85	1	Внут.	●	0185SB	9.2	11.3	68	3	1
	20	Внут.	□	0185X20DB	43	45	84	3	3
	25	Внут.	□	0185X25DB	52	54	94	3	3
	30	Внут.	□	0185X30DB	61	63	102	3	3
1.90	1	Внут.	●	0190SB	9.4	11.5	68	3	1
	5	Внут.	●	0190LB	22	24	68	3	3
	12	Внут.	●	0190XB	30	32	68	3	3
	20	Внут.	●	0190X20DB	44	46	84	3	3
	25	Внут.	●	0190X25DB	53	55	94	3	3
	30	Внут.	●	0190X30DB	63	65	102	3	3
1.95	1	Внут.	●	0195SB	9.6	11.6	68	3	1
	20	Внут.	□	0195X20DB	45	47	84	3	3
	25	Внут.	□	0195X25DB	55	57	94	3	3
	30	Внут.	□	0195X30DB	64	66	102	3	3

● : Есть на складе. □ : Нет на складе, выпускается исключительно под заказ.

Диам. сверла D1 (мм)	Глубина сверления (l/d)	Охлаждение (Внут./Нар.)	Наличие VP15TF	Обозначение	Размеры (мм)				Тип
					L3	L2	L1	D4	
2.00	1	Внут.	●	MWS0200SB	10	11.9	68	3	1
	5	Внут.	●	0200LB	22	24	68	3	3
	12	Внут.	●	0200XB	30	32	68	3	3
	20	Внут.	●	0200X20DB	46	48	84	3	3
	25	Внут.	●	0200X25DB	56	58	94	3	3
	30	Внут.	●	0200X30DB	66	68	102	3	3
2.05	1	Внут.	●	0205SB	10.2	12	74	3	1
	20	Внут.	●	0205X20DB	47	49	94	3	3
	25	Внут.	●	0205X25DB	57	59	107	3	3
	30	Внут.	●	0205X30DB	68	69	118	3	3
2.10	1	Внут.	●	0210SB	10.4	12.1	74	3	1
	5	Внут.	●	0210LB	28	30	74	3	3
	12	Внут.	●	0210XB	38	40	74	3	3
	20	Внут.	●	0210X20DB	48	50	94	3	3
	25	Внут.	●	0210X25DB	59	60	107	3	3
	30	Внут.	●	0210X30DB	69	71	118	3	3
2.15	1	Внут.	●	0215SB	10.6	12.2	74	3	1
	20	Внут.	□	0215X20DB	49	51	94	3	3
	25	Внут.	□	0215X25DB	60	62	107	3	3
	30	Внут.	□	0215X30DB	71	73	118	3	3
2.20	1	Внут.	●	0220SB	11	12.5	74	3	1
	5	Внут.	●	0220LB	28	29	74	3	3
	12	Внут.	●	0220XB	38	39	74	3	3
	20	Внут.	●	0220X20DB	51	52	94	3	3
	25	Внут.	●	0220X25DB	62	63	107	3	3
	30	Внут.	●	0220X30DB	73	74	118	3	3
2.25	1	Внут.	●	0225SB	11.2	12.6	74	3	1
	20	Внут.	□	0225X20DB	52	53	94	3	3
	25	Внут.	□	0225X25DB	63	64	107	3	3
	30	Внут.	□	0225X30DB	74	76	118	3	3
2.30	1	Внут.	●	0230SB	11.4	12.7	74	3	1
	5	Внут.	●	0230LB	28	29	74	3	3
	12	Внут.	●	0230XB	38	39	74	3	3
	20	Внут.	●	0230X20DB	53	54	94	3	3
	25	Внут.	●	0230X25DB	64	66	107	3	3
	30	Внут.	●	0230X30DB	76	77	118	3	3
2.35	1	Внут.	●	0235SB	11.6	12.8	74	3	1
	20	Внут.	□	0235X20DB	54	55	94	3	3
	25	Внут.	□	0235X25DB	66	67	107	3	3
	30	Внут.	□	0235X30DB	78	79	118	3	3
2.40	1	Внут.	●	0240SB	12	13.1	74	3	1
	5	Внут.	●	0240LB	28	29	74	3	3
	12	Внут.	●	0240XB	38	39	74	3	3
	20	Внут.	●	0240X20DB	55	56	94	3	3
	25	Внут.	●	0240X25DB	67	68	107	3	3
	30	Внут.	●	0240X30DB	79	80	118	3	3
2.45	1	Внут.	●	0245SB	12.2	13.2	74	3	1
	20	Внут.	□	0245X20DB	56	57	94	3	3
	25	Внут.	□	0245X25DB	69	70	107	3	3
	30	Внут.	□	0245X30DB	81	82	118	3	3

Диам. сверла D1 (мм)	Глубина сверления (l/d)	Охлаждение (Внут./Нар.)	Наличие VP15TF	Обозначение	Размеры (мм)				Тип
					L3	L2	L1	D4	
2.50	1	Внут.	●	MWS0250SB	12.4	13.3	74	3	1
	5	Внут.	●	0250LB	28	29	74	3	3
	12	Внут.	●	0250XB	38	39	74	3	3
	20	Внут.	●	0250X20DB	58	59	94	3	3
	25	Внут.	●	0250X25DB	70	71	107	3	3
	30	Внут.	●	0250X30DB	83	84	118	3	3
2.55	1	Внут.	●	0255SB	12.6	12.6	81	3	2
	20	Внут.	●	0255X20DB	59	59	103	3	4
	25	Внут.	●	0255X25DB	71	71	117	3	4
	30	Внут.	●	0255X30DB	84	84	132	3	4
2.60	1	Внут.	●	0260SB	13	13	81	3	2
	5	Внут.	●	0260LB	33	33	81	3	4
	12	Внут.	●	0260XB	45	45	81	3	4
	20	Внут.	●	0260X20DB	60	60	103	3	4
	25	Внут.	●	0260X25DB	73	73	117	3	4
	30	Внут.	●	0260X30DB	86	86	132	3	4
2.65	1	Внут.	●	0265SB	13.2	13.2	81	3	2
	20	Внут.	□	0265X20DB	61	61	103	3	4
	25	Внут.	□	0265X25DB	74	74	117	3	4
	30	Внут.	□	0265X30DB	87	87	132	3	4
2.70	1	Внут.	●	0270SB	13.4	13.4	81	3	2
	5	Внут.	●	0270LB	33	33	81	3	4
	12	Внут.	●	0270XB	45	45	81	3	4
	20	Внут.	●	0270X20DB	62	62	103	3	4
	25	Внут.	●	0270X25DB	76	76	117	3	4
	30	Внут.	●	0270X30DB	89	89	132	3	4
2.75	1	Внут.	●	0275SB	13.6	13.6	81	3	2
	20	Внут.	□	0275X20DB	63	63	103	3	4
	25	Внут.	□	0275X25DB	77	77	117	3	4
	30	Внут.	□	0275X30DB	91	91	132	3	4
2.80	1	Внут.	●	0280SB	14	14	81	3	2
	5	Внут.	●	0280LB	33	33	81	3	4
	12	Внут.	●	0280XB	45	45	81	3	4
	20	Внут.	●	0280X20DB	64	64	103	3	4
	25	Внут.	●	0280X25DB	78	78	117	3	4
	30	Внут.	●	0280X30DB	92	92	132	3	4
2.85	1	Внут.	●	0285SB	14.2	14.2	81	3	2
	20	Внут.	□	0285X20DB	66	66	103	3	4
	25	Внут.	□	0285X25DB	80	80	117	3	4
	30	Внут.	□	0285X30DB	94	94	132	3	4
2.90	1	Внут.	●	0290SB	14.4	14.4	81	3	2
	5	Внут.	●	0290LB	33	33	81	3	4
	12	Внут.	●	0290XB	45	45	81	3	4
	20	Внут.	●	0290X20DB	67	67	103	3	4
	25	Внут.	●	0290X25DB	81	81	117	3	4
	30	Внут.	●	0290X30DB	96	96	132	3	4
2.95	1	Внут.	●	0295SB	14.6	14.6	81	3	2
	20	Внут.	□	0295X20DB	68	68	103	3	4
	25	Внут.	□	0295X25DB	83	83	117	3	4
	30	Внут.	□	0295X30DB	97	97	132	3	4

(Примечание) Пожалуйста, свяжитесь с нами если Вы не нашли нужную геометрию в данном каталоге (могут быть заказаны другие диаметры и длины).

РЕЖИМЫ РЕЗАНИЯ > L016  
ИНСТРУКЦИЯ ПО ЭКСПЛУАТАЦИИ > L020  
ТЕХНИЧЕСКИЕ ДАННЫЕ > N001

### РЕКОМЕНДУЕМЫЕ РЕЖИМЫ РЕЗАНИЯ

#### Тип SB/LB/XB/DB (l/d<10)

Обрабатываемый материал	Малоуглеродистая сталь ( $\leq 180\text{HB}$ )					Углеродистая сталь Легированная сталь (180—280HB)				
	Ck10					Ck45, 42CrMo4				
Диам. сверла (мм)	Скорость резания (м/мин)	Частота вращения ( $\text{мин}^{-1}$ )	Подача (мин. — макс.) (мм/об)		Подача (мм/мин)	Скорость резания (м/мин)	Частота вращения ( $\text{мин}^{-1}$ )	Подача (мин. — макс.) (мм/об)		Подача (мм/мин)
<b>0.5</b>	40	25400	0.01 (0.005—0.015)		250	40	25400	0.01 (0.005—0.015)		250
<b>1.0</b>	50	15900	0.035 (0.020—0.050)		555	50	15900	0.035 (0.020—0.050)		555
<b>1.5</b>	50	10600	0.055 (0.035—0.080)		580	50	10600	0.055 (0.035—0.080)		580
<b>2.0</b>	50	7900	0.07 (0.040—0.100)		550	50	7900	0.07 (0.040—0.100)		550
<b>2.5</b>	60	7600	0.085 (0.050—0.125)		645	60	7600	0.085 (0.050—0.125)		645
<b>2.95</b>	90	9500	0.10 (0.060—0.130)		950	80	8400	0.10 (0.060—0.130)		840

Обрабатываемый материал	Углеродистая сталь Легированная сталь (280—350HB)					Аустенитная нержавеющая сталь ( $\leq 200\text{HB}$ )				
	36CrNiMo4					X5CrNi1810, X5CrNiMo17-12-2				
Диам. сверла (мм)	Скорость резания (м/мин)	Частота вращения ( $\text{мин}^{-1}$ )	Подача (мин. — макс.) (мм/об)		Подача (мм/мин)	Скорость резания (м/мин)	Частота вращения ( $\text{мин}^{-1}$ )	Подача (мин. — макс.) (мм/об)		Подача (мм/мин)
<b>0.5</b>	30	19000	0.01 (0.005—0.015)		190	20	12700	0.008 (0.005—0.010)		100
<b>1.0</b>	40	12700	0.035 (0.020—0.050)		440	30	9500	0.03 (0.020—0.044)		285
<b>1.5</b>	40	8400	0.055 (0.035—0.080)		460	30	6300	0.05 (0.035—0.070)		315
<b>2.0</b>	40	6300	0.07 (0.040—0.100)		440	30	4700	0.06 (0.040—0.080)		280
<b>2.5</b>	50	6300	0.085 (0.050—0.125)		535	40	5000	0.075 (0.050—0.100)		375
<b>2.95</b>	70	7400	0.10 (0.060—0.130)		740	40	4200	0.08 (0.060—0.100)		335

Обрабатываемый материал	Серый чугун ( $\leq 350\text{MPa}$ )				Ковкий чугун ( $\leq 450\text{MPa}$ )			
	GG30				GGG45			
Диам. сверла (мм)	Скорость резания (м/мин)	Частота вращения ( $\text{мин}^{-1}$ )	Подача (мин. — макс.) (мм/об)	Подача (мм/мин)	Скорость резания (м/мин)	Частота вращения ( $\text{мин}^{-1}$ )	Подача (мин. — макс.) (мм/об)	Подача (мм/мин)
<b>0.5</b>	40	25400	0.01 (0.005—0.015)	250	30	19000	0.01 (0.005—0.015)	190
<b>1.0</b>	50	15900	0.035 (0.020—0.050)	555	40	12700	0.035 (0.020—0.050)	440
<b>1.5</b>	50	10600	0.055 (0.035—0.080)	580	40	8400	0.055 (0.035—0.080)	460
<b>2.0</b>	50	7900	0.07 (0.040—0.100)	550	40	6300	0.07 (0.040—0.100)	440
<b>2.5</b>	60	7600	0.085 (0.050—0.125)	645	50	6300	0.085 (0.050—0.125)	535
<b>2.95</b>	90	9500	0.10 (0.060—0.130)	950	65	6800	0.10 (0.060—0.130)	680

Обрабатываемый материал	Алюминиевые сплавы ( $\text{Si} < 5\%$ )				Жаропрочные сплавы			
					Inconel718			
Диам. сверла (мм)	Скорость резания (м/мин)	Частота вращения ( $\text{мин}^{-1}$ )	Подача (мин. — макс.) (мм/об)	Подача (мм/мин)	Скорость резания (м/мин)	Частота вращения ( $\text{мин}^{-1}$ )	Подача (мин. — макс.) (мм/об)	Подача (мм/мин)
<b>0.5</b>	40	25400	0.014 (0.008—0.020)	355	10	6300	0.006 (0.004—0.008)	35
<b>1.0</b>	60	19000	0.05 (0.030—0.075)	950	10	3100	0.02 (0.016—0.027)	60
<b>1.5</b>	80	16900	0.085 (0.053—0.120)	1435	10	2100	0.03 (0.025—0.040)	60
<b>2.0</b>	90	14300	0.105 (0.060—0.150)	1500	15	2300	0.04 (0.032—0.050)	90
<b>2.5</b>	100	12700	0.135 (0.075—0.200)	1710	15	1900	0.05 (0.040—0.060)	95
<b>2.95</b>	120	12700	0.23 (0.100—0.350)	2920	20	2100	0.07 (0.050—0.090)	145

### РЕКОМЕНДУЕМЫЕ РЕЖИМЫ РЕЗАНИЯ

#### ■ Тип DB ( $l/d \geq 10$ )

Обрабатываемый материал	Малоуглеродистая сталь ( $\leq 180\text{HB}$ )					Углеродистая сталь Легированная сталь (180—280HB)				
	Ck10					Ck45, 42CrMo4				
Диам. сверла (мм)	Скорость резания (м/мин)	Частота вращения (мин <sup>-1</sup> )	Подача (мин. — макс.) (мм/об)		Подача (мм/мин)	Скорость резания (м/мин)	Частота вращения (мин <sup>-1</sup> )	Подача (мин. — макс.) (мм/об)		Подача (мм/мин)
1.0	50	15900	0.02 (0.010—0.030)		320	40	12700	0.02 (0.010—0.030)		255
1.5	50	10600	0.055 (0.032—0.080)		580	40	8400	0.055 (0.032—0.080)		460
2.0	60	9500	0.07 (0.040—0.100)		665	50	7900	0.07 (0.040—0.100)		550
2.5	60	7600	0.09 (0.063—0.125)		685	50	6300	0.09 (0.055—0.125)		565
2.95	90	9500	0.10 (0.060—0.130)		950	80	8400	0.10 (0.060—0.130)		840

Обрабатываемый материал	Углеродистая сталь Легированная сталь (280—350HB)					Аустенитная нержавеющая сталь ( $\leq 200\text{HB}$ )				
	36CrNiMo4					X5CrNi1810, X5CrNiMo17-12-2				
Диам. сверла (мм)	Скорость резания (м/мин)	Частота вращения (мин <sup>-1</sup> )	Подача (мин. — макс.) (мм/об)		Подача (мм/мин)	Скорость резания (м/мин)	Частота вращения (мин <sup>-1</sup> )	Подача (мин. — макс.) (мм/об)		Подача (мм/мин)
1.0	30	9500	0.015 (0.009—0.028)		140	30	9500	0.015 (0.009—0.028)		140
1.5	30	6300	0.05 (0.027—0.076)		315	30	6300	0.045 (0.025—0.065)		280
2.0	50	7900	0.065 (0.034—0.095)		515	30	4700	0.055 (0.030—0.080)		255
2.5	50	6300	0.08 (0.045—0.120)		505	40	5000	0.06 (0.035—0.085)		300
2.95	70	7400	0.09 (0.050—0.120)		665	40	4200	0.07 (0.050—0.090)		290

Обрабатываемый материал	Серый чугун ( $\leq 350\text{MPa}$ )					Ковкий чугун ( $\leq 450\text{MPa}$ )				
	GG30					GGG45				
Диам. сверла (мм)	Скорость резания (м/мин)	Частота вращения ( $\text{мин}^{-1}$ )	Подача (мин. — макс.) (мм/об)		Подача (мм/мин)	Скорость резания (м/мин)	Частота вращения ( $\text{мин}^{-1}$ )	Подача (мин. — макс.) (мм/об)		Подача (мм/мин)
<b>1.0</b>	40	12700	0.02 (0.010—0.030)		255	30	9500	0.015 (0.009—0.028)		140
<b>1.5</b>	40	8400	0.055 (0.032—0.080)		460	30	6300	0.05 (0.027—0.076)		315
<b>2.0</b>	50	7900	0.07 (0.040—0.100)		550	50	7900	0.065 (0.034—0.095)		515
<b>2.5</b>	50	6300	0.09 (0.055—0.125)		565	50	6300	0.08 (0.045—0.120)		505
<b>2.95</b>	90	9500	0.10 (0.060—0.130)		950	50	5300	0.09 (0.050—0.120)		475

Обрабатываемый материал	Алюминиевые сплавы (Si<5%)					Жаропрочные сплавы				
	Inconel718									
Диам. сверла (мм)	Скорость резания (м/мин)	Частота вращения ( $\text{мин}^{-1}$ )	Подача (мин. — макс.) (мм/об)		Подача (мм/мин)	Скорость резания (м/мин)	Частота вращения ( $\text{мин}^{-1}$ )	Подача (мин. — макс.) (мм/об)		Подача (мм/мин)
<b>1.0</b>	50	15900	0.05 (0.030—0.075)		795	10	3100	0.02 (0.016—0.027)		60
<b>1.5</b>	70	14800	0.085 (0.053—0.120)		1255	10	2100	0.03 (0.025—0.040)		60
<b>2.0</b>	80	12700	0.105 (0.060—0.150)		1335	15	2300	0.04 (0.032—0.050)		90
<b>2.5</b>	90	11400	0.135 (0.075—0.200)		1540	15	1900	0.05 (0.040—0.060)		95
<b>2.95</b>	100	10600	0.23 (0.100—0.350)		2435	20	2100	0.07 (0.050—0.090)		145

### ИНСТРУКЦИЯ ПО ЭКСПЛУАТАЦИИ

#### Крепление сверла

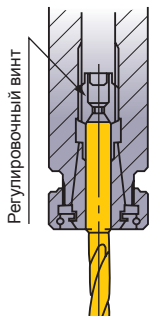

Цанговый патрон с упорным подшипником надежно держит сверло.

#### Длина сверла

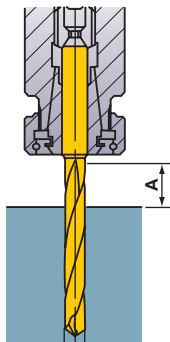

$$A \geq D1 \times 2.0$$

#### Установка сверла

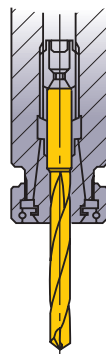

Не прижимать по режущей кромке.

#### Установка сверла

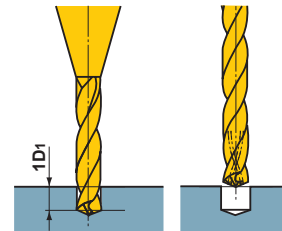

- ① Для пилотного отверстия используйте сверла короткой серии (SB).
- ② Применяя сверло с отверстием для подачи СОЖ, используйте предварительно обработанное отверстие как направляющее. В зависимости от режимов обработки рекомендуется подача с периодическим выводом сверла из отверстия.

#### Тип охлаждения через сквозные отверстия

Тип охлаждения через шпиндель

Тип охлаждения на вращающийся шпиндель станка

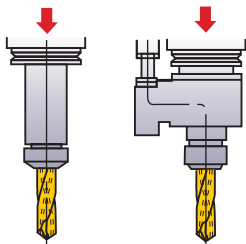

Рекомендуемое давление охлаждающей среды не менее 1.5 Мпа и не более 3 Мпа.

#### Тонкая заготовка

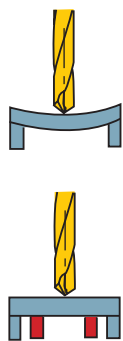

Если наблюдается отгиб.

Необходима опора для заготовки.

#### Рекомендации по использованию СОЖ

- 1) Мелкая металлическая стружка забивается в отверстие для подачи СОЖ в сверлах малого диаметра. Для предотвращения этого процесса обязательно используйте мелкий сетчатый фильтр.
- 2) Частицы грязи и пыли прилипают к маслу в составе СОЖ и препятствуют эффективной подаче СОЖ. Рекомендуется регулярно менять СОЖ.

### ПРИМЕЧАНИЯ К ЭКСПЛУАТАЦИИ

- Используйте мелкий сетчатый фильтр (меш  $\leq 3\mu m$ ) для СОЖ, для того чтобы предотвратить образование пробки в отверстии
- При сверлении глубоких отверстий сверлом MWS-DB рекомендуется сначала просверлить направляющее отверстие.  
(В противном случае центробежные силы могут привести к поломке сверла.)

## РУКОВОДСТВО ПО ИСПОЛЬЗОВАНИЮ MWS-DB

### СВЕРЛЕНИЕ НА ПЛОСКИХ ПОВЕРХНОСТЯХ ● Сделать глухое отверстие

#### 1. Выполнить направляющее отверстие

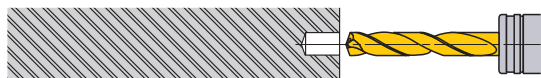

- ① Используйте сверло с большим двойным углом в плане, большим чем у длинных серий. Рекомендуется тип MWS-SB.
- ② Для обеспечения безупречного выполнения сверления, точно выполняйте направляющее отверстие.
- ③ Глубина сверления: около 1XD диаметра.  
(Выберите глубину направляющего отверстия, соответствующую длине длинного сверла.)

#### 2. Предварительная обработка при помощи длинного сверла.

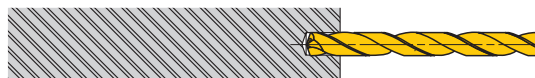

- ① Вход в направляющее отверстие с малой частотой вращения.  
(Скорость резания 20—30 м/мин, подача 0.2—0.3 мм/об)
- ② Остановить сверло для глубоких отверстий 0.5—1.0 мм до достижения дна направляющего отверстия.

#### 3. сверление глубокого отверстия

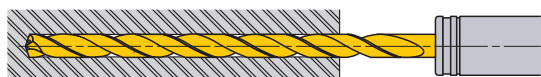

- ① Увеличьте частоту вращения и подачу за цикл и просверлите до желаемой глубины.

#### 4. Выведите сверло

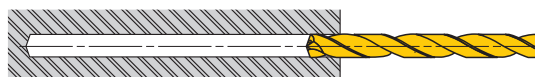

- ① После просверливания, примерно на 1—2 мм до конца отверстия, уменьшить скорость резания (скорость резания 20—30 м/мин.)
- ② Выньте сверло примерно до глубины направляющего отверстия ( $V_f=3000\text{мм/мин.}$ )
- ③ Выведите сверло из направляющего отверстия с уменьшенной частотой вращения ( $n=300, V_f=3000\text{мм/мин}$ )

### СВЕРЛЕНИЕ НА НАКЛОННЫХ ПОВЕРХНОСТЯХ ● Отверстия на изогнутых заготовках

#### 1. Плоское фрезерование



- ① Фрезеруйте плоскую поверхность в заготовке и установите фрезу с тем же диаметром, что и диаметр желаемого отверстия.

#### 2. Выполнить направляющее отверстие



- ① Используйте сверло с большим двойным углом в плане, большим чем у длинных серий. Рекомендуется тип MWS-SB.
- ② Для обеспечения безупречного выполнения сверления, точно выполняйте направляющее отверстие.
- ③ Глубина сверления: около 1XD диаметра.

#### 3. Предварительная обработка при помощи длинного сверла.



- ① Вход в направляющее отверстие с малой частотой вращения.  
(Скорость резания 20—30 м/мин, подача 0.2—0.3 мм/об)
- ② Остановить сверло для глубоких отверстий 1—3 мм до достижения дна направляющего отверстия.

#### 4. сверление глубокого отверстия

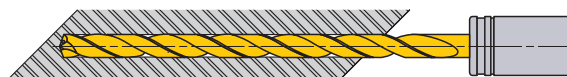

- ① Увеличьте частоту вращения и подачу за цикл и просверлите до желаемой глубины.

#### 5. Проходные отверстия

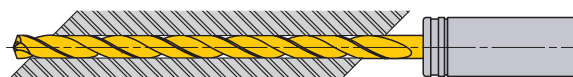

- ① При выходе из заготовки режущая кромка сверла может обломиться.
- ② Подача должна соответствовать половине нормальной подачи.

#### 6. Выведите сверло

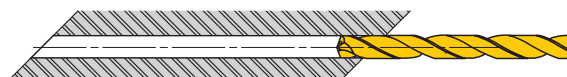

- ① Обработайте отверстие со скоростью резания 20—30 м/мин и подачей 0.2—0.3 мм/об.
- ② Поднимите сверло из направляющего отверстия до глубины начальной точки с подачей 3000 мм/мин.

# СВЕРЛЕНИЕ (МОНОЛИТНЫЕ ТВЕРДОСПЛАВНЫЕ СВЕРЛА)

## MWE

- Применяются для высокоэффективного и высокоточного сверления широкого спектра материалов, от сталей до труднообрабатываемых материалов.
- Применяются для низко- и высокоскоростной обработки. Возможно использование для обработки быстрорежущих сталей.



Углеродистая сталь Легированная сталь	Закалённая сталь	Нержавеющая сталь	Чугун	Лёгкий сплав	Жаропрочные сплавы
○	○	○	○	○	○

	D1=3	3<D1≤6	6<D1≤10	10<D1≤18	18<D1≤25
<b>h8</b>	0 -0.014	0 -0.018	0 -0.022	0 -0.027	0 -0.033
<b>h5</b>	0 -0.014	0 -0.018	0 -0.022	0 -0.027	0 -0.033
<b>h6</b>	0 -0.006	0 -0.008	0 -0.009	0 -0.011	0 -0.013

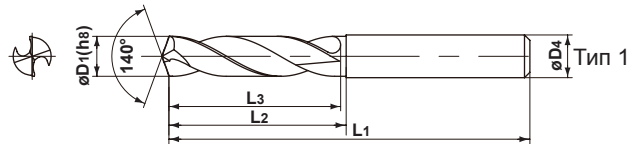

Диам. сверла D1 (мм)	Глубина сверления (l/d)	Охлаждение (Внут./Нар.)	Наличие VP15TF	Обозначение	Размеры (мм)				Тип
					L3	L2	L1	D4	
3.0	2	Нар.	●	MWE0300SA	16	16	55	3	1
	3	Нар.	●	MWE0300MA	21	21	60	3	1
3.1	2	Нар.	●	MWE0310SA	18	18	55	3.1	1
	3	Нар.	●	MWE0310MA	24	24	60	3.1	1
3.2	2	Нар.	●	MWE0320SA	18	18	55	3.2	1
	3	Нар.	●	MWE0320MA	24	24	60	3.2	1
3.3	2	Нар.	●	MWE0330SA	18	18	55	3.3	1
	3	Нар.	●	MWE0330MA	24	24	60	3.3	1
3.4	2	Нар.	●	MWE0340SA	20	20	55	3.4	1
	3	Нар.	●	MWE0340MA	24	24	60	3.4	1
3.5	2	Нар.	●	MWE0350SA	20	20	55	3.5	1
	3	Нар.	●	MWE0350MA	24	24	60	3.5	1
3.6	2	Нар.	★	MWE0360SA	20	20	55	3.6	1
	3	Нар.	●	MWE0360MA	27	27	60	3.6	1
3.7	2	Нар.	★	MWE0370SA	20	20	55	3.7	1
	3	Нар.	★	MWE0370MA	27	27	60	3.7	1
3.8	2	Нар.	●	MWE0380SA	22	22	55	3.8	1
	3	Нар.	●	MWE0380MA	27	27	60	3.8	1
3.9	2	Нар.	●	MWE0390SA	22	22	55	3.9	1
	3	Нар.	★	MWE0390MA	27	27	60	3.9	1
4.0	2	Нар.	●	MWE0400SA	22	22	55	4	1
	3	Нар.	●	MWE0400MA	27	27	60	4	1
4.1	2	Нар.	●	MWE0410SA	22	22	55	4.1	1
	3	Нар.	★	MWE0410MA	29	29	63	4.1	1
4.2	2	Нар.	●	MWE0420SA	22	22	55	4.2	1
	3	Нар.	●	MWE0420MA	29	29	63	4.2	1
4.3	2	Нар.	●	MWE0430SA	24	24	58	4.3	1
	3	Нар.	●	MWE0430MA	29	29	63	4.3	1
4.4	2	Нар.	★	MWE0440SA	24	24	58	4.4	1
	3	Нар.	●	MWE0440MA	29	29	63	4.4	1
4.5	2	Нар.	★	MWE0450SA	24	24	58	4.5	1
	3	Нар.	●	MWE0450MA	29	29	63	4.5	1
4.6	2	Нар.	★	MWE0460SA	24	24	58	4.6	1
	3	Нар.	●	MWE0460MA	32	32	68	4.6	1
4.7	2	Нар.	★	MWE0470SA	24	24	58	4.7	1
	3	Нар.	★	MWE0470MA	32	32	68	4.7	1

Диам. сверла D1 (мм)	Глубина сверления (l/d)	Охлаждение (Внут./Нар.)	Наличие VP15TF	Обозначение	Размеры (мм)				Тип
					L3	L2	L1	D4	
4.8	2	Нар.	★	MWE0480SA	26	26	62	4.8	1
	3	Нар.	●	MWE0480MA	32	32	68	4.8	1
4.9	2	Нар.	★	MWE0490SA	26	26	62	4.9	1
	3	Нар.	●	MWE0490MA	32	32	68	4.9	1
5.0	2	Нар.	●	MWE0500SA	26	26	62	5	1
	3	Нар.	●	MWE0500MA	32	32	68	5	1
5.1	2	Нар.	●	MWE0510SA	26	26	62	5.1	1
	3	Нар.	●	MWE0510MA	34	34	72	5.1	1
5.2	2	Нар.	●	MWE0520SA	26	26	62	5.2	1
	3	Нар.	●	MWE0520MA	34	34	72	5.2	1
5.3	2	Нар.	★	MWE0530SA	26	26	62	5.3	1
	3	Нар.	★	MWE0530MA	34	34	72	5.3	1
5.4	2	Нар.	★	MWE0540SA	28	28	66	5.4	1
	3	Нар.	●	MWE0540MA	34	34	72	5.4	1
5.5	2	Нар.	●	MWE0550SA	28	28	66	5.5	1
	3	Нар.	●	MWE0550MA	34	34	72	5.5	1
5.6	2	Нар.	★	MWE0560SA	28	28	66	5.6	1
	3	Нар.	●	MWE0560MA	36	36	74	5.6	1
5.7	2	Нар.	★	MWE0570SA	28	28	66	5.7	1
	3	Нар.	★	MWE0570MA	36	36	74	5.7	1
5.8	2	Нар.	★	MWE0580SA	28	28	66	5.8	1
	3	Нар.	●	MWE0580MA	36	36	74	5.8	1
5.9	2	Нар.	★	MWE0590SA	28	28	66	5.9	1
	3	Нар.	★	MWE0590MA	36	36	74	5.9	1
6.0	2	Нар.	●	MWE0600SA	28	28	66	6	1
	3	Нар.	●	MWE0600MA	41	41	81	6	1
6.1	2	Нар.	★	MWE0610SA	31	31	70	6.1	1
	3	Нар.	●	MWE0610MA	41	41	81	6.1	1
6.2	2	Нар.	★	MWE0620SA	31	31	70	6.2	1
	3	Нар.	●	MWE0620MA	41	41	81	6.2	1
6.3	2	Нар.	★	MWE0630SA	31	31	70	6.3	1
	3	Нар.	●	MWE0630MA	41	41	71	6.3	1
6.4	2	Нар.	★	MWE0640SA	31	31	70	6.4	1
	3	Нар.	★	MWE0640MA	41	41	81	6.4	1
6.5	2	Нар.	●	MWE0650SA	31	31	70	6.5	1
	3	Нар.	●	MWE0650MA	41	41	81	6.5	1

(Примечание) Пожалуйста, свяжитесь с нами если Вы не нашли нужную геометрию в данном каталоге (могут быть заказаны другие диаметры и длины).

● : Есть на складе. ★ : Со склада в Японии.

Диам. сверла D1 (мм)	Глубина сверления (l/d)	Охлаждение (Внут./Нар.)	Наличие VP15TF	Обозначение	Размеры (мм)				Тип
					L3	L2	L1	D4	
6.6	2	Нар.	★	MWE0660SA	31	31	70	6.6	1
	3	Нар.	★	MWE0660MA	43	43	83	6.6	1
6.7	2	Нар.	★	MWE0670SA	31	31	70	6.7	1
	3	Нар.	★	MWE0670MA	43	43	83	6.7	1
6.8	2	Нар.	●	MWE0680SA	34	34	74	6.8	1
	3	Нар.	●	MWE0680MA	43	43	83	6.8	1
6.9	2	Нар.	★	MWE0690SA	34	34	74	6.9	1
	3	Нар.	●	MWE0690MA	43	43	83	6.9	1
7.0	2	Нар.	●	MWE0700SA	34	34	74	7	1
	3	Нар.	●	MWE0700MA	43	43	83	7	1
7.1	2	Нар.	★	MWE0710SA	34	34	74	7.1	1
	3	Нар.	●	MWE0710MA	45	45	87	7.1	1
7.2	2	Нар.	★	MWE0720SA	34	34	74	7.2	1
	3	Нар.	★	MWE0720MA	45	45	87	7.2	1
7.3	2	Нар.	★	MWE0730SA	34	34	74	7.3	1
	3	Нар.	●	MWE0730MA	45	45	87	7.3	1
7.4	2	Нар.	★	MWE0740SA	34	34	74	7.4	1
	3	Нар.	●	MWE0740MA	45	45	87	7.4	1
7.5	2	Нар.	★	MWE0750SA	34	34	74	7.5	1
	3	Нар.	●	MWE0750MA	45	45	87	7.5	1
7.6	2	Нар.	★	MWE0760SA	37	37	79	7.6	1
	3	Нар.	●	MWE0760MA	48	48	90	7.6	1
7.7	2	Нар.	★	MWE0770SA	37	37	79	7.7	1
	3	Нар.	●	MWE0770MA	48	48	90	7.7	1
7.8	2	Нар.	●	MWE0780SA	37	37	79	7.8	1
	3	Нар.	★	MWE0780MA	48	48	90	7.8	1
7.9	2	Нар.	★	MWE0790SA	37	37	79	7.9	1
	3	Нар.	★	MWE0790MA	48	48	90	7.9	1
8.0	2	Нар.	●	MWE0800SA	37	37	79	8	1
	3	Нар.	●	MWE0800MA	48	48	90	8	1
8.1	2	Нар.	●	MWE0810SA	37	37	79	8.1	1
	3	Нар.	●	MWE0810MA	53	53	96	8.1	1
8.2	2	Нар.	★	MWE0820SA	37	37	79	8.2	1
	3	Нар.	●	MWE0820MA	53	53	96	8.2	1
8.3	2	Нар.	★	MWE0830SA	37	37	79	8.3	1
	3	Нар.	●	MWE0830MA	53	53	96	8.3	1
8.4	2	Нар.	★	MWE0840SA	37	37	79	8.4	1
	3	Нар.	●	MWE0840MA	53	53	96	8.4	1
8.5	2	Нар.	●	MWE0850SA	37	37	79	8.5	1
	3	Нар.	●	MWE0850MA	53	53	96	8.5	1
8.6	2	Нар.	★	MWE0860SA	40	40	84	8.6	1
	3	Нар.	●	MWE0860MA	55	55	98	8.6	1
8.7	2	Нар.	★	MWE0870SA	40	40	84	8.7	1
	3	Нар.	●	MWE0870MA	55	55	98	8.7	1
8.8	2	Нар.	★	MWE0880SA	40	40	84	8.8	1
	3	Нар.	●	MWE0880MA	55	55	98	8.8	1
8.9	2	Нар.	★	MWE0890SA	40	40	84	8.9	1
	3	Нар.	★	MWE0890MA	55	55	98	8.9	1
9.0	2	Нар.	●	MWE0900SA	40	40	84	9	1
	3	Нар.	●	MWE0900MA	55	55	98	9	1

Диам. сверла D1 (мм)	Глубина сверления (l/d)	Охлаждение (Внут./Нар.)	Наличие VP15TF	Обозначение	Размеры (мм)				Тип
					L3	L2	L1	D4	
9.1	2	Нар.	●	MWE0910SA	40	40	84	9.1	1
	3	Нар.	●	MWE0910MA	58	58	102	9.1	1
9.2	2	Нар.	●	MWE0920SA	40	40	84	9.2	1
	3	Нар.	●	MWE0920MA	58	58	102	9.2	1
9.3	2	Нар.	★	MWE0930SA	40	40	81	9.3	1
	3	Нар.	★	MWE0930MA	58	58	102	9.3	1
9.4	2	Нар.	★	MWE0940SA	40	40	84	9.4	1
	3	Нар.	★	MWE0940MA	58	58	102	9.4	1
9.5	2	Нар.	★	MWE0950SA	40	40	84	9.5	1
	3	Нар.	●	MWE0950MA	58	58	102	9.5	1
9.6	2	Нар.	★	MWE0960SA	43	43	89	9.6	1
	3	Нар.	●	MWE0960MA	60	60	105	9.6	1
9.7	2	Нар.	★	MWE0970SA	43	43	89	9.7	1
	3	Нар.	●	MWE0970MA	60	60	105	9.7	1
9.8	2	Нар.	★	MWE0980SA	43	43	89	9.8	1
	3	Нар.	★	MWE0980MA	60	60	105	9.8	1
9.9	2	Нар.	★	MWE0990SA	43	43	89	9.9	1
	3	Нар.	★	MWE0990MA	60	60	105	9.9	1
10.0	2	Нар.	●	MWE1000SA	43	43	89	10	1
	3	Нар.	●	MWE1000MA	60	60	105	10	1
10.1	2	Нар.	★	MWE1010SA	43	43	89	10.1	1
	3	Нар.	●	MWE1010MA	66	66	112	10.1	1
10.2	2	Нар.	●	MWE1020SA	43	43	89	10.2	1
	3	Нар.	●	MWE1020MA	66	66	112	10.2	1
10.3	2	Нар.	★	MWE1030SA	43	43	89	10.3	1
	3	Нар.	●	MWE1030MA	66	66	112	10.3	1
10.4	2	Нар.	★	MWE1040SA	43	43	89	10.4	1
	3	Нар.	●	MWE1040MA	66	66	112	10.4	1
10.5	2	Нар.	●	MWE1050SA	43	43	89	10.5	1
	3	Нар.	●	MWE1050MA	66	66	112	10.5	1
10.6	2	Нар.	★	MWE1060SA	43	43	89	10.6	1
	3	Нар.	★	MWE1060MA	68	68	114	10.6	1
10.7	2	Нар.	★	MWE1070SA	47	47	95	10.7	1
	3	Нар.	★	MWE1070MA	68	68	114	10.7	1
10.8	2	Нар.	★	MWE1080SA	47	47	95	10.8	1
	3	Нар.	●	MWE1080MA	68	68	114	10.8	1
10.9	2	Нар.	★	MWE1090SA	47	47	95	10.9	1
	3	Нар.	★	MWE1090MA	68	68	114	10.9	1
11.0	2	Нар.	●	MWE1100SA	47	47	95	11	1
	3	Нар.	●	MWE1100MA	68	68	114	11	1
11.1	2	Нар.	★	MWE1110SA	47	47	95	11.1	1
	3	Нар.	●	MWE1110MA	71	71	118	11.1	1
11.2	2	Нар.	●	MWE1120SA	47	47	95	11.2	1
	3	Нар.	●	MWE1120MA	71	71	118	11.2	1
11.3	2	Нар.	★	MWE1130SA	47	47	95	11.3	1
	3	Нар.	★	MWE1130MA	71	71	118	11.3	1
11.4	2	Нар.	★	MWE1140SA	47	47	95	11.4	1
	3	Нар.	★	MWE1140MA	71	71	118	11.4	1
11.5	2	Нар.	★	MWE1150SA	47	47	95	11.5	1
	3	Нар.	●	MWE1150MA	71	71	118	11.5	1

РЕЖИМЫ РЕЗАНИЯ > L026  
 ИНСТРУКЦИЯ ПО ЭКСПЛУАТАЦИИ > L027  
 ТЕХНИЧЕСКИЕ ДАННЫЕ > N001

# СВЕРЛЕНИЕ (МОНОЛИТНЫЕ ТВЕРДОСПЛАВНЫЕ СВЕРЛА)

## MWE

ТВЕРДЫЙ  
СПЛАВ

Диам. сверла D1 (мм)	Глубина сверления (l/d)	Охлаждение (Внут./Нар.)	Наличие VP15TF	Обозначение	Размеры (мм)				Тип
					L3	L2	L1	D4	
11.6	2	Нар.	★	MWE1160SA	47	47	95	11.6	1
	3	Нар.	★	MWE1160MA	73	73	121	11.6	1
11.7	2	Нар.	★	MWE1170SA	47	47	95	11.7	1
	3	Нар.	●	MWE1170MA	73	73	121	11.7	1
11.8	2	Нар.	★	MWE1180SA	47	47	95	11.8	1
	3	Нар.	●	MWE1180MA	73	73	121	11.8	1
11.9	2	Нар.	★	MWE1190SA	51	51	102	11.9	1
	3	Нар.	★	MWE1190MA	73	73	121	11.9	1
12.0	2	Нар.	●	MWE1200SA	51	51	102	12	1
	3	Нар.	●	MWE1200MA	73	73	121	12	1
12.1	2	Нар.	★	MWE1210SA	51	51	102	12.1	1
	3	Нар.	●	MWE1210MA	76	76	135	12.1	1
12.2	2	Нар.	★	MWE1220SA	51	51	102	12.2	1
	3	Нар.	●	MWE1220MA	76	76	135	12.2	1
12.3	2	Нар.	★	MWE1230SA	51	51	102	12.3	1
	3	Нар.	●	MWE1230MA	76	76	135	12.3	1
12.4	2	Нар.	★	MWE1240SA	51	51	102	12.4	1
	3	Нар.	★	MWE1240MA	76	76	135	12.4	1
12.5	2	Нар.	★	MWE1250SA	51	51	102	12.5	1
	3	Нар.	●	MWE1250MA	76	76	135	12.5	1
12.6	2	Нар.	★	MWE1260SA	51	51	102	12.6	1
	3	Нар.	★	MWE1260MA	78	78	137	12.6	1
12.7	2	Нар.	★	MWE1270SA	51	51	102	12.7	1
	3	Нар.	●	MWE1270MA	78	78	137	12.7	1
12.8	2	Нар.	★	MWE1280SA	51	51	102	12.8	1
	3	Нар.	★	MWE1280MA	78	78	137	12.8	1
12.9	2	Нар.	★	MWE1290SA	51	51	102	12.9	1
	3	Нар.	★	MWE1290MA	78	78	137	12.9	1
13.0	2	Нар.	●	MWE1300SA	51	51	102	13	1
	3	Нар.	●	MWE1300MA	78	78	137	13	1
13.1	2	Нар.	★	MWE1310SA	51	51	102	13.1	1
	3	Нар.	●	MWE1310MA	84	84	144	13.1	1
13.2	2	Нар.	★	MWE1320SA	51	51	102	13.2	1
	3	Нар.	★	MWE1320MA	84	84	144	13.2	1
13.3	2	Нар.	★	MWE1330SA	54	54	107	13.3	1
	3	Нар.	★	MWE1330MA	84	84	144	13.3	1
13.4	2	Нар.	★	MWE1340SA	54	54	107	13.4	1
	3	Нар.	★	MWE1340MA	84	84	144	13.4	1
13.5	2	Нар.	●	MWE1350SA	54	54	107	13.5	1
	3	Нар.	●	MWE1350MA	84	84	144	13.5	1
13.6	2	Нар.	★	MWE1360SA	54	54	107	13.6	1
	3	Нар.	★	MWE1360MA	86	86	147	13.6	1
13.7	2	Нар.	★	MWE1370SA	54	54	107	13.7	1
	3	Нар.	●	MWE1370MA	86	86	147	13.7	1
13.8	2	Нар.	●	MWE1380SA	54	54	107	13.8	1
	3	Нар.	★	MWE1380MA	86	86	147	13.8	1
13.9	2	Нар.	★	MWE1390SA	54	54	107	13.9	1
	3	Нар.	★	MWE1390MA	86	86	147	13.9	1
14.0	2	Нар.	●	MWE1400SA	54	54	107	14	1
	3	Нар.	●	MWE1400MA	86	86	147	14	1

Диам. сверла D1 (мм)	Глубина сверления (l/d)	Охлаждение (Внут./Нар.)	Наличие VP15TF	Обозначение	Размеры (мм)				Тип
					L3	L2	L1	D4	
14.1	2	Нар.	★	MWE1410SA	56	56	111	14.1	1
	3	Нар.	★	MWE1410MA	89	89	151	14.1	1
14.2	2	Нар.	★	MWE1420SA	56	56	111	14.2	1
	3	Нар.	●	MWE1420MA	89	89	151	14.2	1
14.3	2	Нар.	□	MWE1430SA	56	56	111	14.3	1
	3	Нар.	★	MWE1430MA	89	89	151	14.3	1
14.4	2	Нар.	□	MWE1440SA	56	56	111	14.4	1
	3	Нар.	★	MWE1440MA	89	89	151	14.4	1
14.5	2	Нар.	●	MWE1450SA	56	56	111	14.5	1
	3	Нар.	●	MWE1450MA	89	89	151	14.5	1
14.6	2	Нар.	□	MWE1460SA	56	56	111	14.6	1
	3	Нар.	★	MWE1460MA	91	91	153	14.6	1
14.7	2	Нар.	□	MWE1470SA	56	56	111	14.7	1
	3	Нар.	★	MWE1470MA	91	91	153	14.7	1
14.8	2	Нар.	□	MWE1480SA	56	56	111	14.8	1
	3	Нар.	★	MWE1480MA	91	91	153	14.8	1
14.9	2	Нар.	□	MWE1490SA	56	56	111	14.9	1
	3	Нар.	★	MWE1490MA	91	91	153	14.9	1
15.0	2	Нар.	●	MWE1500SA	56	56	111	15	1
	3	Нар.	●	MWE1500MA	91	91	153	15	1
15.1	2	Нар.	□	MWE1510SA	58	58	115	15.1	1
	3	Нар.	★	MWE1510MA	94	94	157	15.1	1
15.2	2	Нар.	★	MWE1520SA	58	58	115	15.2	1
	3	Нар.	★	MWE1520MA	94	94	157	15.2	1
15.3	2	Нар.	□	MWE1530SA	58	58	115	15.3	1
	3	Нар.	★	MWE1530MA	94	94	157	15.3	1
15.4	2	Нар.	□	MWE1540SA	58	58	115	15.4	1
	3	Нар.	★	MWE1540MA	94	94	157	15.4	1
15.5	2	Нар.	●	MWE1550SA	58	58	115	15.5	1
	3	Нар.	★	MWE1550MA	94	94	157	15.5	1
15.6	2	Нар.	□	MWE1560SA	58	58	115	15.6	1
	3	Нар.	★	MWE1560MA	96	96	160	15.6	1
15.7	2	Нар.	□	MWE1570SA	58	58	115	15.7	1
	3	Нар.	★	MWE1570MA	96	96	160	15.7	1
15.8	2	Нар.	□	MWE1580SA	58	58	115	15.8	1
	3	Нар.	★	MWE1580MA	96	96	160	15.8	1
15.9	2	Нар.	□	MWE1590SA	58	58	115	15.9	1
	3	Нар.	★	MWE1590MA	96	96	160	15.9	1
16.0	2	Нар.	●	MWE1600SA	58	58	115	16	1
	3	Нар.	●	MWE1600MA	96	96	160	16	1
16.1	2	Нар.	□	MWE1610SA	60	60	119	16.1	1
	3	Нар.	□	MWE1610MA	102	102	167	16.1	1
16.2	2	Нар.	★	MWE1620SA	60	60	119	16.2	1
	3	Нар.	□	MWE1620MA	102	102	167	16.2	1
16.3	2	Нар.	★	MWE1630SA	60	60	119	16.3	1
	3	Нар.	□	MWE1630MA	102	102	167	16.3	1
16.4	2	Нар.	□	MWE1640SA	60	60	119	16.4	1
	3	Нар.	□	MWE1640MA	102	102	167	16.4	1
16.5	2	Нар.	★	MWE1650SA	60	60	119	16.5	1
	3	Нар.	●	MWE1650MA	102	102	167	16.5	1

(Примечание) Пожалуйста, свяжитесь с нами если Вы не нашли нужную геометрию в данном каталоге (могут быть заказаны другие диаметры и длины).

● : Есть на складе. ★ : Со склада в Японии.

□ : Нет на складе, выпускается исключительно под заказ.

L024

Диам. сверла D1 (мм)	Глубина сверления (l/d)	Охлаждение (Внут./Нар.)	Наличие VP15TF	Обозначение	Размеры (мм)				Тип
					L3	L2	L1	D4	
16.6	2	Нар.	□	MWE1660SA	60	60	119	16.6	1
	3	Нар.	□	MWE1660MA	102	102	167	16.6	1
16.7	2	Нар.	□	MWE1670SA	60	60	119	16.7	1
	3	Нар.	□	MWE1670MA	102	102	167	16.7	1
16.8	2	Нар.	□	MWE1680SA	60	60	119	16.8	1
	3	Нар.	□	MWE1680MA	102	102	167	16.8	1
16.9	2	Нар.	□	MWE1690SA	60	60	119	16.9	1
	3	Нар.	□	MWE1690MA	102	102	167	16.9	1
17.0	2	Нар.	●	MWE1700SA	60	60	119	17	1
	3	Нар.	●	MWE1700MA	102	102	167	17	1
17.1	2	Нар.	□	MWE1710SA	62	62	123	17.1	1
	3	Нар.	□	MWE1710MA	102	102	167	17.1	1
17.2	2	Нар.	□	MWE1720SA	62	62	123	17.2	1
	3	Нар.	□	MWE1720MA	102	102	167	17.2	1
17.3	2	Нар.	□	MWE1730SA	62	62	123	17.3	1
	3	Нар.	□	MWE1730MA	102	102	167	17.3	1
17.4	2	Нар.	□	MWE1740SA	62	62	123	17.4	1
	3	Нар.	□	MWE1740MA	102	102	167	17.4	1
17.5	2	Нар.	●	MWE1750SA	62	62	123	17.5	1
	3	Нар.	●	MWE1750MA	102	102	167	17.5	1
17.6	2	Нар.	□	MWE1760SA	62	62	123	17.6	1
	3	Нар.	□	MWE1760MA	102	102	167	17.6	1
17.7	2	Нар.	□	MWE1770SA	62	62	123	17.7	1
	3	Нар.	□	MWE1770MA	102	102	167	17.7	1
17.8	2	Нар.	★	MWE1780SA	62	62	123	17.8	1
	3	Нар.	□	MWE1780MA	102	102	167	17.8	1
17.9	2	Нар.	□	MWE1790SA	62	62	123	17.9	1
	3	Нар.	□	MWE1790MA	102	102	167	17.9	1
18.0	2	Нар.	●	MWE1800SA	62	62	123	18	1
	3	Нар.	●	MWE1800MA	102	102	167	18	1
18.1	2	Нар.	□	MWE1810SA	64	64	127	18.1	1
	3	Нар.	□	MWE1810MA	114	114	179	18.1	1
18.2	2	Нар.	□	MWE1820SA	64	64	127	18.2	1
	3	Нар.	□	MWE1820MA	114	114	179	18.2	1
18.3	2	Нар.	□	MWE1830SA	64	64	127	18.3	1
	3	Нар.	□	MWE1830MA	114	114	179	18.3	1
18.4	2	Нар.	□	MWE1840SA	64	64	127	18.4	1
	3	Нар.	□	MWE1840MA	114	114	179	18.4	1
18.5	2	Нар.	●	MWE1850SA	64	64	127	18.5	1
	3	Нар.	●	MWE1850MA	114	114	179	18.5	1
18.6	2	Нар.	□	MWE1860SA	64	64	127	18.6	1
	3	Нар.	□	MWE1860MA	114	114	179	18.6	1
18.7	2	Нар.	□	MWE1870SA	64	64	127	18.7	1
	3	Нар.	□	MWE1870MA	114	114	179	18.7	1
18.8	2	Нар.	□	MWE1880SA	64	64	127	18.8	1
	3	Нар.	□	MWE1880MA	114	114	179	18.8	1
18.9	2	Нар.	□	MWE1890SA	64	64	127	18.9	1
	3	Нар.	□	MWE1890MA	114	114	179	18.9	1
19.0	2	Нар.	●	MWE1900SA	64	64	127	19	1
	3	Нар.	★	MWE1900MA	114	114	179	19	1

Диам. сверла D1 (мм)	Глубина сверления (l/d)	Охлаждение (Внут./Нар.)	Наличие VP15TF	Обозначение	Размеры (мм)				Тип
					L3	L2	L1	D4	
19.1	2	Нар.	□	MWE1910SA	66	66	131	19.1	1
	3	Нар.	□	MWE1910MA	114	114	179	19.1	1
19.2	2	Нар.	□	MWE1920SA	66	66	131	19.2	1
	3	Нар.	□	MWE1920MA	114	114	179	19.2	1
19.3	2	Нар.	□	MWE1930SA	66	66	131	19.3	1
	3	Нар.	□	MWE1930MA	114	114	179	19.3	1
19.4	2	Нар.	□	MWE1940SA	66	66	131	19.4	1
	3	Нар.	□	MWE1940MA	114	114	179	19.4	1
19.5	2	Нар.	●	MWE1950SA	66	66	131	19.5	1
	3	Нар.	★	MWE1950MA	114	114	179	19.5	1
19.6	2	Нар.	□	MWE1960SA	66	66	131	19.6	1
	3	Нар.	□	MWE1960MA	114	114	179	19.6	1
19.7	2	Нар.	□	MWE1970SA	66	66	131	19.7	1
	3	Нар.	□	MWE1970MA	114	114	179	19.7	1
19.8	2	Нар.	□	MWE1980SA	66	66	131	19.8	1
	3	Нар.	□	MWE1980MA	114	114	179	19.8	1
19.9	2	Нар.	□	MWE1990SA	66	66	131	19.9	1
	3	Нар.	□	MWE1990MA	114	114	179	19.9	1
20.0	2	Нар.	●	MWE2000SA	66	66	131	20	1
	3	Нар.	●	MWE2000MA	114	114	179	20	1

### РЕКОМЕНДУЕМЫЕ РЕЖИМЫ РЕЗАНИЯ

Обрабатываемый материал	Малоуглеродистая сталь ( $\leq 180\text{HB}$ )		Углеродистая сталь Легированная сталь (180—280HB)		Углеродистая сталь Легированная сталь (280—350HB)	
	Ck10		Ck45, 42CrMo4		36CrNiMo4	
Диам. сверла (мм)	Частота вращения (мин <sup>-1</sup> )	Подача (мин.—макс.) (мм/об)	Частота вращения (мин <sup>-1</sup> )	Подача (мин.—макс.) (мм/об)	Частота вращения (мин <sup>-1</sup> )	Подача (мин.—макс.) (мм/об)
3.0	6400	0.1 (0.06—0.13)	5900	0.1 (0.06—0.13)	5400	0.09 (0.06—0.12)
4.0	5500	0.12 (0.08—0.16)	5100	0.12 (0.08—0.16)	4700	0.11 (0.07—0.14)
5.0	4400	0.15 (0.10—0.20)	4100	0.15 (0.10—0.20)	3800	0.14 (0.09—0.18)
6.3	4000	0.2 (0.13—0.26)	3700	0.2 (0.13—0.26)	3500	0.18 (0.11—0.24)
8.0	3300	0.23 (0.18—0.28)	3100	0.23 (0.18—0.28)	2900	0.21 (0.16—0.25)
10.0	2800	0.27 (0.22—0.32)	2700	0.27 (0.22—0.32)	2500	0.23 (0.19—0.27)
12.0	2500	0.31 (0.28—0.34)	2300	0.31 (0.28—0.34)	2200	0.26 (0.23—0.29)
16.0	1900	0.33 (0.28—0.38)	1700	0.33 (0.28—0.38)	1600	0.29 (0.24—0.33)
20.0	1500	0.35 (0.30—0.40)	1400	0.35 (0.30—0.40)	1300	0.3 (0.26—0.34)

Обрабатываемый материал	Аустенитная нержавеющая сталь ( $\leq 200\text{HB}$ )		Серый чугун ( $\leq 350\text{MPa}$ )		Ковкий чугун ( $\leq 450\text{MPa}$ )	
	X5CrNi1810, X5CrNiMo17-12-2		GG30		GGG45	
Диам. сверла (мм)	Частота вращения (мин <sup>-1</sup> )	Подача (мин.—макс.) (мм/об)	Частота вращения (мин <sup>-1</sup> )	Подача (мин.—макс.) (мм/об)	Частота вращения (мин <sup>-1</sup> )	Подача (мин.—макс.) (мм/об)
3.0	1900	0.07 (0.05—0.08)	6900	0.1 (0.06—0.13)	6400	0.1 (0.06—0.13)
4.0	1500	0.08 (0.06—0.10)	5500	0.12 (0.08—0.16)	5100	0.12 (0.08—0.16)
5.0	1200	0.1 (0.07—0.13)	4400	0.15 (0.10—0.20)	4100	0.15 (0.10—0.20)
6.3	1200	0.13 (0.09—0.17)	3700	0.2 (0.13—0.26)	3500	0.2 (0.13—0.26)
8.0	900	0.14 (0.10—0.18)	2900	0.25 (0.18—0.31)	2700	0.23 (0.18—0.28)
10.0	700	0.16 (0.12—0.19)	2300	0.29 (0.22—0.35)	2200	0.27 (0.22—0.32)
12.0	600	0.18 (0.15—0.20)	2100	0.33 (0.28—0.37)	1900	0.31 (0.28—0.34)
16.0	400	0.19 (0.15—0.23)	1500	0.35 (0.28—0.42)	1400	0.33 (0.28—0.38)
20.0	300	0.2 (0.15—0.24)	1300	0.37 (0.30—0.44)	1200	0.35 (0.30—0.40)

Обрабатываемый материал	Алюминиевые сплавы (Si<5%)		Жаропрочные сплавы		Закалённая Сталь (40—55HRC)	
			Inconel718		X40CrMoV51, 55NiCrMoV7	
Диам. сверла (мм)	Частота вращения (мин <sup>-1</sup> )	Подача (мин.—макс.) (мм/об)	Частота вращения (мин <sup>-1</sup> )	Подача (мин.—макс.) (мм/об)	Частота вращения (мин <sup>-1</sup> )	Подача (мин.—макс.) (мм/об)
3.0	7900	0.1 (0.06—0.13)	1900	0.07 (0.05—0.09)	1900	0.07 (0.05—0.09)
4.0	6300	0.12 (0.08—0.16)	1500	0.09 (0.06—0.11)	1500	0.09 (0.06—0.11)
5.0	5000	0.15 (0.10—0.20)	1200	0.11 (0.08—0.14)	1200	0.11 (0.08—0.14)
6.3	4500	0.2 (0.13—0.26)	1200	0.14 (0.09—0.19)	1200	0.14 (0.09—0.19)
8.0	3500	0.23 (0.18—0.28)	900	0.14 (0.11—0.17)	900	0.14 (0.11—0.17)
10.0	2800	0.27 (0.22—0.32)	700	0.16 (0.12—0.19)	700	0.16 (0.12—0.19)
12.0	2600	0.31 (0.28—0.34)	600	0.16 (0.13—0.18)	600	0.16 (0.13—0.18)
16.0	1900	0.33 (0.28—0.38)	400	0.18 (0.14—0.21)	400	0.18 (0.14—0.21)
20.0	1700	0.35 (0.30—0.40)	400	0.19 (0.15—0.22)	400	0.19 (0.15—0.22)

## ИНСТРУКЦИЯ ПО ЭКСПЛУАТАЦИИ

### Крепление сверла

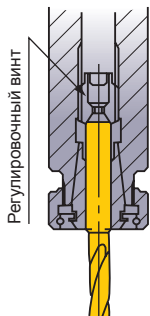

Регулируемый винт

Цанговый патрон с упорным подшипником надежно держит сверло.

### Длина сверла

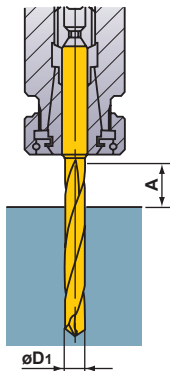

$$A \geq D_1 \times 1.5$$

### Установка сверла

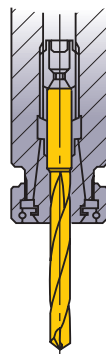

Не прижимать по режущей кромке.

### Допуск на установку

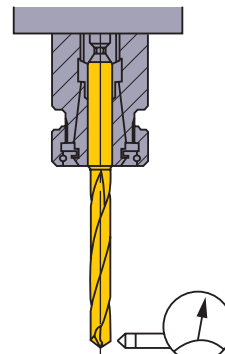

Биение  $\leq 0.03\text{мм}$

### Метод охлаждения

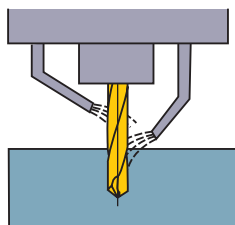

В идеале необходимы две позиции охлаждения - в конце и в центре.

### Установка сверла

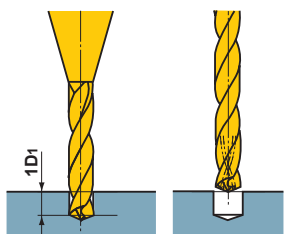

- 1 При предварительной обработке отверстия сверлом особо короткой серии установите глубину  $1D$  ( $D$ =диаметр сверла).
- 2 Применяя сверло с отверстием для подачи СОЖ, используйте предварительно обработанное отверстие как направляющее. В зависимости от режимов обработки рекомендуется подача с периодическим выводом сверла из отверстия.

### Тонкая заготовка

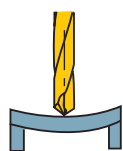

Если наблюдается отгиб.

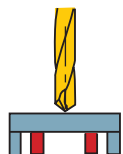

Необходима опора для заготовки.

### Прерывистое резание

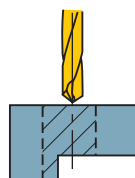

Один процесс

- 1 Уменьшить подачу при сверлении разомкнутой детали (при прерывистом сверлении).

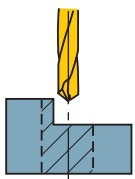

Требуется предварительная обработка.

- 1 До сверления предварительно подрезать торец концевой фрезой.

### Ступенчатые отверстия.

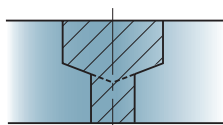

- 1 Разделите два указанных процесса.
  - 2 Сначала просверлите отверстие большего диаметра.
- \* Инструмент, применимый как для снятия фаски, так и для подрезки торца, может быть изготовлен на заказ.

### Образование заусенцев и выкрашивание заготовки.

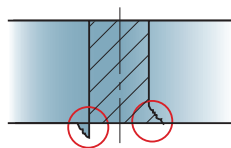

- 1 Снизить скорость подачи на 50% в конце сквозной обработки.
- 2 Добавить фаску  $45^\circ$
- 3 Измените угол при вершине.

# СВЕРЛЕНИЕ (МОНОЛИТНЫЕ ТВЕРДОСПЛАВНЫЕ СВЕРЛА)

## MPS1

- Новое многофункциональное покрытие PVD на основе AlTiCrN.
- Тип MPS с двойной ленточкой для точного и надежного сверления.
- Все сверла имеют отверстия для внутреннего охлаждения.

Тип с двойной ленточкой



ТВЕРДЫЙ СПЛАВ

Углеродистая сталь Легированная сталь	Закалённая сталь	Нержавеющая сталь	Чугун	Лёгкий сплав	Жаропрочные сплавы
○		○	○		

	3 ≤ D1 ≤ 6	6 < D1 ≤ 10	10 < D1 ≤ 18	18 < D1 ≤ 20
	+0.010 -0.002	+0.010 -0.005	+0.005 -0.013	+0.005 -0.016
	0 -0.008	0 -0.009	0 -0.011	0 -0.013



\*Отверстие для подачи СОЖ диаметром не более ø6 мм будет иметь круглую форму.

### ● Тип 1 Цилиндрический хвостовик с коническая шейка

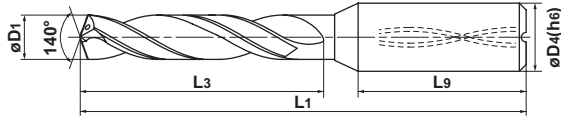

MPS1----S/L-DIN-C

### ● Тип 2 Цилиндрический хвостовик

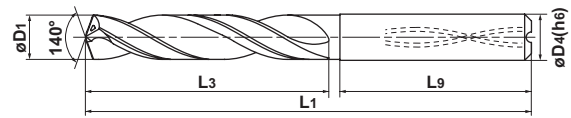

MPS1----S/L-DIN-C

### ● Тип 3 Хвостовик с лыской с коническая шейка

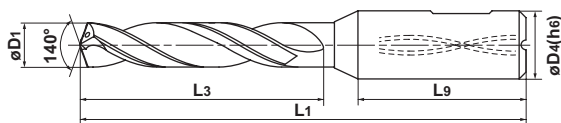

MPS1----S/L-DIN (Whistle notch)

### ● Тип 4 Хвостовик с лыской

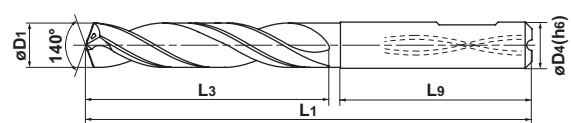

MPS1----S/L-DIN (Whistle notch)

Диам. сверла D1 (мм)	Глубина сверления (l/d)	Наличие		Обозначение	Размеры (мм)				Тип
		DP1021			L1	L3	L9	D4	
3.0	3	<input type="checkbox"/>		MPS1-0300S-DIN	62	20	36	6	3
	3	<input checked="" type="checkbox"/>		-0300S-DIN-C	62	20	36	6	1
	5	<input type="checkbox"/>		-0300L-DIN	66	25	36	6	3
	5	<input checked="" type="checkbox"/>		-0300L-DIN-C	66	25	36	6	1
3.05	3	<input type="checkbox"/>		-0305S-DIN	62	20	36	6	3
	3	<input checked="" type="checkbox"/>		-0305S-DIN-C	62	20	36	6	1
	5	<input type="checkbox"/>		-0305L-DIN	66	25	36	6	3
	5	<input checked="" type="checkbox"/>		-0305L-DIN-C	66	25	36	6	1
3.1	3	<input type="checkbox"/>		-0310S-DIN	62	20	36	6	3
	3	<input checked="" type="checkbox"/>		-0310S-DIN-C	62	20	36	6	1
	5	<input type="checkbox"/>		-0310L-DIN	66	25	36	6	3
	5	<input checked="" type="checkbox"/>		-0310L-DIN-C	66	25	36	6	1
3.2	3	<input type="checkbox"/>		-0320S-DIN	62	20	36	6	3
	3	<input checked="" type="checkbox"/>		-0320S-DIN-C	62	20	36	6	1
	5	<input type="checkbox"/>		-0320L-DIN	66	25	36	6	3
	5	<input checked="" type="checkbox"/>		-0320L-DIN-C	66	25	36	6	1
3.3	3	<input type="checkbox"/>		-0330S-DIN	62	20	36	6	3
	3	<input checked="" type="checkbox"/>		-0330S-DIN-C	62	20	36	6	1
	5	<input type="checkbox"/>		-0330L-DIN	66	25	36	6	3
	5	<input checked="" type="checkbox"/>		-0330L-DIN-C	66	25	36	6	1
3.4	3	<input type="checkbox"/>		-0340S-DIN	62	20	36	6	3
	3	<input checked="" type="checkbox"/>		-0340S-DIN-C	62	20	36	6	1
	5	<input type="checkbox"/>		-0340L-DIN	66	25	36	6	3
	5	<input checked="" type="checkbox"/>		-0340L-DIN-C	66	25	36	6	1
3.5	3	<input type="checkbox"/>		-0350S-DIN	62	20	36	6	3
	3	<input checked="" type="checkbox"/>		-0350S-DIN-C	62	20	36	6	1
	5	<input type="checkbox"/>		-0350L-DIN	66	25	36	6	3
	5	<input checked="" type="checkbox"/>		-0350L-DIN-C	66	25	36	6	1
3.6	3	<input type="checkbox"/>		-0360S-DIN	62	20	36	6	3
	3	<input checked="" type="checkbox"/>		-0360S-DIN-C	62	20	36	6	1
	5	<input type="checkbox"/>		-0360L-DIN	66	25	36	6	3
	5	<input checked="" type="checkbox"/>		-0360L-DIN-C	66	25	36	6	1
3.7	3	<input type="checkbox"/>		-0370S-DIN	62	20	36	6	3
	3	<input checked="" type="checkbox"/>		-0370S-DIN-C	62	20	36	6	1
	5	<input type="checkbox"/>		-0370L-DIN	66	26	36	6	3
	5	<input checked="" type="checkbox"/>		-0370L-DIN-C	66	26	36	6	1

Диам. сверла D1 (мм)	Глубина сверления (l/d)	Наличие		Обозначение	Размеры (мм)				Тип
		DP1021			L1	L3	L9	D4	
3.8	3	<input type="checkbox"/>		MPS1-0380S-DIN	66	24	36	6	3
	3	<input checked="" type="checkbox"/>		-0380S-DIN-C	66	24	36	6	1
	5	<input type="checkbox"/>		-0380L-DIN	74	34	36	6	3
	5	<input checked="" type="checkbox"/>		-0380L-DIN-C	74	34	36	6	1
3.9	3	<input type="checkbox"/>		-0390S-DIN	66	24	36	6	3
	3	<input checked="" type="checkbox"/>		-0390S-DIN-C	66	24	36	6	1
	5	<input type="checkbox"/>		-0390L-DIN	74	34	36	6	3
	5	<input checked="" type="checkbox"/>		-0390L-DIN-C	74	34	36	6	1
4.0	3	<input type="checkbox"/>		-0400S-DIN	66	24	36	6	3
	3	<input checked="" type="checkbox"/>		-0400S-DIN-C	66	24	36	6	1
	5	<input type="checkbox"/>		-0400L-DIN	74	34	36	6	3
	5	<input checked="" type="checkbox"/>		-0400L-DIN-C	74	34	36	6	1
4.05	3	<input type="checkbox"/>		-0405S-DIN	66	24	36	6	3
	3	<input checked="" type="checkbox"/>		-0405S-DIN-C	66	24	36	6	1
	5	<input type="checkbox"/>		-0405L-DIN	74	34	36	6	3
	5	<input checked="" type="checkbox"/>		-0405L-DIN-C	74	34	36	6	1
4.1	3	<input type="checkbox"/>		-0410S-DIN	66	24	36	6	3
	3	<input checked="" type="checkbox"/>		-0410S-DIN-C	66	24	36	6	1
	5	<input type="checkbox"/>		-0410L-DIN	74	34	36	6	3
	5	<input checked="" type="checkbox"/>		-0410L-DIN-C	74	34	36	6	1
4.2	3	<input type="checkbox"/>		-0420S-DIN	66	24	36	6	3
	3	<input checked="" type="checkbox"/>		-0420S-DIN-C	66	24	36	6	1
	5	<input type="checkbox"/>		-0420L-DIN	74	34	36	6	3
	5	<input checked="" type="checkbox"/>		-0420L-DIN-C	74	34	36	6	1
4.3	3	<input type="checkbox"/>		-0430S-DIN	66	24	36	6	3
	3	<input checked="" type="checkbox"/>		-0430S-DIN-C	66	24	36	6	1
	5	<input type="checkbox"/>		-0430L-DIN	74	34	36	6	3
	5	<input checked="" type="checkbox"/>		-0430L-DIN-C	74	34	36	6	1
4.4	3	<input type="checkbox"/>		-0440S-DIN	66	24	36	6	3
	3	<input checked="" type="checkbox"/>		-0440S-DIN-C	66	24	36	6	1
	5	<input type="checkbox"/>		-0440L-DIN	74	34	36	6	3
	5	<input checked="" type="checkbox"/>		-0440L-DIN-C	74	34	36	6	1
4.5	3	<input type="checkbox"/>		-0450S-DIN	66	24	36	6	3
	3	<input checked="" type="checkbox"/>		-0450S-DIN-C	66	24	36	6	1
	5	<input type="checkbox"/>		-0450L-DIN	74	34	36	6	3
	5	<input checked="" type="checkbox"/>		-0450L-DIN-C	74	34	36	6	1

● : Есть на складе. □ : Нет на складе, выпускается исключительно под заказ.

Диам. сверла D1 (мм)	Глубина сверления (l/d)	Наличие		Обозначение	Размеры (мм)				Тип
		DP1021			L1	L3	L9	D4	
4.6	3	□		MPS1-0460S-DIN	66	24	36	6	4
	3	●		-0460S-DIN-C	66	24	36	6	2
	5	□		-0460L-DIN	74	36	36	6	4
	5	●		-0460L-DIN-C	74	36	36	6	2
4.65	3	□		-0465S-DIN	66	24	36	6	4
	3	●		-0465S-DIN-C	66	24	36	6	2
	5	□		-0465L-DIN	74	36	36	6	4
	5	●		-0465L-DIN-C	74	36	36	6	2
4.7	3	□		-0470S-DIN	66	24	36	6	4
	3	●		-0470S-DIN-C	66	24	36	6	2
	5	□		-0470L-DIN	74	36	36	6	4
	5	●		-0470L-DIN-C	74	36	36	6	2
4.8	3	□		-0480S-DIN	66	28	36	6	4
	3	●		-0480S-DIN-C	66	28	36	6	2
	5	□		-0480L-DIN	82	44	36	6	4
	5	●		-0480L-DIN-C	82	44	36	6	2
4.9	3	□		-0490S-DIN	66	28	36	6	4
	3	●		-0490S-DIN-C	66	28	36	6	2
	5	□		-0490L-DIN	82	44	36	6	4
	5	●		-0490L-DIN-C	82	44	36	6	2
5.0	3	□		-0500S-DIN	66	28	36	6	4
	3	●		-0500S-DIN-C	66	28	36	6	2
	5	□		-0500L-DIN	82	44	36	6	4
	5	●		-0500L-DIN-C	82	44	36	6	2
5.05	3	□		-0505S-DIN	66	28	36	6	4
	3	●		-0505S-DIN-C	66	28	36	6	2
	5	□		-0505L-DIN	82	44	36	6	4
	5	●		-0505L-DIN-C	82	44	36	6	2
5.1	3	□		-0510S-DIN	66	28	36	6	4
	3	●		-0510S-DIN-C	66	28	36	6	2
	5	□		-0510L-DIN	82	44	36	6	4
	5	●		-0510L-DIN-C	82	44	36	6	2
5.2	3	□		-0520S-DIN	66	28	36	6	4
	3	●		-0520S-DIN-C	66	28	36	6	2
	5	□		-0520L-DIN	82	44	36	6	4
	5	●		-0520L-DIN-C	82	44	36	6	2
5.3	3	□		-0530S-DIN	66	28	36	6	4
	3	●		-0530S-DIN-C	66	28	36	6	2
	5	□		-0530L-DIN	82	44	36	6	4
	5	●		-0530L-DIN-C	82	44	36	6	2
5.4	3	□		-0540S-DIN	66	28	36	6	4
	3	●		-0540S-DIN-C	66	28	36	6	2
	5	□		-0540L-DIN	82	44	36	6	4
	5	●		-0540L-DIN-C	82	44	36	6	2
5.5	3	□		-0550S-DIN	66	28	36	6	4
	3	●		-0550S-DIN-C	66	28	36	6	2
	5	□		-0550L-DIN	82	44	36	6	4
	5	●		-0550L-DIN-C	82	44	36	6	2
5.55	3	□		-0555S-DIN	66	28	36	6	4
	3	●		-0555S-DIN-C	66	28	36	6	2
	5	□		-0555L-DIN	82	44	36	6	4
	5	●		-0555L-DIN-C	82	44	36	6	2
5.6	3	□		-0560S-DIN	66	28	36	6	4
	3	●		-0560S-DIN-C	66	28	36	6	2
	5	□		-0560L-DIN	82	44	36	6	4
	5	●		-0560L-DIN-C	82	44	36	6	2

Диам. сверла D1 (мм)	Глубина сверления (l/d)	Наличие		Обозначение	Размеры (мм)				Тип
		DP1021			L1	L3	L9	D4	
5.7	3	□		MPS1-0570S-DIN	66	28	36	6	4
	3	●		-0570S-DIN-C	66	28	36	6	2
	5	□		-0570L-DIN	82	44	36	6	4
	5	●		-0570L-DIN-C	82	44	36	6	2
5.8	3	□		-0580S-DIN	66	28	36	6	4
	3	●		-0580S-DIN-C	66	28	36	6	2
	5	□		-0580L-DIN	82	44	36	6	4
	5	●		-0580L-DIN-C	82	44	36	6	2
5.9	3	□		-0590S-DIN	66	28	36	6	4
	3	●		-0590S-DIN-C	66	28	36	6	2
	5	□		-0590L-DIN	82	44	36	6	4
	5	●		-0590L-DIN-C	82	44	36	6	2
6.0	3	□		-0600S-DIN	66	28	36	6	4
	3	●		-0600S-DIN-C	66	28	36	6	2
	5	□		-0600L-DIN	82	44	36	6	4
	5	●		-0600L-DIN-C	82	44	36	6	2
6.05	3	□		-0605S-DIN	79	34	36	8	4
	3	●		-0605S-DIN-C	79	34	36	8	2
	5	□		-0605L-DIN	91	53	36	8	4
	5	●		-0605L-DIN-C	91	53	36	8	2
6.1	3	□		-0610S-DIN	79	34	36	8	4
	3	●		-0610S-DIN-C	79	34	36	8	2
	5	□		-0610L-DIN	91	53	36	8	4
	5	●		-0610L-DIN-C	91	53	36	8	2
6.2	3	□		-0620S-DIN	79	34	36	8	4
	3	●		-0620S-DIN-C	79	34	36	8	2
	5	□		-0620L-DIN	91	53	36	8	4
	5	●		-0620L-DIN-C	91	53	36	8	2
6.3	3	□		-0630S-DIN	79	34	36	8	4
	3	●		-0630S-DIN-C	79	34	36	8	2
	5	□		-0630L-DIN	91	53	36	8	4
	5	●		-0630L-DIN-C	91	53	36	8	2
6.4	3	□		-0640S-DIN	79	34	36	8	4
	3	●		-0640S-DIN-C	79	34	36	8	2
	5	□		-0640L-DIN	91	53	36	8	4
	5	●		-0640L-DIN-C	91	53	36	8	2
6.5	3	□		-0650S-DIN	79	34	36	8	4
	3	●		-0650S-DIN-C	79	34	36	8	2
	5	□		-0650L-DIN	91	53	36	8	4
	5	●		-0650L-DIN-C	91	53	36	8	2
6.6	3	□		-0660S-DIN	79	34	36	8	4
	3	●		-0660S-DIN-C	79	34	36	8	2
	5	□		-0660L-DIN	91	53	36	8	4
	5	●		-0660L-DIN-C	91	53	36	8	2
6.7	3	□		-0670S-DIN	79	34	36	8	4
	3	●		-0670S-DIN-C	79	34	36	8	2
	5	□		-0670L-DIN	91	53	36	8	4
	5	●		-0670L-DIN-C	91	53	36	8	2
6.8	3	□		-0680S-DIN	79	34	36	8	4
	3	●		-0680S-DIN-C	79	34	36	8	2
	5	□		-0680L-DIN	91	53	36	8	4
	5	●		-0680L-DIN-C	91	53	36	8	2
6.9	3	□		-0690S-DIN	79	34	36	8	4
	3	●		-0690S-DIN-C	79	34	36	8	2
	5	□		-0690L-DIN	91	53	36	8	4
	5	●		-0690L-DIN-C	91	53	36	8	2

РЕЖИМЫ РЕЗАНИЯ > L033  
 ИНСТРУКЦИЯ ПО ЭКСПЛУАТАЦИИ > L034  
 ТЕХНИЧЕСКИЕ ДАННЫЕ > N001

**СВЕРЛЕНИЕ**

# СВЕРЛЕНИЕ (МОНОЛИТНЫЕ ТВЕРДОСПЛАВНЫЕ СВЕРЛА)

## MPS1

Тип с двойной ленточкой

ТВЕРДЫЙ  
СПЛАВ

СВЕРЛЕНИЕ

Диам. сверла D1 (мм)	Глубина сверления (l/d)	Наличие		Обозначение	Размеры (мм)				Тип
		DP1021			L1	L3	L9	D4	
7.0	3	<input type="checkbox"/>		MPS1-0700S-DIN	79	34	36	8	4
	3	<input checked="" type="checkbox"/>		-0700S-DIN-C	79	34	36	8	2
	5	<input type="checkbox"/>		-0700L-DIN	91	53	36	8	4
	5	<input checked="" type="checkbox"/>		-0700L-DIN-C	91	53	36	8	2
7.1	3	<input type="checkbox"/>		-0710S-DIN	79	41	36	8	4
	3	<input checked="" type="checkbox"/>		-0710S-DIN-C	79	41	36	8	2
	5	<input type="checkbox"/>		-0710L-DIN	91	53	36	8	4
	5	<input checked="" type="checkbox"/>		-0710L-DIN-C	91	53	36	8	2
7.2	3	<input type="checkbox"/>		-0720S-DIN	79	41	36	8	4
	3	<input checked="" type="checkbox"/>		-0720S-DIN-C	79	41	36	8	2
	5	<input type="checkbox"/>		-0720L-DIN	91	53	36	8	4
	5	<input checked="" type="checkbox"/>		-0720L-DIN-C	91	53	36	8	2
7.3	3	<input type="checkbox"/>		-0730S-DIN	79	41	36	8	4
	3	<input checked="" type="checkbox"/>		-0730S-DIN-C	79	41	36	8	2
	5	<input type="checkbox"/>		-0730L-DIN	91	53	36	8	4
	5	<input checked="" type="checkbox"/>		-0730L-DIN-C	91	53	36	8	2
7.4	3	<input type="checkbox"/>		-0740S-DIN	79	41	36	8	4
	3	<input checked="" type="checkbox"/>		-0740S-DIN-C	79	41	36	8	2
	5	<input type="checkbox"/>		-0740L-DIN	91	53	36	8	4
	5	<input checked="" type="checkbox"/>		-0740L-DIN-C	91	53	36	8	2
7.5	3	<input type="checkbox"/>		-0750S-DIN	79	41	36	8	4
	3	<input checked="" type="checkbox"/>		-0750S-DIN-C	79	41	36	8	2
	5	<input type="checkbox"/>		-0750L-DIN	91	53	36	8	4
	5	<input checked="" type="checkbox"/>		-0750L-DIN-C	91	53	36	8	2
7.6	3	<input type="checkbox"/>		-0760S-DIN	79	41	36	8	4
	3	<input checked="" type="checkbox"/>		-0760S-DIN-C	79	41	36	8	2
	5	<input type="checkbox"/>		-0760L-DIN	91	53	36	8	4
	5	<input checked="" type="checkbox"/>		-0760L-DIN-C	91	53	36	8	2
7.7	3	<input type="checkbox"/>		-0770S-DIN	79	41	36	8	4
	3	<input checked="" type="checkbox"/>		-0770S-DIN-C	79	41	36	8	2
	5	<input type="checkbox"/>		-0770L-DIN	91	53	36	8	4
	5	<input checked="" type="checkbox"/>		-0770L-DIN-C	91	53	36	8	2
7.8	3	<input type="checkbox"/>		-0780S-DIN	79	41	36	8	4
	3	<input checked="" type="checkbox"/>		-0780S-DIN-C	79	41	36	8	2
	5	<input type="checkbox"/>		-0780L-DIN	91	53	36	8	4
	5	<input checked="" type="checkbox"/>		-0780L-DIN-C	91	53	36	8	2
7.9	3	<input type="checkbox"/>		-0790S-DIN	79	41	36	8	4
	3	<input checked="" type="checkbox"/>		-0790S-DIN-C	79	41	36	8	2
	5	<input type="checkbox"/>		-0790L-DIN	91	53	36	8	4
	5	<input checked="" type="checkbox"/>		-0790L-DIN-C	91	53	36	8	2
8.0	3	<input type="checkbox"/>		-0800S-DIN	79	41	36	8	4
	3	<input checked="" type="checkbox"/>		-0800S-DIN-C	79	41	36	8	2
	5	<input type="checkbox"/>		-0800L-DIN	91	53	36	8	4
	5	<input checked="" type="checkbox"/>		-0800L-DIN-C	91	53	36	8	2
8.05	3	<input type="checkbox"/>		-0805S-DIN	88	46	40	10	4
	3	<input checked="" type="checkbox"/>		-0805S-DIN-C	88	46	40	10	2
	5	<input type="checkbox"/>		-0805L-DIN	102	60	40	10	4
	5	<input checked="" type="checkbox"/>		-0805L-DIN-C	102	60	40	10	2
8.1	3	<input type="checkbox"/>		-0810S-DIN	88	46	40	10	4
	3	<input checked="" type="checkbox"/>		-0810S-DIN-C	88	46	40	10	2
	5	<input type="checkbox"/>		-0810L-DIN	102	60	40	10	4
	5	<input checked="" type="checkbox"/>		-0810L-DIN-C	102	60	40	10	2
8.2	3	<input type="checkbox"/>		-0820S-DIN	88	46	40	10	4
	3	<input checked="" type="checkbox"/>		-0820S-DIN-C	88	46	40	10	2
	5	<input type="checkbox"/>		-0820L-DIN	102	60	40	10	4
	5	<input checked="" type="checkbox"/>		-0820L-DIN-C	102	60	40	10	2

Диам. сверла D1 (мм)	Глубина сверления (l/d)	Наличие		Обозначение	Размеры (мм)				Тип
		DP1021			L1	L3	L9	D4	
8.3	3	<input type="checkbox"/>		MPS1-0830S-DIN	88	46	40	10	4
	3	<input checked="" type="checkbox"/>		-0830S-DIN-C	88	46	40	10	2
	5	<input type="checkbox"/>		-0830L-DIN	102	60	40	10	4
	5	<input checked="" type="checkbox"/>		-0830L-DIN-C	102	60	40	10	2
8.4	3	<input type="checkbox"/>		-0840S-DIN	88	46	40	10	4
	3	<input checked="" type="checkbox"/>		-0840S-DIN-C	88	46	40	10	2
	5	<input type="checkbox"/>		-0840L-DIN	102	60	40	10	4
	5	<input checked="" type="checkbox"/>		-0840L-DIN-C	102	60	40	10	2
8.5	3	<input type="checkbox"/>		-0850S-DIN	88	46	40	10	4
	3	<input checked="" type="checkbox"/>		-0850S-DIN-C	88	46	40	10	2
	5	<input type="checkbox"/>		-0850L-DIN	102	60	40	10	4
	5	<input checked="" type="checkbox"/>		-0850L-DIN-C	102	60	40	10	2
8.6	3	<input type="checkbox"/>		-0860S-DIN	88	46	40	10	4
	3	<input checked="" type="checkbox"/>		-0860S-DIN-C	88	46	40	10	2
	5	<input type="checkbox"/>		-0860L-DIN	102	60	40	10	4
	5	<input checked="" type="checkbox"/>		-0860L-DIN-C	102	60	40	10	2
8.7	3	<input type="checkbox"/>		-0870S-DIN	88	46	40	10	4
	3	<input checked="" type="checkbox"/>		-0870S-DIN-C	88	46	40	10	2
	5	<input type="checkbox"/>		-0870L-DIN	102	60	40	10	4
	5	<input checked="" type="checkbox"/>		-0870L-DIN-C	102	60	40	10	2
8.8	3	<input type="checkbox"/>		-0880S-DIN	88	46	40	10	4
	3	<input checked="" type="checkbox"/>		-0880S-DIN-C	88	46	40	10	2
	5	<input type="checkbox"/>		-0880L-DIN	102	60	40	10	4
	5	<input checked="" type="checkbox"/>		-0880L-DIN-C	102	60	40	10	2
8.9	3	<input type="checkbox"/>		-0890S-DIN	88	46	40	10	4
	3	<input checked="" type="checkbox"/>		-0890S-DIN-C	88	46	40	10	2
	5	<input type="checkbox"/>		-0890L-DIN	102	60	40	10	4
	5	<input checked="" type="checkbox"/>		-0890L-DIN-C	102	60	40	10	2
9.0	3	<input type="checkbox"/>		-0900S-DIN	88	46	40	10	4
	3	<input checked="" type="checkbox"/>		-0900S-DIN-C	88	46	40	10	2
	5	<input type="checkbox"/>		-0900L-DIN	102	60	40	10	4
	5	<input checked="" type="checkbox"/>		-0900L-DIN-C	102	60	40	10	2
9.1	3	<input type="checkbox"/>		-0910S-DIN	89	47	40	10	4
	3	<input checked="" type="checkbox"/>		-0910S-DIN-C	89	47	40	10	2
	5	<input type="checkbox"/>		-0910L-DIN	103	62	40	10	4
	5	<input checked="" type="checkbox"/>		-0910L-DIN-C	103	62	40	10	2
9.2	3	<input type="checkbox"/>		-0920S-DIN	89	47	40	10	4
	3	<input checked="" type="checkbox"/>		-0920S-DIN-C	89	47	40	10	2
	5	<input type="checkbox"/>		-0920L-DIN	103	62	40	10	4
	5	<input checked="" type="checkbox"/>		-0920L-DIN-C	103	62	40	10	2
9.3	3	<input type="checkbox"/>		-0930S-DIN	89	47	40	10	4
	3	<input checked="" type="checkbox"/>		-0930S-DIN-C	89	47	40	10	2
	5	<input type="checkbox"/>		-0930L-DIN	103	62	40	10	4
	5	<input checked="" type="checkbox"/>		-0930L-DIN-C	103	62	40	10	2
9.4	3	<input type="checkbox"/>		-0940S-DIN	89	47	40	10	4
	3	<input checked="" type="checkbox"/>		-0940S-DIN-C	89	47	40	10	2
	5	<input type="checkbox"/>		-0940L-DIN	103	62	40	10	4
	5	<input checked="" type="checkbox"/>		-0940L-DIN-C	103	62	40	10	2
9.5	3	<input type="checkbox"/>		-0950S-DIN	89	47	40	10	4
	3	<input checked="" type="checkbox"/>		-0950S-DIN-C	89	47	40	10	2
	5	<input type="checkbox"/>		-0950L-DIN	103	62	40	10	4
	5	<input checked="" type="checkbox"/>		-0950L-DIN-C	103	62	40	10	2
9.6	3	<input type="checkbox"/>		-0960S-DIN	89	47	40	10	4
	3	<input checked="" type="checkbox"/>		-0960S-DIN-C	89	47	40	10	2
	5	<input type="checkbox"/>		-0960L-DIN	103	62	40	10	4
	5	<input checked="" type="checkbox"/>		-0960L-DIN-C	103	62	40	10	2

● : Есть на складе. □ : Нет на складе, выпускается исключительно под заказ.

L030

Диам. сверла D1 (мм)	Глубина сверления (l/d)	Наличие		Обозначение	Размеры (мм)				Тип
		DP1021			L1	L3	L9	D4	
9.7	3	□		MPS1-0970S-DIN	89	47	40	10	4
	3	●		-0970S-DIN-C	89	47	40	10	2
	5	□		-0970L-DIN	103	62	40	10	4
	5	●		-0970L-DIN-C	103	62	40	10	2
9.8	3	□		-0980S-DIN	89	47	40	10	4
	3	●		-0980S-DIN-C	89	47	40	10	2
	5	□		-0980L-DIN	103	62	40	10	4
	5	●		-0980L-DIN-C	103	62	40	10	2
9.9	3	□		-0990S-DIN	89	47	40	10	4
	3	●		-0990S-DIN-C	89	47	40	10	2
	5	□		-0990L-DIN	103	62	40	10	4
	5	●		-0990L-DIN-C	103	62	40	10	2
10.0	3	□		-1000S-DIN	89	47	40	10	4
	3	●		-1000S-DIN-C	89	47	40	10	2
	5	□		-1000L-DIN	103	62	40	10	4
	5	●		-1000L-DIN-C	103	62	40	10	2
10.05	3	□		-1005S-DIN	102	55	45	12	4
	3	●		-1005S-DIN-C	102	55	45	12	2
	5	□		-1005L-DIN	118	71	45	12	4
	5	●		-1005L-DIN-C	118	71	45	12	2
10.1	3	□		-1010S-DIN	102	55	45	12	4
	3	●		-1010S-DIN-C	102	55	45	12	2
	5	□		-1010L-DIN	118	71	45	12	4
	5	●		-1010L-DIN-C	118	71	45	12	2
10.2	3	□		-1020S-DIN	102	55	45	12	4
	3	●		-1020S-DIN-C	102	55	45	12	2
	5	□		-1020L-DIN	118	71	45	12	4
	5	●		-1020L-DIN-C	118	71	45	12	2
10.3	3	□		-1030S-DIN	102	55	45	12	4
	3	●		-1030S-DIN-C	102	55	45	12	2
	5	□		-1030L-DIN	118	71	45	12	4
	5	●		-1030L-DIN-C	118	71	45	12	2
10.4	3	□		-1040S-DIN	102	55	45	12	4
	3	●		-1040S-DIN-C	102	55	45	12	2
	5	□		-1040L-DIN	118	71	45	12	4
	5	●		-1040L-DIN-C	118	71	45	12	2
10.5	3	□		-1050S-DIN	102	55	45	12	4
	3	●		-1050S-DIN-C	102	55	45	12	2
	5	□		-1050L-DIN	118	71	45	12	4
	5	●		-1050L-DIN-C	118	71	45	12	2
10.6	3	□		-1060S-DIN	102	55	45	12	4
	3	●		-1060S-DIN-C	102	55	45	12	2
	5	□		-1060L-DIN	118	71	45	12	4
	5	●		-1060L-DIN-C	118	71	45	12	2
10.7	3	□		-1070S-DIN	102	55	45	12	4
	3	●		-1070S-DIN-C	102	55	45	12	2
	5	□		-1070L-DIN	118	71	45	12	4
	5	●		-1070L-DIN-C	118	71	45	12	2
10.8	3	□		-1080S-DIN	102	55	45	12	4
	3	●		-1080S-DIN-C	102	55	45	12	2
	5	□		-1080L-DIN	118	71	45	12	4
	5	●		-1080L-DIN-C	118	71	45	12	2
10.9	3	□		-1090S-DIN	102	55	45	12	4
	3	●		-1090S-DIN-C	102	55	45	12	2
	5	□		-1090L-DIN	118	71	45	12	4
	5	●		-1090L-DIN-C	118	71	45	12	2

Диам. сверла D1 (мм)	Глубина сверления (l/d)	Наличие		Обозначение	Размеры (мм)				Тип
		DP1021			L1	L3	L9	D4	
11.0	3	□		MPS1-1100S-DIN	102	55	45	12	4
	3	●		-1100S-DIN-C	102	55	45	12	2
	5	□		-1100L-DIN	118	71	45	12	4
	5	●		-1100L-DIN-C	118	71	45	12	2
11.1	3	□		-1110S-DIN	102	55	45	12	4
	3	●		-1110S-DIN-C	102	55	45	12	2
	5	□		-1110L-DIN	118	71	45	12	4
	5	●		-1110L-DIN-C	118	71	45	12	2
11.2	3	□		-1120S-DIN	102	55	45	12	4
	3	●		-1120S-DIN-C	102	55	45	12	2
	5	□		-1120L-DIN	118	71	45	12	4
	5	●		-1120L-DIN-C	118	71	45	12	2
11.3	3	□		-1130S-DIN	102	55	45	12	4
	3	●		-1130S-DIN-C	102	55	45	12	2
	5	□		-1130L-DIN	118	71	45	12	4
	5	●		-1130L-DIN-C	118	71	45	12	2
11.4	3	□		-1140S-DIN	102	55	45	12	4
	3	●		-1140S-DIN-C	102	55	45	12	2
	5	□		-1140L-DIN	118	71	45	12	4
	5	●		-1140L-DIN-C	118	71	45	12	2
11.5	3	□		-1150S-DIN	102	55	45	12	4
	3	●		-1150S-DIN-C	102	55	45	12	2
	5	□		-1150L-DIN	118	71	45	12	4
	5	●		-1150L-DIN-C	118	71	45	12	2
11.6	3	□		-1160S-DIN	102	55	45	12	4
	3	●		-1160S-DIN-C	102	55	45	12	2
	5	□		-1160L-DIN	118	71	45	12	4
	5	●		-1160L-DIN-C	118	71	45	12	2
11.7	3	□		-1170S-DIN	102	55	45	12	4
	3	●		-1170S-DIN-C	102	55	45	12	2
	5	□		-1170L-DIN	118	71	45	12	4
	5	●		-1170L-DIN-C	118	71	45	12	2
11.8	3	□		-1180S-DIN	102	55	45	12	4
	3	●		-1180S-DIN-C	102	55	45	12	2
	5	□		-1180L-DIN	118	71	45	12	4
	5	●		-1180L-DIN-C	118	71	45	12	2
11.9	3	□		-1190S-DIN	102	55	45	12	4
	3	●		-1190S-DIN-C	102	55	45	12	2
	5	□		-1190L-DIN	118	71	45	12	4
	5	●		-1190L-DIN-C	118	71	45	12	2
12.0	3	□		-1200S-DIN	102	55	45	12	4
	3	●		-1200S-DIN-C	102	55	45	12	2
	5	□		-1200L-DIN	118	71	45	12	4
	5	●		-1200L-DIN-C	118	71	45	12	2
12.05	3	□		-1205S-DIN	107	60	45	14	4
	3	●		-1205S-DIN-C	107	60	45	14	2
	5	□		-1205L-DIN	124	77	45	14	4
	5	●		-1205L-DIN-C	124	77	45	14	2
12.1	3	□		-1210S-DIN	107	60	45	14	4
	3	●		-1210S-DIN-C	107	60	45	14	2
	5	□		-1210L-DIN	124	77	45	14	4
	5	●		-1210L-DIN-C	124	77	45	14	2
12.2	3	□		-1220S-DIN	107	60	45	14	4
	3	●		-1220S-DIN-C	107	60	45	14	2
	5	□		-1220L-DIN	124	77	45	14	4
	5	●		-1220L-DIN-C	124	77	45	14	2

# СВЕРЛЕНИЕ (МОНОЛИТНЫЕ ТВЕРДОСПЛАВНЫЕ СВЕРЛА)

## MPS1

Тип с двойной ленточкой

ТВЕРДЫЙ  
СПЛАВ

СВЕРЛЕНИЕ

Диам. сверла D1 (мм)	Глубина сверления (l/d)	Наличие		Обозначение	Размеры (мм)				Тип
		DP1021			L1	L3	L9	D4	
12.3	3	<input type="checkbox"/>		MPS1-1230S-DIN	107	60	45	14	4
	3	<input checked="" type="checkbox"/>		-1230S-DIN-C	107	60	45	14	2
	5	<input type="checkbox"/>		-1230L-DIN	124	77	45	14	4
	5	<input checked="" type="checkbox"/>		-1230L-DIN-C	124	77	45	14	2
12.4	3	<input type="checkbox"/>		-1240S-DIN	107	60	45	14	4
	3	<input checked="" type="checkbox"/>		-1240S-DIN-C	107	60	45	14	2
	5	<input type="checkbox"/>		-1240L-DIN	124	77	45	14	4
	5	<input checked="" type="checkbox"/>		-1240L-DIN-C	124	77	45	14	2
12.5	3	<input type="checkbox"/>		-1250S-DIN	107	60	45	14	4
	3	<input checked="" type="checkbox"/>		-1250S-DIN-C	107	60	45	14	2
	5	<input type="checkbox"/>		-1250L-DIN	124	77	45	14	4
	5	<input checked="" type="checkbox"/>		-1250L-DIN-C	124	77	45	14	2
12.6	3	<input type="checkbox"/>		-1260S-DIN	107	60	45	14	4
	3	<input checked="" type="checkbox"/>		-1260S-DIN-C	107	60	45	14	2
	5	<input type="checkbox"/>		-1260L-DIN	124	77	45	14	4
	5	<input checked="" type="checkbox"/>		-1260L-DIN-C	124	77	45	14	2
12.7	3	<input type="checkbox"/>		-1270S-DIN	107	60	45	14	4
	3	<input checked="" type="checkbox"/>		-1270S-DIN-C	107	60	45	14	2
	5	<input type="checkbox"/>		-1270L-DIN	124	77	45	14	4
	5	<input checked="" type="checkbox"/>		-1270L-DIN-C	124	77	45	14	2
12.8	3	<input type="checkbox"/>		-1280S-DIN	107	60	45	14	4
	3	<input checked="" type="checkbox"/>		-1280S-DIN-C	107	60	45	14	2
	5	<input type="checkbox"/>		-1280L-DIN	124	77	45	14	4
	5	<input checked="" type="checkbox"/>		-1280L-DIN-C	124	77	45	14	2
12.9	3	<input type="checkbox"/>		-1290S-DIN	107	60	45	14	4
	3	<input checked="" type="checkbox"/>		-1290S-DIN-C	107	60	45	14	2
	5	<input type="checkbox"/>		-1290L-DIN	124	77	45	14	4
	5	<input checked="" type="checkbox"/>		-1290L-DIN-C	124	77	45	14	2
13.0	3	<input type="checkbox"/>		-1300S-DIN	107	60	45	14	4
	3	<input checked="" type="checkbox"/>		-1300S-DIN-C	107	60	45	14	2
	5	<input type="checkbox"/>		-1300L-DIN	124	77	45	14	4
	5	<input checked="" type="checkbox"/>		-1300L-DIN-C	124	77	45	14	2
13.1	3	<input type="checkbox"/>		-1310S-DIN	107	60	45	14	4
	3	<input checked="" type="checkbox"/>		-1310S-DIN-C	107	60	45	14	2
	5	<input type="checkbox"/>		-1310L-DIN	124	77	45	14	4
	5	<input checked="" type="checkbox"/>		-1310L-DIN-C	124	77	45	14	2
13.2	3	<input type="checkbox"/>		-1320S-DIN	107	60	45	14	4
	3	<input checked="" type="checkbox"/>		-1320S-DIN-C	107	60	45	14	2
	5	<input type="checkbox"/>		-1320L-DIN	124	77	45	14	4
	5	<input checked="" type="checkbox"/>		-1320L-DIN-C	124	77	45	14	2
13.3	3	<input type="checkbox"/>		-1330S-DIN	107	60	45	14	4
	3	<input checked="" type="checkbox"/>		-1330S-DIN-C	107	60	45	14	2
	5	<input type="checkbox"/>		-1330L-DIN	124	77	45	14	4
	5	<input checked="" type="checkbox"/>		-1330L-DIN-C	124	77	45	14	2
13.4	3	<input type="checkbox"/>		-1340S-DIN	107	60	45	14	4
	3	<input checked="" type="checkbox"/>		-1340S-DIN-C	107	60	45	14	2
	5	<input type="checkbox"/>		-1340L-DIN	124	77	45	14	4
	5	<input checked="" type="checkbox"/>		-1340L-DIN-C	124	77	45	14	2
13.5	3	<input type="checkbox"/>		-1350S-DIN	107	60	45	14	4
	3	<input checked="" type="checkbox"/>		-1350S-DIN-C	107	60	45	14	2
	5	<input type="checkbox"/>		-1350L-DIN	124	77	45	14	4
	5	<input checked="" type="checkbox"/>		-1350L-DIN-C	124	77	45	14	2
13.6	3	<input type="checkbox"/>		-1360S-DIN	107	60	45	14	4
	3	<input checked="" type="checkbox"/>		-1360S-DIN-C	107	60	45	14	2
	5	<input type="checkbox"/>		-1360L-DIN	124	77	45	14	4
	5	<input checked="" type="checkbox"/>		-1360L-DIN-C	124	77	45	14	2

Диам. сверла D1 (мм)	Глубина сверления (l/d)	Наличие		Обозначение	Размеры (мм)				Тип
		DP1021			L1	L3	L9	D4	
13.7	3	<input type="checkbox"/>		MPS1-1370S-DIN	107	60	45	14	4
	3	<input checked="" type="checkbox"/>		-1370S-DIN-C	107	60	45	14	2
	5	<input type="checkbox"/>		-1370L-DIN	124	77	45	14	4
	5	<input checked="" type="checkbox"/>		-1370L-DIN-C	124	77	45	14	2
13.8	3	<input type="checkbox"/>		-1380S-DIN	107	60	45	14	4
	3	<input checked="" type="checkbox"/>		-1380S-DIN-C	107	60	45	14	2
	5	<input type="checkbox"/>		-1380L-DIN	124	77	45	14	4
	5	<input checked="" type="checkbox"/>		-1380L-DIN-C	124	77	45	14	2
13.9	3	<input type="checkbox"/>		-1390S-DIN	107	60	45	14	4
	3	<input checked="" type="checkbox"/>		-1390S-DIN-C	107	60	45	14	2
	5	<input type="checkbox"/>		-1390L-DIN	124	77	45	14	4
	5	<input checked="" type="checkbox"/>		-1390L-DIN-C	124	77	45	14	2
14.0	3	<input type="checkbox"/>		-1400S-DIN	107	60	45	14	4
	3	<input checked="" type="checkbox"/>		-1400S-DIN-C	107	60	45	14	2
	5	<input type="checkbox"/>		-1400L-DIN	124	77	45	14	4
	5	<input checked="" type="checkbox"/>		-1400L-DIN-C	124	77	45	14	2
14.2	3	<input type="checkbox"/>		-1420S-DIN	114	64	48	16	4
	3	<input checked="" type="checkbox"/>		-1420S-DIN-C	114	64	48	16	2
	5	<input type="checkbox"/>		-1420L-DIN	132	82	48	16	4
	5	<input checked="" type="checkbox"/>		-1420L-DIN-C	132	82	48	16	2
14.5	3	<input type="checkbox"/>		-1450S-DIN	114	64	48	16	4
	3	<input checked="" type="checkbox"/>		-1450S-DIN-C	114	64	48	16	2
	5	<input type="checkbox"/>		-1450L-DIN	132	82	48	16	4
	5	<input checked="" type="checkbox"/>		-1450L-DIN-C	132	82	48	16	2
15.0	3	<input type="checkbox"/>		-1500S-DIN	114	64	48	16	4
	3	<input checked="" type="checkbox"/>		-1500S-DIN-C	114	64	48	16	2
	5	<input type="checkbox"/>		-1500L-DIN	132	82	48	16	4
	5	<input checked="" type="checkbox"/>		-1500L-DIN-C	132	82	48	16	2
15.5	3	<input type="checkbox"/>		-1550S-DIN	115	65	48	16	4
	3	<input checked="" type="checkbox"/>		-1550S-DIN-C	115	65	48	16	2
	5	<input type="checkbox"/>		-1550L-DIN	133	83	48	16	4
	5	<input checked="" type="checkbox"/>		-1550L-DIN-C	133	83	48	16	2
16.0	3	<input type="checkbox"/>		-1600S-DIN	115	65	48	16	4
	3	<input checked="" type="checkbox"/>		-1600S-DIN-C	115	65	48	16	2
	5	<input type="checkbox"/>		-1600L-DIN	133	83	48	16	4
	5	<input checked="" type="checkbox"/>		-1600L-DIN-C	133	83	48	16	2
16.5	3	<input type="checkbox"/>		-1650S-DIN	123	73	48	18	4
	3	<input checked="" type="checkbox"/>		-1650S-DIN-C	123	73	48	18	2
	5	<input type="checkbox"/>		-1650L-DIN	143	93	48	18	4
	5	<input checked="" type="checkbox"/>		-1650L-DIN-C	143	93	48	18	2
17.0	3	<input type="checkbox"/>		-1700S-DIN	123	73	48	18	4
	3	<input checked="" type="checkbox"/>		-1700S-DIN-C	123	73	48	18	2
	5	<input type="checkbox"/>		-1700L-DIN	143	93	48	18	4
	5	<input checked="" type="checkbox"/>		-1700L-DIN-C	143	93	48	18	2
17.5	3	<input type="checkbox"/>		-1750S-DIN	123	73	48	18	4
	3	<input checked="" type="checkbox"/>		-1750S-DIN-C	123	73	48	18	2
	5	<input type="checkbox"/>		-1750L-DIN	143	93	48	18	4
	5	<input checked="" type="checkbox"/>		-1750L-DIN-C	143	93	48	18	2
18.0	3	<input type="checkbox"/>		-1800S-DIN	123	73	48	18	4
	3	<input checked="" type="checkbox"/>		-1800S-DIN-C	123	73	48	18	2
	5	<input type="checkbox"/>		-1800L-DIN	143	93	48	18	4
	5	<input checked="" type="checkbox"/>		-1800L-DIN-C	143	93	48	18	2
18.5	3	<input type="checkbox"/>		-1850S-DIN	131	79	50	20	4
	3	<input checked="" type="checkbox"/>		-1850S-DIN-C	131	79	50	20	2
	5	<input type="checkbox"/>		-1850L-DIN	153	101	50	20	4
	5	<input checked="" type="checkbox"/>		-1850L-DIN-C	153	101	50	20	2

● : Есть на складе. □ : Нет на складе, выпускается исключительно под заказ.

Диам. сверла D1 (мм)	Глубина сверления (l/d)	Наличие		Обозначение	Размеры (мм)				Тип
		DP1021			L1	L3	L9	D4	
19.0	3	<input type="checkbox"/>		MPS1-1900S-DIN	131	79	50	20	4
	3	<input checked="" type="checkbox"/>		-1900S-DIN-C	131	79	50	20	2
	5	<input type="checkbox"/>		-1900L-DIN	153	101	50	20	4
	5	<input checked="" type="checkbox"/>		-1900L-DIN-C	153	101	50	20	2
19.5	3	<input type="checkbox"/>		-1950S-DIN	131	79	50	20	4
	3	<input checked="" type="checkbox"/>		-1950S-DIN-C	131	79	50	20	2
	5	<input type="checkbox"/>		-1950L-DIN	153	101	50	20	4
	5	<input checked="" type="checkbox"/>		-1950L-DIN-C	153	101	50	20	2
20.0	3	<input type="checkbox"/>		-2000S-DIN	131	79	50	20	4
	3	<input checked="" type="checkbox"/>		-2000S-DIN-C	131	79	50	20	2
	5	<input type="checkbox"/>		-2000L-DIN	153	101	50	20	4
	5	<input checked="" type="checkbox"/>		-2000L-DIN-C	153	101	50	20	2

## РЕКОМЕНДУЕМЫЕ РЕЖИМЫ РЕЗАНИЯ

### ● MPS1 СВЕРЛА (3xD, 5xD)

Обрабатываемый материал	Диаметр сверла	φ3		φ4		φ5		
		Условия	Скорость резания (м/мин)	Подача (мм/об)	Скорость резания (м/мин)	Подача (мм/об)	Скорость резания (м/мин)	Подача (мм/об)
		Твердость						
<b>P</b> Малоуглеродистые стали	≤180НВ	100 (60–150)	0.15 (0.1–0.2)	120 (70–170)	0.19 (0.12–0.25)	130 (80–190)	0.23 (0.15–0.3)	
	180–250НВ	90 (60–140)	0.15 (0.1–0.19)	100 (70–160)	0.18 (0.12–0.24)	110 (80–180)	0.22 (0.15–0.29)	
	280–350НВ	80 (50–110)	0.12 (0.1–0.14)	90 (60–120)	0.15 (0.12–0.18)	90 (70–140)	0.19 (0.15–0.22)	
<b>M</b> Легированная сталь	–	40 (20–50)	0.08 (0.06–0.12)	40 (30–50)	0.09 (0.07–0.13)	40 (30–50)	0.11 (0.08–0.16)	
<b>K</b> Нержавеющая сталь	≤350МПа	90 (60–100)	0.15 (0.1–0.2)	100 (70–110)	0.21 (0.12–0.3)	110 (80–130)	0.25 (0.15–0.35)	
	≤450МПа	80 (50–90)	0.12 (0.08–0.16)	90 (60–100)	0.17 (0.1–0.24)	90 (70–120)	0.21 (0.14–0.28)	
	≤800МПа	60 (40–80)	0.09 (0.06–0.12)	70 (50–90)	0.13 (0.08–0.18)	70 (60–100)	0.17 (0.12–0.22)	

Обрабатываемый материал	Диаметр сверла	φ6		φ8		φ10		
		Условия	Скорость резания (м/мин)	Подача (мм/об)	Скорость резания (м/мин)	Подача (мм/об)	Скорость резания (м/мин)	Подача (мм/об)
		Твердость						
<b>P</b> Малоуглеродистые стали	≤180НВ	140 (90–210)	0.27 (0.18–0.35)	160 (100–240)	0.3 (0.2–0.4)	170 (100–250)	0.33 (0.2–0.45)	
	180–250НВ	120 (90–190)	0.26 (0.18–0.33)	140 (100–220)	0.29 (0.2–0.38)	150 (100–230)	0.32 (0.2–0.43)	
	280–350НВ	100 (80–150)	0.22 (0.18–0.25)	120 (90–170)	0.24 (0.2–0.27)	130 (90–180)	0.25 (0.2–0.3)	
<b>M</b> Легированная сталь	–	50 (40–70)	0.14 (0.11–0.18)	50 (40–70)	0.15 (0.12–0.2)	50 (40–70)	0.16 (0.12–0.22)	
<b>K</b> Нержавеющая сталь	≤350МПа	120 (90–140)	0.29 (0.18–0.4)	140 (100–160)	0.33 (0.2–0.45)	150 (100–170)	0.35 (0.2–0.5)	
	≤450МПа	100 (80–130)	0.25 (0.16–0.34)	120 (90–150)	0.28 (0.18–0.38)	130 (90–160)	0.29 (0.18–0.4)	
	≤800МПа	80 (70–110)	0.2 (0.14–0.26)	100 (80–130)	0.23 (0.16–0.3)	110 (80–140)	0.24 (0.16–0.32)	

Обрабатываемый материал	Диаметр сверла	φ12		φ16		φ20		
		Условия	Скорость резания (м/мин)	Подача (мм/об)	Скорость резания (м/мин)	Подача (мм/об)	Скорость резания (м/мин)	Подача (мм/об)
		Твердость						
<b>P</b> Малоуглеродистые стали	≤180НВ	180 (100–250)	0.35 (0.2–0.5)	180 (100–250)	0.38 (0.2–0.55)	180 (100–250)	0.4 (0.2–0.6)	
	180–250НВ	160 (100–230)	0.34 (0.2–0.48)	160 (100–230)	0.36 (0.2–0.52)	160 (100–230)	0.39 (0.2–0.57)	
	280–350НВ	140 (90–180)	0.27 (0.2–0.34)	140 (90–180)	0.28 (0.2–0.36)	140 (90–180)	0.3 (0.2–0.4)	
<b>M</b> Легированная сталь	–	50 (40–70)	0.18 (0.14–0.24)	50 (40–70)	0.19 (0.15–0.26)	50 (40–70)	0.21 (0.16–0.28)	
<b>K</b> Нержавеющая сталь	≤350МПа	160 (100–170)	0.4 (0.2–0.6)	160 (100–170)	0.43 (0.2–0.65)	160 (100–170)	0.45 (0.2–0.7)	
	≤450МПа	140 (90–160)	0.31 (0.18–0.44)	140 (90–160)	0.33 (0.18–0.48)	140 (90–160)	0.35 (0.18–0.52)	
	≤800МПа	110 (80–140)	0.25 (0.16–0.34)	110 (80–140)	0.27 (0.16–0.38)	110 (80–140)	0.28 (0.16–0.4)	

## MPS1

Тип с двойной ленточкой

### ИНСТРУКЦИЯ ПО ЭКСПЛУАТАЦИИ

<p><b>Крепление сверла</b></p> <p>Регулируемый винт</p> <p>Цанговый патрон с упорным подшипником надежно держит сверло.</p>	<p><b>Длина сверла</b></p> <p><math>A \geq D1 \times 1.5</math></p>	<p><b>Установка сверла</b></p> <p>Не прижимать по режущей кромке.</p>	<p><b>Допуск на установку</b></p> <p>Биение <math>\leq 0.03\text{мм}</math></p>
<p><b>Тип охлаждения через сквозные отверстия</b></p> <p>Тип охлаждения через шпиндель</p> <p>Тип охлаждения на вращающийся шпиндель станка</p> <p>Давление СОЖ приблизительно 0.5—1МПа (<math>&lt; \phi 5: 2-3\text{МПа}</math>). Расход СОЖ 1.5—4 мин.</p>	<p><b>Рекомендации по использованию СОЖ</b></p> <ol style="list-style-type: none"> <li>1) Мелкая металлическая стружка забивается в отверстие для подачи СОЖ в сверлах малого диаметра. Для предотвращения этого процесса обязательно используйте мелкий сетчатый фильтр.</li> <li>2) Частицы грязи и пыли прилипают к маслу в составе СОЖ и препятствуют эффективной подаче СОЖ. Рекомендуется регулярно менять СОЖ.</li> </ol>	<p><b>Тонкая заготовка</b></p> <p>Если наблюдается отгиб.</p> <p>Необходима опора для заготовки.</p>	<p><b>Прерывистое резание</b></p> <p>Один процесс</p> <p>① Уменьшить подачу при сверлении разогнутой детали (при прерывистом сверлении).</p> <p>Требуется предварительная обработка.</p> <p>① До сверления предварительно подрезать торец концевой фрезой.</p>
<p><b>Ступенчатые отверстия.</b></p> <ol style="list-style-type: none"> <li>① Разделите два указанных процесса.</li> <li>② Сначала просверлите отверстие большего диаметра.</li> </ol> <p>*Инструмент, применимый как для снятия фаски, так и для подрезки торца, может быть изготовлен на заказ.</p>	<p><b>Образование заусенцев и выкрашивание заготовки.</b></p> <ol style="list-style-type: none"> <li>① Снизить скорость подачи на 50% в конце сквозной обработки.</li> <li>② Добавить фаску 45°</li> <li>③ Измените угол при вершине.</li> </ol>		

- Глубина сверления 3-40 l/d.
- Тип MPS с двойной ленточкой для точного и надежного сверления.
- Все сверла имеют отверстия для внутреннего охлаждения.



Углеродистая сталь Легированная сталь	Закалённая сталь	Нержавеющая сталь	Чугун	Лёгкий сплав	Жаропрочные сплавы
○		○	○	○	○



### ● Тип 1 Цилиндрический хвостовик



MPS----S/L-DIN-C (l/d 3—5)

MPS----L (l/d 8—40)

Диам. сверла D1 (мм)	Глубина сверления (l/d)	Наличие VP15TF	Обозначение	Размеры (мм)				Тип
				L1	L3	L9	D4	
3.0	3	●	MPS0300S-DIN	62	20	36	6	2
	3	●	MPS0300S-DIN-C	62	20	36	6	1
	5	●	MPS0300L-DIN	66	28	36	6	2
	5	●	MPS0300L-DIN-C	66	28	36	6	1
	8	●	MPS0300-L8C	74	34	36	6	1
	10	●	MPS0300-L10C	80	40	36	6	1
	12	●	MPS0300-L12C	86	46	36	6	1
	15	●	MPS0300-L15C	95	55	36	6	1
	20	●	MPS0300-L20C	110	70	36	6	1
	25	●	MPS0300-L25C	125	85	36	6	1
	30	●	MPS0300-L30C	140	100	36	6	1
	35	□	MPS0300-L35C	159	116	36	6	1
40	●	MPS0300-L40C	174	131	36	6	1	
3.05	3	●	MPS0305S-DIN	62	20	36	6	2
	3	●	MPS0305S-DIN-C	62	20	36	6	1
	5	●	MPS0305L-DIN	66	28	36	6	2
	5	●	MPS0305L-DIN-C	66	28	36	6	1
3.1	3	●	MPS0310S-DIN	62	20	36	6	2
	3	●	MPS0310S-DIN-C	62	20	36	6	1
	5	●	MPS0310L-DIN	66	28	36	6	2
	5	●	MPS0310L-DIN-C	66	28	36	6	1
	8	●	MPS0310-L8C	80	40	36	6	1
	10	□	MPS0310-L10C	87	47	36	6	1
	12	●	MPS0310-L12C	94	54	36	6	1
	15	●	MPS0310-L15C	104	64	36	6	1
	20	□	MPS0310-L20C	122	82	36	6	1
	25	□	MPS0310-L25C	139	99	36	6	1
	30	□	MPS0310-L30C	157	117	36	6	1
	35	□	MPS0310-L35C	176	126	36	6	1
40	□	MPS0310-L40C	191	141	36	6	1	
3.2	3	●	MPS0320S-DIN	62	20	36	6	2
	3	●	MPS0320S-DIN-C	62	20	36	6	1
	5	●	MPS0320L-DIN	66	28	36	6	2
	5	●	MPS0320L-DIN-C	66	28	36	6	1
	8	●	MPS0320-L8C	80	40	36	6	1
	10	□	MPS0320-L10C	87	47	36	6	1
	12	●	MPS0320-L12C	94	54	36	6	1
	15	●	MPS0320-L15C	104	64	36	6	1
	20	□	MPS0320-L20C	122	82	36	6	1
	25	□	MPS0320-L25C	139	99	36	6	1
	30	□	MPS0320-L30C	157	117	36	6	1
	40	□	MPS0320-L40C	191	151	36	6	1

### ● Тип 2 Хвостовик с лыской

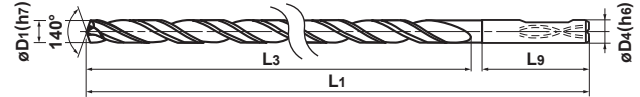

MPS----S/L-DIN (l/d 3—5)

Диам. сверла D1 (мм)	Глубина сверления (l/d)	Наличие VP15TF	Обозначение	Размеры (мм)				Тип
				L1	L3	L9	D4	
3.2	35	□	MPS0320-L35C	176	126	36	6	1
	40	□	MPS0320-L40C	191	141	36	6	1
3.3	3	●	MPS0330S-DIN	62	20	36	6	2
	3	●	MPS0330S-DIN-C	62	20	36	6	1
	5	●	MPS0330L-DIN	66	28	36	6	2
	5	●	MPS0330L-DIN-C	66	28	36	6	1
	8	●	MPS0330-L8C	80	40	36	6	1
	10	□	MPS0330-L10C	87	47	36	6	1
	12	●	MPS0330-L12C	94	54	36	6	1
	15	●	MPS0330-L15C	104	64	36	6	1
	20	□	MPS0330-L20C	122	82	36	6	1
	25	□	MPS0330-L25C	139	99	36	6	1
	30	●	MPS0330-L30C	157	117	36	6	1
	35	□	MPS0330-L35C	176	135	36	6	1
40	□	MPS0330-L40C	191	151	36	6	1	
3.4	3	●	MPS0340S-DIN	62	20	36	6	2
	3	●	MPS0340S-DIN-C	62	20	36	6	1
	5	●	MPS0340L-DIN	66	28	36	6	2
	5	●	MPS0340L-DIN-C	66	28	36	6	1
	8	●	MPS0340-L8C	80	40	36	6	1
	10	□	MPS0340-L10C	87	47	36	6	1
	12	●	MPS0340-L12C	94	54	36	6	1
	15	●	MPS0340-L15C	104	64	36	6	1
	20	□	MPS0340-L20C	122	82	36	6	1
	25	□	MPS0340-L25C	139	99	36	6	1
	30	□	MPS0340-L30C	157	117	36	6	1
	35	□	MPS0340-L35C	176	135	36	6	1
40	□	MPS0340-L40C	191	151	36	6	1	
3.5	3	●	MPS0350S-DIN	62	20	36	6	2
	3	●	MPS0350S-DIN-C	62	20	36	6	1
	5	●	MPS0350L-DIN	66	28	36	6	2
	5	●	MPS0350L-DIN-C	66	28	36	6	1
	8	●	MPS0350-L8C	80	40	36	6	1
	10	□	MPS0350-L10C	87	47	36	6	1
	12	●	MPS0350-L12C	94	54	36	6	1
	15	●	MPS0350-L15C	104	64	36	6	1
	20	●	MPS0350-L20C	122	82	36	6	1
	25	□	MPS0350-L25C	139	99	36	6	1
	30	□	MPS0350-L30C	157	117	36	6	1
	35	□	MPS0350-L35C	176	135	36	6	1
40	●	MPS0350-L40C	191	151	36	6	1	

● : Есть на складе. □ : Нет на складе, выпускается исключительно под заказ.

РЕЖИМЫ РЕЗАНИЯ > L053  
ТЕХНИЧЕСКИЕ ДАННЫЕ > N001

# СВЕРЛЕНИЕ (МОНОЛИТНЫЕ ТВЕРДОСПЛАВНЫЕ СВЕРЛА)

## MPS

Тип с двойной ленточкой

ТВЕРДЫЙ  
СПЛАВ

СВЕРЛЕНИЕ

Диам. сверла D1 (мм)	Глубина сверления (l/d)	Наличие VP15TF	Обозначение	Размеры (мм)				Тип
				L1	L3	L9	D4	
3.6	3	●	MPS0360S-DIN	62	20	36	6	2
	3	●	MPS0360S-DIN-C	62	20	36	6	1
	5	●	MPS0360L-DIN	66	28	36	6	2
	5	●	MPS0360L-DIN-C	66	28	36	6	1
	8	●	MPS0360-L8C	85	45	36	6	1
	10	□	MPS0360-L10C	93	53	36	6	1
	12	●	MPS0360-L12C	101	61	36	6	1
	15	●	MPS0360-L15C	113	73	36	6	1
	20	□	MPS0360-L20C	133	93	36	6	1
	25	□	MPS0360-L25C	153	113	36	6	1
	30	□	MPS0360-L30C	173	133	36	6	1
	35	□	MPS0360-L35C	193	146	36	6	1
40	□	MPS0360-L40C	213	163	36	6	1	
3.7	3	●	MPS0370S-DIN	62	20	36	6	2
	3	●	MPS0370S-DIN-C	62	20	36	6	1
	5	●	MPS0370L-DIN	66	28	36	6	2
	5	●	MPS0370L-DIN-C	66	28	36	6	1
	8	●	MPS0370-L8C	85	45	36	6	1
	10	□	MPS0370-L10C	93	53	36	6	1
	12	●	MPS0370-L12C	101	61	36	6	1
	15	●	MPS0370-L15C	113	73	36	6	1
	20	□	MPS0370-L20C	133	93	36	6	1
	25	□	MPS0370-L25C	153	113	36	6	1
	30	□	MPS0370-L30C	173	133	36	6	1
	35	□	MPS0370-L35C	193	146	36	6	1
40	□	MPS0370-L40C	213	163	36	6	1	
3.8	3	●	MPS0380S-DIN	66	24	36	6	2
	3	●	MPS0380S-DIN-C	66	24	36	6	1
	5	●	MPS0380L-DIN	74	36	36	6	2
	5	●	MPS0380L-DIN-C	74	36	36	6	1
	8	●	MPS0380-L8C	85	45	36	6	1
	10	□	MPS0380-L10C	93	53	36	6	1
	12	●	MPS0380-L12C	101	61	36	6	1
	15	●	MPS0380-L15C	113	73	36	6	1
	20	□	MPS0380-L20C	133	93	36	6	1
	25	□	MPS0380-L25C	153	113	36	6	1
	30	□	MPS0380-L30C	173	133	36	6	1
	35	□	MPS0380-L35C	193	153	36	6	1
40	□	MPS0380-L40C	213	173	36	6	1	
3.9	3	●	MPS0390S-DIN	66	24	36	6	2
	3	●	MPS0390S-DIN-C	66	24	36	6	1
	5	●	MPS0390L-DIN	74	36	36	6	2
	5	●	MPS0390L-DIN-C	74	36	36	6	1
	8	●	MPS0390-L8C	85	45	36	6	1
	10	□	MPS0390-L10C	93	53	36	6	1
	12	●	MPS0390-L12C	101	61	36	6	1
	15	●	MPS0390-L15C	113	73	36	6	1
	20	□	MPS0390-L20C	133	93	36	6	1
	25	□	MPS0390-L25C	153	113	36	6	1
	30	□	MPS0390-L30C	173	133	36	6	1
	35	□	MPS0390-L35C	193	153	36	6	1
40	□	MPS0390-L40C	213	173	36	6	1	
4.0	3	●	MPS0400S-DIN	66	24	36	6	2
	3	●	MPS0400S-DIN-C	66	24	36	6	1

Диам. сверла D1 (мм)	Глубина сверления (l/d)	Наличие VP15TF	Обозначение	Размеры (мм)				Тип
				L1	L3	L9	D4	
4.0	5	●	MPS0400L-DIN	74	36	36	6	2
	5	●	MPS0400L-DIN-C	74	36	36	6	1
	8	●	MPS0400-L8C	85	45	36	6	1
	10	●	MPS0400-L10C	93	53	36	6	1
	12	●	MPS0400-L12C	101	61	36	6	1
	15	●	MPS0400-L15C	113	73	36	6	1
	20	●	MPS0400-L20C	133	93	36	6	1
	25	●	MPS0400-L25C	153	113	36	6	1
	30	●	MPS0400-L30C	173	133	36	6	1
	35	□	MPS0400-L35C	193	153	36	6	1
	40	●	MPS0400-L40C	213	173	36	6	1
	4.05	3	●	MPS0405S-DIN	66	24	36	6
3		●	MPS0405S-DIN-C	66	24	36	6	1
5		●	MPS0405L-DIN	74	36	36	6	2
5		●	MPS0405L-DIN-C	74	36	36	6	1
4.1	3	●	MPS0410S-DIN	66	24	36	6	2
	3	●	MPS0410S-DIN-C	66	24	36	6	1
	5	●	MPS0410L-DIN	74	36	36	6	2
	5	●	MPS0410L-DIN-C	74	36	36	6	1
	8	●	MPS0410-L8C	91	51	36	6	1
	10	□	MPS0410-L10C	100	60	36	6	1
	12	●	MPS0410-L12C	109	69	36	6	1
	15	●	MPS0410-L15C	122	82	36	6	1
	20	□	MPS0410-L20C	145	105	36	6	1
	25	□	MPS0410-L25C	167	127	36	6	1
	30	□	MPS0410-L30C	190	150	36	6	1
	35	□	MPS0410-L35C	212	166	36	6	1
40	□	MPS0410-L40C	236	186	36	6	1	
4.2	3	●	MPS0420S-DIN	66	24	36	6	2
	3	●	MPS0420S-DIN-C	66	24	36	6	1
	5	●	MPS0420L-DIN	74	36	36	6	2
	5	●	MPS0420L-DIN-C	74	36	36	6	1
	8	●	MPS0420-L8C	91	51	36	6	1
	10	□	MPS0420-L10C	100	60	36	6	1
	12	●	MPS0420-L12C	109	69	36	6	1
	15	●	MPS0420-L15C	122	82	36	6	1
	20	□	MPS0420-L20C	145	105	36	6	1
	25	□	MPS0420-L25C	167	127	36	6	1
	30	□	MPS0420-L30C	190	150	36	6	1
	35	●	MPS0420-L35C	212	166	36	6	1
40	●	MPS0420-L40C	236	186	36	6	1	
4.3	3	●	MPS0430S-DIN	66	24	36	6	2
	3	●	MPS0430S-DIN-C	66	24	36	6	1
	5	●	MPS0430L-DIN	74	36	36	6	2
	5	●	MPS0430L-DIN-C	74	36	36	6	1
	8	●	MPS0430-L8C	91	51	36	6	1
	10	□	MPS0430-L10C	100	60	36	6	1
	12	●	MPS0430-L12C	109	69	36	6	1
	15	●	MPS0430-L15C	122	82	36	6	1
	20	□	MPS0430-L20C	145	105	36	6	1
	25	□	MPS0430-L25C	167	127	36	6	1
	30	□	MPS0430-L30C	190	150	36	6	1
	35	□	MPS0430-L35C	212	172	36	6	1
40	□	MPS0430-L40C	236	196	36	6	1	

● : Есть на складе. □ : Нет на складе, выпускается исключительно под заказ.

Диам. сверла D1 (мм)	Глубина сверления (l/d)	Наличие		Обозначение	Размеры (мм)				Тип
		VP15TF			L1	L3	L9	D4	
4.4	3	●		MPS0440S-DIN	66	24	36	6	2
	3	●		MPS0440S-DIN-C	66	24	36	6	1
	5	●		MPS0440L-DIN	74	36	36	6	2
	5	●		MPS0440L-DIN-C	74	36	36	6	1
	8	●		MPS0440-L8C	91	51	36	6	1
	10	□		MPS0440-L10C	100	60	36	6	1
	12	●		MPS0440-L12C	109	69	36	6	1
	15	●		MPS0440-L15C	122	82	36	6	1
	20	□		MPS0440-L20C	145	105	36	6	1
	25	□		MPS0440-L25C	167	127	36	6	1
	30	□		MPS0440-L30C	190	150	36	6	1
	35	□		MPS0440-L35C	212	172	36	6	1
40	□		MPS0440-L40C	236	196	36	6	1	
4.5	3	●		MPS0450S-DIN	66	24	36	6	2
	3	●		MPS0450S-DIN-C	66	24	36	6	1
	5	●		MPS0450L-DIN	74	36	36	6	2
	5	●		MPS0450L-DIN-C	74	36	36	6	1
	8	●		MPS0450-L8C	91	51	36	6	1
	10	□		MPS0450-L10C	100	60	36	6	1
	12	●		MPS0450-L12C	109	69	36	6	1
	15	●		MPS0450-L15C	122	82	36	6	1
	20	□		MPS0450-L20C	145	105	36	6	1
	25	□		MPS0450-L25C	167	127	36	6	1
	30	□		MPS0450-L30C	190	150	36	6	1
	35	□		MPS0450-L35C	212	172	36	6	1
40	●		MPS0450-L40C	236	196	36	6	1	
4.6	3	●		MPS0460S-DIN	66	24	36	6	2
	3	●		MPS0460S-DIN-C	66	24	36	6	1
	5	●		MPS0460L-DIN	74	36	36	6	2
	5	●		MPS0460L-DIN-C	74	36	36	6	1
	8	●		MPS0460-L8C	96	55	36	6	1
	10	□		MPS0460-L10C	106	66	36	6	1
	12	●		MPS0460-L12C	116	76	36	6	1
	15	●		MPS0460-L15C	131	91	36	6	1
	20	□		MPS0460-L20C	156	116	36	6	1
	25	□		MPS0460-L25C	181	141	36	6	1
	30	□		MPS0460-L30C	206	166	36	6	1
	35	□		MPS0460-L35C	230	185	36	6	1
40	□		MPS0460-L40C	255	205	36	6	1	
4.65	3	●		MPS0465S-DIN	66	24	36	6	2
	3	●		MPS0465S-DIN-C	66	24	36	6	1
	5	●		MPS0465L-DIN	74	36	36	6	2
	5	●		MPS0465L-DIN-C	74	36	36	6	1
4.7	3	●		MPS0470S-DIN	66	24	36	6	2
	3	●		MPS0470S-DIN-C	66	24	36	6	1
	5	●		MPS0470L-DIN	74	36	36	6	2
	5	●		MPS0470L-DIN-C	74	36	36	6	1
	8	●		MPS0470-L8C	96	55	36	6	1
	10	□		MPS0470-L10C	106	66	36	6	1
	12	●		MPS0470-L12C	116	76	36	6	1
	15	●		MPS0470-L15C	131	91	36	6	1
	20	□		MPS0470-L20C	156	116	36	6	1
	25	□		MPS0470-L25C	181	141	36	6	1
	30	□		MPS0470-L30C	206	166	36	6	1
	35	□		MPS0470-L35C	230	185	36	6	1
40	□		MPS0470-L40C	255	205	36	6	1	

Диам. сверла D1 (мм)	Глубина сверления (l/d)	Наличие		Обозначение	Размеры (мм)				Тип
		VP15TF			L1	L3	L9	D4	
4.8	3	●		MPS0480S-DIN	66	28	36	6	2
	3	●		MPS0480S-DIN-C	66	28	36	6	1
	5	●		MPS0480L-DIN	82	44	36	6	2
	5	●		MPS0480L-DIN-C	82	44	36	6	1
	8	●		MPS0480-L8C	96	55	36	6	1
	10	□		MPS0480-L10C	106	66	36	6	1
	12	●		MPS0480-L12C	116	76	36	6	1
	15	●		MPS0480-L15C	131	91	36	6	1
	20	□		MPS0480-L20C	156	116	36	6	1
	25	□		MPS0480-L25C	181	141	36	6	1
	30	□		MPS0480-L30C	206	166	36	6	1
	35	□		MPS0480-L35C	230	191	36	6	1
40	□		MPS0480-L40C	255	216	36	6	1	
4.9	3	●		MPS0490S-DIN	66	28	36	6	2
	3	●		MPS0490S-DIN-C	66	28	36	6	1
	5	●		MPS0490L-DIN	82	44	36	6	2
	5	●		MPS0490L-DIN-C	82	44	36	6	1
	8	●		MPS0490-L8C	96	55	36	6	1
	10	□		MPS0490-L10C	106	66	36	6	1
	12	●		MPS0490-L12C	116	76	36	6	1
	15	●		MPS0490-L15C	131	91	36	6	1
	20	□		MPS0490-L20C	156	116	36	6	1
	25	□		MPS0490-L25C	181	141	36	6	1
	30	□		MPS0490-L30C	206	166	36	6	1
	35	□		MPS0490-L35C	230	191	36	6	1
40	□		MPS0490-L40C	255	216	36	6	1	
5.0	3	●		MPS0500S-DIN	66	28	36	6	2
	3	●		MPS0500S-DIN-C	66	28	36	6	1
	5	●		MPS0500L-DIN	82	44	36	6	2
	5	●		MPS0500L-DIN-C	82	44	36	6	1
	8	●		MPS0500-L8C	96	55	36	6	1
	10	●		MPS0500-L10C	106	66	36	6	1
	12	●		MPS0500-L12C	116	76	36	6	1
	15	●		MPS0500-L15C	131	91	36	6	1
	20	●		MPS0500-L20C	156	116	36	6	1
	25	●		MPS0500-L25C	181	141	36	6	1
	30	●		MPS0500-L30C	206	166	36	6	1
	35	□		MPS0500-L35C	230	191	36	6	1
40	●		MPS0500-L40C	255	216	36	6	1	
5.05	3	●		MPS0505S-DIN	66	28	36	6	2
	3	●		MPS0505S-DIN-C	66	28	36	6	1
	5	●		MPS0505L-DIN	82	44	36	6	2
	5	●		MPS0505L-DIN-C	82	44	36	6	1
5.1	3	●		MPS0510S-DIN	66	28	36	6	2
	3	●		MPS0510S-DIN-C	66	28	36	6	1
	5	●		MPS0510L-DIN	82	44	36	6	2
	5	●		MPS0510L-DIN-C	82	44	36	6	1
	8	●		MPS0510-L8C	102	62	36	6	1
	10	□		MPS0510-L10C	113	73	36	6	1
	12	●		MPS0510-L12C	124	84	36	6	1
	15	●		MPS0510-L15C	140	100	36	6	1
	20	□		MPS0510-L20C	168	128	36	6	1
	25	□		MPS0510-L25C	195	155	36	6	1
	30	□		MPS0510-L30C	223	183	36	6	1
	35	□		MPS0510-L35C	249	204	36	6	1
40	□		MPS0510-L40C	279	231	36	6	1	

# СВЕРЛЕНИЕ (МОНОЛИТНЫЕ ТВЕРДОСПЛАВНЫЕ СВЕРЛА)

## MPS

Тип с двойной ленточкой

ТВЕРДЫЙ  
СПЛАВ

СВЕРЛЕНИЕ

Диам. сверла D1 (мм)	Глубина сверления (l/d)	Наличие VP15TF	Обозначение	Размеры (мм)				Тип
				L1	L3	L9	D4	
5.2	3	●	MPS0520S-DIN	66	28	36	6	2
	3	●	MPS0520S-DIN-C	66	28	36	6	1
	5	●	MPS0520L-DIN	82	44	36	6	2
	5	●	MPS0520L-DIN-C	82	44	36	6	1
	8	●	MPS0520-L8C	102	62	36	6	1
	10	□	MPS0520-L10C	113	73	36	6	1
	12	●	MPS0520-L12C	124	84	36	6	1
	15	●	MPS0520-L15C	140	100	36	6	1
	20	□	MPS0520-L20C	168	128	36	6	1
	25	□	MPS0520-L25C	195	155	36	6	1
	30	□	MPS0520-L30C	223	183	36	6	1
	35	□	MPS0520-L35C	249	204	36	6	1
40	□	MPS0520-L40C	279	231	36	6	1	
5.3	3	●	MPS0530S-DIN	66	28	36	6	2
	3	●	MPS0530S-DIN-C	66	28	36	6	1
	5	●	MPS0530L-DIN	82	44	36	6	2
	5	●	MPS0530L-DIN-C	82	44	36	6	1
	8	●	MPS0530-L8C	102	62	36	6	1
	10	□	MPS0530-L10C	113	73	36	6	1
	12	●	MPS0530-L12C	124	84	36	6	1
	15	●	MPS0530-L15C	140	100	36	6	1
	20	□	MPS0530-L20C	168	128	36	6	1
	25	□	MPS0530-L25C	195	155	36	6	1
	30	□	MPS0530-L30C	223	183	36	6	1
	35	□	MPS0530-L35C	249	210	36	6	1
40	□	MPS0530-L40C	279	241	36	6	1	
5.4	3	●	MPS0540S-DIN	66	28	36	6	2
	3	●	MPS0540S-DIN-C	66	28	36	6	1
	5	●	MPS0540L-DIN	82	44	36	6	2
	5	●	MPS0540L-DIN-C	82	44	36	6	1
	8	●	MPS0540-L8C	102	62	36	6	1
	10	□	MPS0540-L10C	113	73	36	6	1
	12	●	MPS0540-L12C	124	84	36	6	1
	15	●	MPS0540-L15C	140	100	36	6	1
	20	□	MPS0540-L20C	168	128	36	6	1
	25	□	MPS0540-L25C	195	155	36	6	1
	30	□	MPS0540-L30C	223	183	36	6	1
	35	□	MPS0540-L35C	249	210	36	6	1
40	□	MPS0540-L40C	279	241	36	6	1	
5.5	3	●	MPS0550S-DIN	66	28	36	6	2
	3	●	MPS0550S-DIN-C	66	28	36	6	1
	5	●	MPS0550L-DIN	82	44	36	6	2
	5	●	MPS0550L-DIN-C	82	44	36	6	1
	8	●	MPS0550-L8C	102	62	36	6	1
	10	□	MPS0550-L10C	113	73	36	6	1
	12	●	MPS0550-L12C	124	84	36	6	1
	15	●	MPS0550-L15C	140	100	36	6	1
	20	□	MPS0550-L20C	168	128	36	6	1
	25	□	MPS0550-L25C	195	155	36	6	1
	30	□	MPS0550-L30C	223	183	36	6	1
	35	□	MPS0550-L35C	249	210	36	6	1
40	●	MPS0550-L40C	279	241	36	6	1	
5.55	3	●	MPS0555S-DIN	66	28	36	6	2
	3	●	MPS0555S-DIN-C	66	28	36	6	1
	5	●	MPS0555L-DIN	82	44	36	6	2
	5	●	MPS0555L-DIN-C	82	44	36	6	1

Диам. сверла D1 (мм)	Глубина сверления (l/d)	Наличие VP15TF	Обозначение	Размеры (мм)				Тип
				L1	L3	L9	D4	
5.6	3	●	MPS0560S-DIN	66	28	36	6	2
	3	●	MPS0560S-DIN-C	66	28	36	6	1
	5	●	MPS0560L-DIN	82	44	36	6	2
	5	●	MPS0560L-DIN-C	82	44	36	6	1
	8	●	MPS0560-L8C	107	67	36	6	1
	10	□	MPS0560-L10C	119	79	36	6	1
	12	●	MPS0560-L12C	131	91	36	6	1
	15	●	MPS0560-L15C	149	109	36	6	1
	20	□	MPS0560-L20C	179	139	36	6	1
	25	□	MPS0560-L25C	209	169	36	6	1
	30	□	MPS0560-L30C	239	199	36	6	1
	35	□	MPS0560-L35C	268	223	36	6	1
40	□	MPS0560-L40C	299	251	36	6	1	
5.7	3	●	MPS0570S-DIN	66	28	36	6	2
	3	●	MPS0570S-DIN-C	66	28	36	6	1
	5	●	MPS0570L-DIN	82	44	36	6	2
	5	●	MPS0570L-DIN-C	82	44	36	6	1
	8	●	MPS0570-L8C	107	67	36	6	1
	10	□	MPS0570-L10C	119	79	36	6	1
	12	●	MPS0570-L12C	131	91	36	6	1
	15	●	MPS0570-L15C	149	109	36	6	1
	20	□	MPS0570-L20C	179	139	36	6	1
	25	□	MPS0570-L25C	209	169	36	6	1
	30	□	MPS0570-L30C	239	199	36	6	1
	35	□	MPS0570-L35C	268	223	36	6	1
40	□	MPS0570-L40C	299	251	36	6	1	
5.8	3	●	MPS0580S-DIN	66	28	36	6	2
	3	●	MPS0580S-DIN-C	66	28	36	6	1
	5	●	MPS0580L-DIN	82	44	36	6	2
	5	●	MPS0580L-DIN-C	82	44	36	6	1
	8	●	MPS0580-L8C	107	67	36	6	1
	10	□	MPS0580-L10C	119	79	36	6	1
	12	●	MPS0580-L12C	131	91	36	6	1
	15	●	MPS0580-L15C	149	109	36	6	1
	20	□	MPS0580-L20C	179	139	36	6	1
	25	□	MPS0580-L25C	209	169	36	6	1
	30	□	MPS0580-L30C	239	199	36	6	1
	35	□	MPS0580-L35C	268	229	36	6	1
40	□	MPS0580-L40C	299	261	36	6	1	
5.9	3	●	MPS0590S-DIN	66	28	36	6	2
	3	●	MPS0590S-DIN-C	66	28	36	6	1
	5	●	MPS0590L-DIN	82	44	36	6	2
	5	●	MPS0590L-DIN-C	82	44	36	6	1
	8	●	MPS0590-L8C	107	67	36	6	1
	10	□	MPS0590-L10C	119	79	36	6	1
	12	●	MPS0590-L12C	131	91	36	6	1
	15	●	MPS0590-L15C	149	109	36	6	1
	20	□	MPS0590-L20C	179	139	36	6	1
	25	□	MPS0590-L25C	209	169	36	6	1
	30	□	MPS0590-L30C	239	199	36	6	1
	35	□	MPS0590-L35C	268	229	36	6	1
40	□	MPS0590-L40C	299	261	36	6	1	

● : Есть на складе. □ : Нет на складе, выпускается исключительно под заказ.

Диам. сверла D1 (мм)	Глубина сверления (l/d)	Наличие		Обозначение	Размеры (мм)				Тип
		VP15TF			L1	L3	L9	D4	
6.0	3	●		MPS0600S-DIN	66	28	36	6	2
	3	●		MPS0600S-DIN-C	66	28	36	6	1
	5	●		MPS0600L-DIN	82	44	36	6	2
	5	●		MPS0600L-DIN-C	82	44	36	6	1
	8	●		MPS0600-L8C	107	67	36	6	1
	10	●		MPS0600-L10C	119	79	36	6	1
	12	●		MPS0600-L12C	131	91	36	6	1
	15	●		MPS0600-L15C	149	109	36	6	1
	20	●		MPS0600-L20C	179	139	36	6	1
	25	●		MPS0600-L25C	209	169	36	6	1
	30	●		MPS0600-L30C	239	199	36	6	1
	35	□		MPS0600-L35C	268	229	36	6	1
40	●		MPS0600-L40C	299	261	36	6	1	
6.05	3	●		MPS0605S-DIN	79	34	36	8	2
	3	●		MPS0605S-DIN-C	79	34	36	8	1
	5	●		MPS0605L-DIN	91	53	36	8	2
	5	●		MPS0605L-DIN-C	91	53	36	8	1
6.1	3	●		MPS0610S-DIN	79	34	36	8	2
	3	●		MPS0610S-DIN-C	79	34	36	8	1
	5	●		MPS0610L-DIN	91	53	36	8	2
	5	●		MPS0610L-DIN-C	91	53	36	8	1
	8	●		MPS0610-L8C	113	73	36	8	1
	10	□		MPS0610-L10C	126	86	36	8	1
	12	●		MPS0610-L12C	139	99	36	8	1
	15	●		MPS0610-L15C	158	118	36	8	1
	20	□		MPS0610-L20C	191	151	36	8	1
	25	□		MPS0610-L25C	223	183	36	8	1
	30	□		MPS0610-L30C	256	216	36	8	1
	35	□		MPS0610-L35C	287	241	36	8	1
40	□		MPS0610-L40C	321	271	36	8	1	
6.2	3	●		MPS0620S-DIN	79	34	36	8	2
	3	●		MPS0620S-DIN-C	79	34	36	8	1
	5	●		MPS0620L-DIN	91	53	36	8	2
	5	●		MPS0620L-DIN-C	91	53	36	8	1
	8	●		MPS0620-L8C	113	76	36	8	1
	10	□		MPS0620-L10C	126	86	36	8	1
	12	●		MPS0620-L12C	139	99	36	8	1
	15	●		MPS0620-L15C	158	118	36	8	1
	20	□		MPS0620-L20C	191	151	36	8	1
	25	□		MPS0620-L25C	223	183	36	8	1
	30	□		MPS0620-L30C	256	216	36	8	1
	35	□		MPS0620-L35C	287	241	36	8	1
40	□		MPS0620-L40C	321	271	36	8	1	
6.3	3	●		MPS0630S-DIN	79	34	36	8	2
	3	●		MPS0630S-DIN-C	79	34	36	8	1
	5	●		MPS0630L-DIN	91	53	36	8	2
	5	●		MPS0630L-DIN-C	91	53	36	8	1
	8	●		MPS0630-L8C	113	73	36	8	1
	10	□		MPS0630-L10C	126	86	36	8	1
	12	●		MPS0630-L12C	139	99	36	8	1
	15	●		MPS0630-L15C	158	118	36	8	1
	20	□		MPS0630-L20C	191	151	36	8	1
	25	□		MPS0630-L25C	223	183	36	8	1
	30	□		MPS0630-L30C	256	216	36	8	1
	35	□		MPS0630-L35C	287	248	36	8	1
40	□		MPS0630-L40C	321	281	36	8	1	

Диам. сверла D1 (мм)	Глубина сверления (l/d)	Наличие		Обозначение	Размеры (мм)				Тип
		VP15TF			L1	L3	L9	D4	
6.4	3	●		MPS0640S-DIN	79	34	36	8	2
	3	●		MPS0640S-DIN-C	79	34	36	8	1
	5	●		MPS0640L-DIN	91	53	36	8	2
	5	●		MPS0640L-DIN-C	91	53	36	8	1
	8	●		MPS0640-L8C	113	73	36	8	1
	10	□		MPS0640-L10C	126	86	36	8	1
	12	●		MPS0640-L12C	139	99	36	8	1
	15	●		MPS0640-L15C	158	118	36	8	1
	20	□		MPS0640-L20C	191	151	36	8	1
	25	□		MPS0640-L25C	223	183	36	8	1
	30	□		MPS0640-L30C	256	216	36	8	1
	35	□		MPS0640-L35C	287	248	36	8	1
40	□		MPS0640-L40C	321	281	36	8	1	
6.5	3	●		MPS0650S-DIN	79	34	36	8	2
	3	●		MPS0650S-DIN-C	79	34	36	8	1
	5	●		MPS0650L-DIN	91	53	36	8	2
	5	●		MPS0650L-DIN-C	91	53	36	8	1
	8	●		MPS0650-L8C	113	73	36	8	1
	10	□		MPS0650-L10C	126	86	36	8	1
	12	●		MPS0650-L12C	139	99	36	8	1
	15	●		MPS0650-L15C	158	118	36	8	1
	20	□		MPS0650-L20C	191	151	36	8	1
	25	□		MPS0650-L25C	223	183	36	8	1
	30	□		MPS0650-L30C	256	216	36	8	1
	35	□		MPS0650-L35C	287	248	36	8	1
40	●		MPS0650-L40C	321	281	36	8	1	
6.6	3	●		MPS0660S-DIN	79	34	36	8	2
	3	●		MPS0660S-DIN-C	79	34	36	8	1
	5	●		MPS0660L-DIN	91	53	36	8	2
	5	●		MPS0660L-DIN-C	91	53	36	8	1
	8	●		MPS0660-L8C	118	78	36	8	1
	10	□		MPS0660-L10C	132	92	36	8	1
	12	●		MPS0660-L12C	146	106	36	8	1
	15	●		MPS0660-L15C	167	127	36	8	1
	20	□		MPS0660-L20C	202	162	36	8	1
	25	□		MPS0660-L25C	237	197	36	8	1
	30	□		MPS0660-L30C	272	232	36	8	1
	35	□		MPS0660-L35C	306	267	36	8	1
40	□		MPS0660-L40C	341	301	36	8	1	
6.7	3	●		MPS0670S-DIN	79	34	36	8	2
	3	●		MPS0670S-DIN-C	79	34	36	8	1
	5	●		MPS0670L-DIN	91	53	36	8	2
	5	●		MPS0670L-DIN-C	91	53	36	8	1
	8	●		MPS0670-L8C	118	78	36	8	1
	10	□		MPS0670-L10C	132	92	36	8	1
	12	●		MPS0670-L12C	146	106	36	8	1
	15	●		MPS0670-L15C	167	127	36	8	1
	20	□		MPS0670-L20C	202	162	36	8	1
	25	□		MPS0670-L25C	237	197	36	8	1
	30	□		MPS0670-L30C	272	232	36	8	1
	35	□		MPS0670-L35C	306	267	36	8	1
40	□		MPS0670-L40C	341	301	36	8	1	

# СВЕРЛЕНИЕ (МОНОЛИТНЫЕ ТВЕРДОСПЛАВНЫЕ СВЕРЛА)

## MPS

Тип с двойной ленточкой

ТВЕРДЫЙ  
СПЛАВ

СВЕРЛЕНИЕ

Диам. сверла D1 (мм)	Глубина сверления (l/d)	Наличие		Обозначение	Размеры (мм)				Тип
		VP15TF			L1	L3	L9	D4	
6.8	3	●		MPS0680S-DIN	79	34	36	8	2
	3	●		MPS0680S-DIN-C	79	34	36	8	1
	5	●		MPS0680L-DIN	91	53	36	8	2
	5	●		MPS0680L-DIN-C	91	53	36	8	1
	8	●		MPS0680-L8C	118	78	36	8	1
	10	□		MPS0680-L10C	132	92	36	8	1
	12	●		MPS0680-L12C	146	106	36	8	1
	15	●		MPS0680-L15C	167	127	36	8	1
	20	□		MPS0680-L20C	202	162	36	8	1
	25	□		MPS0680-L25C	237	197	36	8	1
	30	□		MPS0680-L30C	272	232	36	8	1
	35	□		MPS0680-L35C	306	267	36	8	1
40	●		MPS0680-L40C	341	301	36	8	1	
6.9	3	●		MPS0690S-DIN	79	34	36	8	2
	3	●		MPS0690S-DIN-C	79	34	36	8	1
	5	●		MPS0690L-DIN	91	53	36	8	2
	5	●		MPS0690L-DIN-C	91	53	36	8	1
	8	●		MPS0690-L8C	118	78	36	8	1
	10	□		MPS0690-L10C	132	92	36	8	1
	12	●		MPS0690-L12C	146	106	36	8	1
	15	●		MPS0690-L15C	167	127	36	8	1
	20	□		MPS0690-L20C	202	162	36	8	1
	25	□		MPS0690-L25C	237	197	36	8	1
	30	□		MPS0690-L30C	272	232	36	8	1
	35	□		MPS0690-L35C	306	267	36	8	1
40	□		MPS0690-L40C	341	301	36	8	1	
7.0	3	●		MPS0700S-DIN	79	34	36	8	2
	3	●		MPS0700S-DIN-C	79	34	36	8	1
	5	●		MPS0700L-DIN	91	53	36	8	2
	5	●		MPS0700L-DIN-C	91	53	36	8	1
	8	●		MPS0700-L8C	118	78	36	8	1
	10	●		MPS0700-L10C	132	92	36	8	1
	12	●		MPS0700-L12C	146	106	36	8	1
	15	●		MPS0700-L15C	167	127	36	8	1
	20	●		MPS0700-L20C	202	162	36	8	1
	25	□		MPS0700-L25C	237	197	36	8	1
	30	●		MPS0700-L30C	272	232	36	8	1
	35	□		MPS0700-L35C	306	267	36	8	1
40	●		MPS0700-L40C	341	301	36	8	1	
7.1	3	●		MPS0710S-DIN	79	41	36	8	2
	3	●		MPS0710S-DIN-C	79	41	36	8	1
	5	●		MPS0710L-DIN	91	53	36	8	2
	5	●		MPS0710L-DIN-C	91	53	36	8	1
	8	●		MPS0710-L8C	124	84	36	8	1
	10	□		MPS0710-L10C	139	99	36	8	1
	12	●		MPS0710-L12C	154	114	36	8	1
	15	●		MPS0710-L15C	176	136	36	8	1
	20	□		MPS0710-L20C	214	174	36	8	1
	25	□		MPS0710-L25C	251	211	36	8	1
	30	□		MPS0710-L30C	289	249	36	8	1
	35	□		MPS0710-L35C	325	286	36	8	1
40	□		MPS0710-L40C	360	321	36	8	1	

Диам. сверла D1 (мм)	Глубина сверления (l/d)	Наличие		Обозначение	Размеры (мм)				Тип
		VP15TF			L1	L3	L9	D4	
7.2	3	●		MPS0720S-DIN	79	41	36	8	2
	3	●		MPS0720S-DIN-C	79	41	36	8	1
	5	●		MPS0720L-DIN	91	53	36	8	2
	5	●		MPS0720L-DIN-C	91	53	36	8	1
	8	●		MPS0720-L8C	124	84	36	8	1
	10	□		MPS0720-L10C	139	99	36	8	1
	12	●		MPS0720-L12C	154	114	36	8	1
	15	□		MPS0720-L15C	176	136	36	8	1
	20	□		MPS0720-L20C	214	174	36	8	1
	25	□		MPS0720-L25C	251	211	36	8	1
	30	□		MPS0720-L30C	289	249	36	8	1
	35	□		MPS0720-L35C	325	286	36	8	1
40	□		MPS0720-L40C	360	321	36	8	1	
7.3	3	●		MPS0730S-DIN	79	41	36	8	2
	3	●		MPS0730S-DIN-C	79	41	36	8	1
	5	●		MPS0730L-DIN	91	53	36	8	2
	5	●		MPS0730L-DIN-C	91	53	36	8	1
	8	●		MPS0730-L8C	124	84	36	8	1
	10	□		MPS0730-L10C	139	99	36	8	1
	12	●		MPS0730-L12C	154	114	36	8	1
	15	□		MPS0730-L15C	176	136	36	8	1
	20	□		MPS0730-L20C	214	174	36	8	1
	25	□		MPS0730-L25C	251	211	36	8	1
	30	□		MPS0730-L30C	289	249	36	8	1
	35	□		MPS0730-L35C	325	286	36	8	1
40	□		MPS0730-L40C	360	321	36	8	1	
7.4	3	●		MPS0740S-DIN	79	41	36	8	2
	3	●		MPS0740S-DIN-C	79	41	36	8	1
	5	●		MPS0740L-DIN	91	53	36	8	2
	5	●		MPS0740L-DIN-C	91	53	36	8	1
	8	●		MPS0740-L8C	124	84	36	8	1
	10	□		MPS0740-L10C	139	99	36	8	1
	12	●		MPS0740-L12C	154	114	36	8	1
	15	□		MPS0740-L15C	176	136	36	8	1
	20	□		MPS0740-L20C	214	174	36	8	1
	25	□		MPS0740-L25C	251	211	36	8	1
	30	□		MPS0740-L30C	289	249	36	8	1
	35	□		MPS0740-L35C	325	286	36	8	1
40	□		MPS0740-L40C	360	321	36	8	1	
7.5	3	●		MPS0750S-DIN	79	41	36	8	2
	3	●		MPS0750S-DIN-C	79	41	36	8	1
	5	●		MPS0750L-DIN	91	53	36	8	2
	5	●		MPS0750L-DIN-C	91	53	36	8	1
	8	●		MPS0750-L8C	124	84	36	8	1
	10	□		MPS0750-L10C	139	99	36	8	1
	12	●		MPS0750-L12C	154	114	36	8	1
	15	●		MPS0750-L15C	176	136	36	8	1
	20	□		MPS0750-L20C	214	174	36	8	1
	25	□		MPS0750-L25C	251	211	36	8	1
	30	□		MPS0750-L30C	289	249	36	8	1
	35	□		MPS0750-L35C	325	286	36	8	1
40	●		MPS0750-L40C	360	321	36	8	1	

● : Есть на складе. □ : Нет на складе, выпускается исключительно под заказ.

Диам. сверла D1 (мм)	Глубина сверления (l/d)	Наличие		Обозначение	Размеры (мм)				Тип
		VP15TF			L1	L3	L9	D4	
7.6	3	●		MPS0760S-DIN	79	41	36	8	2
	3	●		MPS0760S-DIN-C	79	41	36	8	1
	5	●		MPS0760L-DIN	91	53	36	8	2
	5	●		MPS0760L-DIN-C	91	53	36	8	1
	8	●		MPS0760-L8C	129	89	36	8	1
	10	□		MPS0760-L10C	145	105	36	8	1
	12	●		MPS0760-L12C	161	121	36	8	1
	15	●		MPS0760-L15C	185	145	36	8	1
	20	□		MPS0760-L20C	225	185	36	8	1
	25	□		MPS0760-L25C	265	225	36	8	1
	30	□		MPS0760-L30C	305	265	36	8	1
	35	□		MPS0760-L35C	344	305	36	8	1
40	□		MPS0760-L40C	379	341	36	8	1	
7.7	3	●		MPS0770S-DIN	79	41	36	8	2
	3	●		MPS0770S-DIN-C	79	41	36	8	1
	5	●		MPS0770L-DIN	91	53	36	8	2
	5	●		MPS0770L-DIN-C	91	53	36	8	1
	8	●		MPS0770-L8C	129	89	36	8	1
	10	□		MPS0770-L10C	145	105	36	8	1
	12	●		MPS0770-L12C	161	121	36	8	1
	15	●		MPS0770-L15C	185	145	36	8	1
	20	□		MPS0770-L20C	225	185	36	8	1
	25	□		MPS0770-L25C	265	225	36	8	1
	30	□		MPS0770-L30C	305	265	36	8	1
	35	□		MPS0770-L35C	344	305	36	8	1
40	□		MPS0770-L40C	379	341	36	8	1	
7.8	3	●		MPS0780S-DIN	79	41	36	8	2
	3	●		MPS0780S-DIN-C	79	41	36	8	1
	5	●		MPS0780L-DIN	91	53	36	8	2
	5	●		MPS0780L-DIN-C	91	53	36	8	1
	8	●		MPS0780-L8C	129	89	36	8	1
	10	□		MPS0780-L10C	145	105	36	8	1
	12	●		MPS0780-L12C	161	121	36	8	1
	15	●		MPS0780-L15C	185	145	36	8	1
	20	□		MPS0780-L20C	225	185	36	8	1
	25	□		MPS0780-L25C	265	225	36	8	1
	30	□		MPS0780-L30C	305	265	36	8	1
	35	□		MPS0780-L35C	344	305	36	8	1
40	□		MPS0780-L40C	379	341	36	8	1	
7.9	3	●		MPS0790S-DIN	79	41	36	8	2
	3	●		MPS0790S-DIN-C	79	41	36	8	1
	5	●		MPS0790L-DIN	91	53	36	8	2
	5	●		MPS0790L-DIN-C	91	53	36	8	1
	8	●		MPS0790-L8C	129	89	36	8	1
	10	□		MPS0790-L10C	145	105	36	8	1
	12	●		MPS0790-L12C	161	121	36	8	1
	15	□		MPS0790-L15C	185	145	36	8	1
	20	□		MPS0790-L20C	225	185	36	8	1
	25	□		MPS0790-L25C	265	225	36	8	1
	30	□		MPS0790-L30C	305	265	36	8	1
	35	□		MPS0790-L35C	344	305	36	8	1
40	□		MPS0790-L40C	379	341	36	8	1	

Диам. сверла D1 (мм)	Глубина сверления (l/d)	Наличие		Обозначение	Размеры (мм)				Тип
		VP15TF			L1	L3	L9	D4	
8.0	3	●		MPS0800S-DIN	79	41	36	8	2
	3	●		MPS0800S-DIN-C	79	41	36	8	1
	5	●		MPS0800L-DIN	91	53	36	8	2
	5	●		MPS0800L-DIN-C	91	53	36	8	1
	8	●		MPS0800-L8C	129	89	36	8	1
	10	●		MPS0800-L10C	145	105	36	8	1
	12	●		MPS0800-L12C	161	121	36	8	1
	15	●		MPS0800-L15C	185	145	36	8	1
	20	●		MPS0800-L20C	225	185	36	8	1
	25	●		MPS0800-L25C	265	225	36	8	1
	30	●		MPS0800-L30C	305	265	36	8	1
	35	□		MPS0800-L35C	344	305	36	8	1
40	●		MPS0800-L40C	379	341	36	8	1	
8.05	3	●		MPS0805S-DIN	88	46	40	10	2
	3	●		MPS0805S-DIN-C	88	46	40	10	1
	5	●		MPS0805L-DIN	102	60	40	10	2
	5	●		MPS0805L-DIN-C	102	60	40	10	1
	8	●		MPS0805-L8C	139	95	40	10	1
8.1	3	●		MPS0810S-DIN	88	46	40	10	2
	3	●		MPS0810S-DIN-C	88	46	40	10	1
	5	●		MPS0810L-DIN	102	60	40	10	2
	5	●		MPS0810L-DIN-C	102	60	40	10	1
	8	●		MPS0810-L8C	139	95	40	10	1
	10	□		MPS0810-L10C	156	112	40	10	1
	12	●		MPS0810-L12C	173	129	40	10	1
	15	●		MPS0810-L15C	198	154	40	10	1
	20	□		MPS0810-L20C	241	197	40	10	1
	25	□		MPS0810-L25C	283	239	40	10	1
	30	□		MPS0810-L30C	326	282	40	10	1
	35	□		MPS0810-L35C	367	324	40	10	1
40	□		MPS0810-L40C	411	366	40	10	1	
8.2	3	●		MPS0820S-DIN	88	46	40	10	2
	3	●		MPS0820S-DIN-C	88	46	40	10	1
	5	●		MPS0820L-DIN	102	60	40	10	2
	5	●		MPS0820L-DIN-C	102	60	40	10	1
	8	●		MPS0820-L8C	139	95	40	10	1
	10	□		MPS0820-L10C	156	112	40	10	1
	12	●		MPS0820-L12C	173	129	40	10	1
	15	●		MPS0820-L15C	198	154	40	10	1
	20	□		MPS0820-L20C	241	197	40	10	1
	25	□		MPS0820-L25C	283	239	40	10	1
	30	□		MPS0820-L30C	326	282	40	10	1
	35	□		MPS0820-L35C	367	324	40	10	1
40	□		MPS0820-L40C	411	366	40	10	1	
8.3	3	●		MPS0830S-DIN	88	46	40	10	2
	3	●		MPS0830S-DIN-C	88	46	40	10	1
	5	●		MPS0830L-DIN	102	60	40	10	2
	5	●		MPS0830L-DIN-C	102	60	40	10	1
	8	●		MPS0830-L8C	139	95	40	10	1
	10	□		MPS0830-L10C	156	112	40	10	1
	12	●		MPS0830-L12C	173	129	40	10	1
	15	□		MPS0830-L15C	198	154	40	10	1
	20	□		MPS0830-L20C	241	197	40	10	1
	25	□		MPS0830-L25C	283	239	40	10	1
	30	□		MPS0830-L30C	326	282	40	10	1
	35	□		MPS0830-L35C	368	325	40	10	1
40	□		MPS0830-L40C	412	367	40	10	1	

# СВЕРЛЕНИЕ (МОНОЛИТНЫЕ ТВЕРДОСПЛАВНЫЕ СВЕРЛА)

## MPS

Тип с двойной ленточкой

ТВЕРДЫЙ  
СПЛАВ

СВЕРЛЕНИЕ

Диам. сверла D1 (мм)	Глубина сверления (l/d)	Наличие		Обозначение	Размеры (мм)				Тип
		VP15TF			L1	L3	L9	D4	
8.4	3	●		MPS0840S-DIN	88	46	40	10	2
	3	●		MPS0840S-DIN-C	88	46	40	10	1
	5	●		MPS0840L-DIN	102	60	40	10	2
	5	●		MPS0840L-DIN-C	102	60	40	10	1
	8	●		MPS0840-L8C	139	95	40	10	1
	10	□		MPS0840-L10C	156	112	40	10	1
	12	●		MPS0840-L12C	173	129	40	10	1
	15	●		MPS0840-L15C	198	154	40	10	1
	20	□		MPS0840-L20C	241	197	40	10	1
	25	□		MPS0840-L25C	283	239	40	10	1
	30	□		MPS0840-L30C	326	282	40	10	1
	35	□		MPS0840-L35C	368	325	40	10	1
40	□		MPS0840-L40C	412	367	40	10	1	
8.5	3	●		MPS0850S-DIN	88	46	40	10	2
	3	●		MPS0850S-DIN-C	88	46	40	10	1
	5	●		MPS0850L-DIN	102	60	40	10	2
	5	●		MPS0850L-DIN-C	102	60	40	10	1
	8	●		MPS0850-L8C	139	95	40	10	1
	10	□		MPS0850-L10C	156	112	40	10	1
	12	●		MPS0850-L12C	173	129	40	10	1
	15	●		MPS0850-L15C	198	154	40	10	1
	20	●		MPS0850-L20C	241	197	40	10	1
	25	□		MPS0850-L25C	283	239	40	10	1
	30	□		MPS0850-L30C	326	282	40	10	1
	35	□		MPS0850-L35C	368	325	40	10	1
40	●		MPS0850-L40C	412	367	40	10	1	
8.6	3	●		MPS0860S-DIN	88	46	40	10	2
	3	●		MPS0860S-DIN-C	88	46	40	10	1
	5	●		MPS0860L-DIN	102	60	40	10	2
	5	●		MPS0860L-DIN-C	102	60	40	10	1
	8	●		MPS0860-L8C	144	100	40	10	1
	10	□		MPS0860-L10C	162	118	40	10	1
	12	●		MPS0860-L12C	180	136	40	10	1
	15	●		MPS0860-L15C	207	163	40	10	1
	20	□		MPS0860-L20C	252	208	40	10	1
	25	□		MPS0860-L25C	297	253	40	10	1
	30	□		MPS0860-L30C	342	298	40	10	1
	35	□		MPS0860-L35C	387	344	40	10	1
40	□		MPS0860-L40C	436	392	40	10	1	
8.7	3	●		MPS0870S-DIN	88	46	40	10	2
	3	●		MPS0870S-DIN-C	88	46	40	10	1
	5	●		MPS0870L-DIN	102	60	40	10	2
	5	●		MPS0870L-DIN-C	102	60	40	10	1
	8	●		MPS0870-L8C	144	100	40	10	1
	10	□		MPS0870-L10C	162	118	40	10	1
	12	●		MPS0870-L12C	180	136	40	10	1
	15	●		MPS0870-L15C	207	163	40	10	1
	20	□		MPS0870-L20C	252	208	40	10	1
	25	□		MPS0870-L25C	297	253	40	10	1
	30	□		MPS0870-L30C	342	298	40	10	1
	35	□		MPS0870-L35C	387	344	40	10	1
40	□		MPS0870-L40C	436	392	40	10	1	

Диам. сверла D1 (мм)	Глубина сверления (l/d)	Наличие		Обозначение	Размеры (мм)				Тип
		VP15TF			L1	L3	L9	D4	
8.8	3	●		MPS0880S-DIN	88	46	40	10	2
	3	●		MPS0880S-DIN-C	88	46	40	10	1
	5	●		MPS0880L-DIN	102	60	40	10	2
	5	●		MPS0880L-DIN-C	102	60	40	10	1
	8	●		MPS0880-L8C	144	100	40	10	1
	10	□		MPS0880-L10C	162	118	40	10	1
	12	●		MPS0880-L12C	180	136	40	10	1
	15	●		MPS0880-L15C	207	163	40	10	1
	20	□		MPS0880-L20C	252	208	40	10	1
	25	□		MPS0880-L25C	297	253	40	10	1
	30	□		MPS0880-L30C	342	298	40	10	1
	35	□		MPS0880-L35C	387	344	40	10	1
40	□		MPS0880-L40C	436	392	40	10	1	
8.9	3	●		MPS0890S-DIN	88	46	40	10	2
	3	●		MPS0890S-DIN-C	88	46	40	10	1
	5	●		MPS0890L-DIN	102	60	40	10	2
	5	●		MPS0890L-DIN-C	102	60	40	10	1
	8	●		MPS0890-L8C	144	100	40	10	1
	10	□		MPS0890-L10C	162	118	40	10	1
	12	●		MPS0890-L12C	180	136	40	10	1
	15	□		MPS0890-L15C	207	163	40	10	1
	20	□		MPS0890-L20C	252	208	40	10	1
	25	□		MPS0890-L25C	297	253	40	10	1
	30	□		MPS0890-L30C	342	298	40	10	1
	35	□		MPS0890-L35C	387	344	40	10	1
40	□		MPS0890-L40C	436	392	40	10	1	
9.0	3	●		MPS0900S-DIN	88	46	40	10	2
	3	●		MPS0900S-DIN-C	88	46	40	10	1
	5	●		MPS0900L-DIN	102	60	40	10	2
	5	●		MPS0900L-DIN-C	102	60	40	10	1
	8	●		MPS0900-L8C	144	100	40	10	1
	10	●		MPS0900-L10C	162	118	40	10	1
	12	●		MPS0900-L12C	180	136	40	10	1
	15	●		MPS0900-L15C	207	163	40	10	1
	20	●		MPS0900-L20C	252	208	40	10	1
	25	□		MPS0900-L25C	297	253	40	10	1
	30	□		MPS0900-L30C	342	298	40	10	1
	35	□		MPS0900-L35C	387	344	40	10	1
40	●		MPS0900-L40C	436	392	40	10	1	
9.1	3	●		MPS0910S-DIN	89	47	40	10	2
	3	●		MPS0910S-DIN-C	89	47	40	10	1
	5	●		MPS0910L-DIN	103	62	40	10	2
	5	●		MPS0910L-DIN-C	103	62	40	10	1
	8	●		MPS0910-L8C	151	107	40	10	1
	10	□		MPS0910-L10C	170	126	40	10	1
	12	●		MPS0910-L12C	189	145	40	10	1
	15	●		MPS0910-L15C	217	173	40	10	1
	20	□		MPS0910-L20C	265	221	40	10	1
	25	□		MPS0910-L25C	312	268	40	10	1
	30	□		MPS0910-L30C	360	316	40	10	1
	35	□		MPS0910-L35C	406	363	40	10	1

● : Есть на складе. □ : Нет на складе, выпускается исключительно под заказ.

Диам. сверла D1 (мм)	Глубина сверления (l/d)	Наличие		Обозначение	Размеры (мм)				Тип	
		VP15TF			L1	L3	L9	D4		
9.2	3	●		MPS0920S-DIN	89	47	40	10	2	
	3	●		MPS0920S-DIN-C	89	47	40	10	1	
	5	●		MPS0920L-DIN	103	62	40	10	2	
	5	●		MPS0920L-DIN-C	103	62	40	10	1	
	8	●		MPS0920-L8C	151	107	40	10	1	
	10	□		MPS0920-L10C	170	126	40	10	1	
	12	●		MPS0920-L12C	189	145	40	10	1	
	15	●		MPS0920-L15C	217	173	40	10	1	
	20	□		MPS0920-L20C	265	221	40	10	1	
	25	□		MPS0920-L25C	312	268	40	10	1	
	30	□		MPS0920-L30C	360	316	40	10	1	
	35	□		MPS0920-L35C	406	363	40	10	1	
	9.3	3	●		MPS0930S-DIN	89	47	40	10	2
		3	●		MPS0930S-DIN-C	89	47	40	10	1
5		●		MPS0930L-DIN	103	62	40	10	2	
5		●		MPS0930L-DIN-C	103	62	40	10	1	
8		●		MPS0930-L8C	151	107	40	10	1	
10		□		MPS0930-L10C	170	126	40	10	1	
12		●		MPS0930-L12C	189	145	40	10	1	
15		□		MPS0930-L15C	217	173	40	10	1	
20		□		MPS0930-L20C	265	221	40	10	1	
25		□		MPS0930-L25C	312	268	40	10	1	
30		□		MPS0930-L30C	360	316	40	10	1	
35	□		MPS0930-L35C	406	363	40	10	1		
9.4	3	●		MPS0940S-DIN	89	47	40	10	2	
	3	●		MPS0940S-DIN-C	89	47	40	10	1	
	5	●		MPS0940L-DIN	103	62	40	10	2	
	5	●		MPS0940L-DIN-C	103	62	40	10	1	
	8	●		MPS0940-L8C	151	107	40	10	1	
	10	□		MPS0940-L10C	170	126	40	10	1	
	12	●		MPS0940-L12C	189	145	40	10	1	
	15	□		MPS0940-L15C	217	173	40	10	1	
	20	□		MPS0940-L20C	265	221	40	10	1	
	25	□		MPS0940-L25C	312	268	40	10	1	
	30	□		MPS0940-L30C	360	316	40	10	1	
35	□		MPS0940-L35C	406	363	40	10	1		
9.5	3	●		MPS0950S-DIN	89	47	40	10	2	
	3	●		MPS0950S-DIN-C	89	47	40	10	1	
	5	●		MPS0950L-DIN	103	62	40	10	2	
	5	●		MPS0950L-DIN-C	103	62	40	10	1	
	8	●		MPS0950-L8C	151	107	40	10	1	
	10	□		MPS0950-L10C	170	126	40	10	1	
	12	●		MPS0950-L12C	189	145	40	10	1	
	15	●		MPS0950-L15C	217	173	40	10	1	
	20	□		MPS0950-L20C	265	221	40	10	1	
	25	□		MPS0950-L25C	312	268	40	10	1	
	30	□		MPS0950-L30C	360	316	40	10	1	
35	□		MPS0950-L35C	406	363	40	10	1		
9.6	3	●		MPS0960S-DIN	89	47	40	10	2	
	3	●		MPS0960S-DIN-C	89	47	40	10	1	
	5	●		MPS0960L-DIN	103	62	40	10	2	
	5	●		MPS0960L-DIN-C	103	62	40	10	1	
	8	●		MPS0960-L8C	156	112	40	10	1	
	10	□		MPS0960-L10C	176	132	40	10	1	
9.6	12	●		MPS0960-L12C	196	152	40	10	1	
	15	●		MPS0960-L15C	226	182	40	10	1	

Диам. сверла D1 (мм)	Глубина сверления (l/d)	Наличие		Обозначение	Размеры (мм)				Тип
		VP15TF			L1	L3	L9	D4	
9.6	20	□		MPS0960-L20C	276	232	40	10	1
	25	□		MPS0960-L25C	326	282	40	10	1
	30	□		MPS0960-L30C	376	332	40	10	1
	35	□		MPS0960-L35C	425	382	40	10	1
	9.7	3	●		MPS0970S-DIN	89	47	40	10
3		●		MPS0970S-DIN-C	89	47	40	10	1
5		●		MPS0970L-DIN	103	62	40	10	2
5		●		MPS0970L-DIN-C	103	62	40	10	1
8		●		MPS0970-L8C	156	112	40	10	1
10		□		MPS0970-L10C	176	132	40	10	1
12		●		MPS0970-L12C	196	152	40	10	1
15		●		MPS0970-L15C	226	182	40	10	1
20		□		MPS0970-L20C	276	232	40	10	1
25		□		MPS0970-L25C	326	282	40	10	1
30		□		MPS0970-L30C	376	332	40	10	1
35	□		MPS0970-L35C	425	382	40	10	1	
9.8	3	●		MPS0980S-DIN	89	47	40	10	2
	3	●		MPS0980S-DIN-C	89	47	40	10	1
	5	●		MPS0980L-DIN	103	62	40	10	2
	5	●		MPS0980L-DIN-C	103	62	40	10	1
	8	●		MPS0980-L8C	156	112	40	10	1
	10	□		MPS0980-L10C	176	132	40	10	1
	12	●		MPS0980-L12C	196	152	40	10	1
	15	●		MPS0980-L15C	226	182	40	10	1
	20	□		MPS0980-L20C	276	232	40	10	1
	25	□		MPS0980-L25C	326	282	40	10	1
	30	□		MPS0980-L30C	376	332	40	10	1
35	□		MPS0980-L35C	425	382	40	10	1	
9.9	3	●		MPS0990S-DIN	89	47	40	10	2
	3	●		MPS0990S-DIN-C	89	47	40	10	1
	5	●		MPS0990L-DIN	103	62	40	10	2
	5	●		MPS0990L-DIN-C	103	62	40	10	1
	8	●		MPS0990-L8C	156	112	40	10	1
	10	□		MPS0990-L10C	176	132	40	10	1
	12	●		MPS0990-L12C	196	152	40	10	1
	15	●		MPS0990-L15C	226	182	40	10	1
	20	□		MPS0990-L20C	276	232	40	10	1
	25	□		MPS0990-L25C	326	282	40	10	1
	30	□		MPS0990-L30C	376	332	40	10	1
35	□		MPS0990-L35C	425	382	40	10	1	
10.0	3	●		MPS1000S-DIN	89	47	40	10	2
	3	●		MPS1000S-DIN-C	89	47	40	10	1
	5	●		MPS1000L-DIN	103	62	40	10	2
	5	●		MPS1000L-DIN-C	103	62	40	10	1
	8	●		MPS1000-L8C	156	112	40	10	1
	10	●		MPS1000-L10C	176	132	40	10	1
	12	●		MPS1000-L12C	196	152	40	10	1
	15	●		MPS1000-L15C	226	182	40	10	1
	20	●		MPS1000-L20C	276	232	40	10	1
	25	□		MPS1000-L25C	326	282	40	10	1
	30	□		MPS1000-L30C	376	332	40	10	1
35	□		MPS1000-L35C	425	382	40	10	1	
10.05	3	●		MPS1005S-DIN	102	55	45	12	2
	3	●		MPS1005S-DIN-C	102	55	45	12	1
	5	●		MPS1005L-DIN	118	71	45	12	2
	5	●		MPS1005L-DIN-C	118	71	45	12	1

СВЕРЛЕНИЕ

# СВЕРЛЕНИЕ (МОНОЛИТНЫЕ ТВЕРДОСПЛАВНЫЕ СВЕРЛА)

## MPS

Тип с двойной ленточкой

ТВЕРДЫЙ  
СПЛАВ

СВЕРЛЕНИЕ

Диам. сверла D1 (мм)	Глубина сверления (l/d)	Наличие		Обозначение	Размеры (мм)				Тип
		VP15TF			L1	L3	L9	D4	
10.1	3	●		MPS1010S-DIN	102	55	45	12	2
	3	●		MPS1010S-DIN-C	102	55	45	12	1
	5	●		MPS1010L-DIN	118	71	45	12	2
	5	●		MPS1010L-DIN-C	118	71	45	12	1
	8	●		MPS1010-L8C	167	118	45	12	1
	10	□		MPS1010-L10C	188	139	45	12	1
	12	●		MPS1010-L12C	209	160	45	12	1
	15	●		MPS1010-L15C	240	191	45	12	1
	20	□		MPS1010-L20C	293	244	45	12	1
	25	□		MPS1010-L25C	345	296	45	12	1
10.2	3	●		MPS1020S-DIN	102	55	45	12	2
	3	●		MPS1020S-DIN-C	102	55	45	12	1
	5	●		MPS1020L-DIN	118	71	45	12	2
	5	●		MPS1020L-DIN-C	118	71	45	12	1
	8	●		MPS1020-L8C	167	118	45	12	1
	10	□		MPS1020-L10C	188	139	45	12	1
	12	●		MPS1020-L12C	209	160	45	12	1
	15	●		MPS1020-L15C	240	191	45	12	1
	20	□		MPS1020-L20C	293	244	45	12	1
	25	□		MPS1020-L25C	345	296	45	12	1
10.3	3	●		MPS1030S-DIN	102	55	45	12	2
	3	●		MPS1030S-DIN-C	102	55	45	12	1
	5	●		MPS1030L-DIN	118	71	45	12	2
	5	●		MPS1030L-DIN-C	118	71	45	12	1
	8	●		MPS1030-L8C	167	118	45	12	1
	10	□		MPS1030-L10C	188	139	45	12	1
	12	●		MPS1030-L12C	209	160	45	12	1
	15	□		MPS1030-L15C	240	191	45	12	1
	20	□		MPS1030-L20C	293	244	45	12	1
	25	□		MPS1030-L25C	345	296	45	12	1
10.4	3	●		MPS1040S-DIN	102	55	45	12	2
	3	●		MPS1040S-DIN-C	102	55	45	12	1
	5	●		MPS1040L-DIN	118	71	45	12	2
	5	●		MPS1040L-DIN-C	118	71	45	12	1
	8	●		MPS1040-L8C	167	118	45	12	1
	10	□		MPS1040-L10C	188	139	45	12	1
	12	●		MPS1040-L12C	209	160	45	12	1
	15	□		MPS1040-L15C	240	191	45	12	1
	20	□		MPS1040-L20C	293	244	45	12	1
	25	□		MPS1040-L25C	345	296	45	12	1
10.5	3	●		MPS1050S-DIN	102	55	45	12	2
	3	●		MPS1050S-DIN-C	102	55	45	12	1
	5	●		MPS1050L-DIN	118	71	45	12	2
	5	●		MPS1050L-DIN-C	118	71	45	12	1
	8	●		MPS1050-L8C	167	118	45	12	1
	10	□		MPS1050-L10C	188	139	45	12	1
	12	●		MPS1050-L12C	209	160	45	12	1
	15	●		MPS1050-L15C	240	191	45	12	1
	20	□		MPS1050-L20C	293	244	45	12	1
	25	□		MPS1050-L25C	345	296	45	12	1
10.6	3	●		MPS1060S-DIN	102	55	45	12	2
	3	●		MPS1060S-DIN-C	102	55	45	12	1
	5	●		MPS1060L-DIN	118	71	45	12	2
	5	●		MPS1060L-DIN-C	118	71	45	12	1
	8	●		MPS1060-L8C	172	123	45	12	1

Диам. сверла D1 (мм)	Глубина сверления (l/d)	Наличие		Обозначение	Размеры (мм)				Тип
		VP15TF			L1	L3	L9	D4	
10.6	10	□		MPS1060-L10C	194	145	45	12	1
	12	□		MPS1060-L12C	216	167	45	12	1
	15	□		MPS1060-L15C	249	200	45	12	1
	20	□		MPS1060-L20C	304	255	45	12	1
	25	□		MPS1060-L25C	359	310	45	12	1
	10.7	3	●		MPS1070S-DIN	102	55	45	12
3		●		MPS1070S-DIN-C	102	55	45	12	1
5		●		MPS1070L-DIN	118	71	45	12	2
5		●		MPS1070L-DIN-C	118	71	45	12	1
8		●		MPS1070-L8C	172	123	45	12	1
10		□		MPS1070-L10C	194	145	45	12	1
12		●		MPS1070-L12C	216	167	45	12	1
15		□		MPS1070-L15C	249	200	45	12	1
20		□		MPS1070-L20C	304	255	45	12	1
25		□		MPS1070-L25C	359	310	45	12	1
10.8	3	●		MPS1080S-DIN	102	55	45	12	2
	3	●		MPS1080S-DIN-C	102	55	45	12	1
	5	●		MPS1080L-DIN	118	71	45	12	2
	5	●		MPS1080L-DIN-C	118	71	45	12	1
	8	●		MPS1080-L8C	172	123	45	12	1
	10	□		MPS1080-L10C	194	145	45	12	1
	12	●		MPS1080-L12C	216	167	45	12	1
	15	□		MPS1080-L15C	249	200	45	12	1
	20	□		MPS1080-L20C	304	255	45	12	1
	25	□		MPS1080-L25C	359	310	45	12	1
10.9	3	●		MPS1090S-DIN	102	55	45	12	2
	3	●		MPS1090S-DIN-C	102	55	45	12	1
	5	●		MPS1090L-DIN	118	71	45	12	2
	5	●		MPS1090L-DIN-C	118	71	45	12	1
	8	●		MPS1090-L8C	172	123	45	12	1
	10	□		MPS1090-L10C	194	145	45	12	1
	12	□		MPS1090-L12C	216	167	45	12	1
	15	□		MPS1090-L15C	249	200	45	12	1
	20	□		MPS1090-L20C	304	255	45	12	1
	25	□		MPS1090-L25C	359	310	45	12	1
11.0	3	●		MPS1100S-DIN	102	55	45	12	2
	3	●		MPS1100S-DIN-C	102	55	45	12	1
	5	●		MPS1100L-DIN	118	71	45	12	2
	5	●		MPS1100L-DIN-C	118	71	45	12	1
	8	●		MPS1100-L8C	172	123	45	12	1
	10	□		MPS1100-L10C	194	145	45	12	1
	12	●		MPS1100-L12C	216	167	45	12	1
	15	●		MPS1100-L15C	249	200	45	12	1
	20	□		MPS1100-L20C	304	255	45	12	1
	25	□		MPS1100-L25C	359	310	45	12	1
11.1	3	●		MPS1110S-DIN	102	55	45	12	2
	3	●		MPS1110S-DIN-C	102	55	45	12	1
	5	●		MPS1110L-DIN	118	71	45	12	2
	5	●		MPS1110L-DIN-C	118	71	45	12	1
	8	●		MPS1110-L8C	178	129	45	12	1
	10	□		MPS1110-L10C	201	152	45	12	1
	12	●		MPS1110-L12C	224	175	45	12	1
	15	●		MPS1110-L15C	258	209	45	12	1
	20	□		MPS1110-L20C	316	267	45	12	1
	25	□		MPS1110-L25C	373	324	45	12	1

● : Есть на складе. □ : Нет на складе, выпускается исключительно под заказ.

Диам. сверла D1 (мм)	Глубина сверления (l/d)	Наличие		Обозначение	Размеры (мм)				Тип
		VP15TF			L1	L3	L9	D4	
11.2	3	●		MPS1120S-DIN	102	55	45	12	2
	3	●		MPS1120S-DIN-C	102	55	45	12	1
	5	●		MPS1120L-DIN	118	71	45	12	2
	5	●		MPS1120L-DIN-C	118	71	45	12	1
	8	●		MPS1120-L8C	178	129	45	12	1
	10	□		MPS1120-L10C	201	152	45	12	1
	12	□		MPS1120-L12C	224	175	45	12	1
	15	●		MPS1120-L15C	258	209	45	12	1
	20	□		MPS1120-L20C	316	267	45	12	1
	25	□		MPS1120-L25C	373	324	45	12	1
11.3	3	●		MPS1130S-DIN	102	55	45	12	2
	3	●		MPS1130S-DIN-C	102	55	45	12	1
	5	●		MPS1130L-DIN	118	71	45	12	2
	5	●		MPS1130L-DIN-C	118	71	45	12	1
	8	●		MPS1130-L8C	178	129	45	12	1
	10	□		MPS1130-L10C	201	152	45	12	1
	12	□		MPS1130-L12C	224	175	45	12	1
	15	□		MPS1130-L15C	258	209	45	12	1
	20	□		MPS1130-L20C	316	267	45	12	1
	25	□		MPS1130-L25C	373	324	45	12	1
11.4	3	●		MPS1140S-DIN	102	55	45	12	2
	3	●		MPS1140S-DIN-C	102	55	45	12	1
	5	●		MPS1140L-DIN	118	71	45	12	2
	5	●		MPS1140L-DIN-C	118	71	45	12	1
	8	●		MPS1140-L8C	178	129	45	12	1
	10	□		MPS1140-L10C	201	152	45	12	1
	12	□		MPS1140-L12C	224	175	45	12	1
	15	□		MPS1140-L15C	258	209	45	12	1
	20	□		MPS1140-L20C	316	267	45	12	1
	25	□		MPS1140-L25C	373	324	45	12	1
11.5	3	●		MPS1150S-DIN	102	55	45	12	2
	3	●		MPS1150S-DIN-C	102	55	45	12	1
	5	●		MPS1150L-DIN	118	71	45	12	2
	5	●		MPS1150L-DIN-C	118	71	45	12	1
	8	●		MPS1150-L8C	178	129	45	12	1
	10	□		MPS1150-L10C	201	152	45	12	1
	12	●		MPS1150-L12C	224	175	45	12	1
	15	●		MPS1150-L15C	258	209	45	12	1
	20	□		MPS1150-L20C	316	267	45	12	1
	25	□		MPS1150-L25C	373	324	45	12	1
11.6	3	●		MPS1160S-DIN	102	55	45	12	2
	3	●		MPS1160S-DIN-C	102	55	45	12	1
	5	●		MPS1160L-DIN	118	71	45	12	2
	5	●		MPS1160L-DIN-C	118	71	45	12	1
	8	●		MPS1160-L8C	183	134	45	12	1
	10	□		MPS1160-L10C	207	158	45	12	1
	12	□		MPS1160-L12C	231	182	45	12	1
	15	□		MPS1160-L15C	267	218	45	12	1
	20	□		MPS1160-L20C	327	278	45	12	1
	25	□		MPS1160-L25C	387	338	45	12	1

Диам. сверла D1 (мм)	Глубина сверления (l/d)	Наличие		Обозначение	Размеры (мм)				Тип
		VP15TF			L1	L3	L9	D4	
11.7	3	●		MPS1170S-DIN	102	55	45	12	2
	3	●		MPS1170S-DIN-C	102	55	45	12	1
	5	●		MPS1170L-DIN	118	71	45	12	2
	5	●		MPS1170L-DIN-C	118	71	45	12	1
	8	●		MPS1170-L8C	183	134	45	12	1
	10	□		MPS1170-L10C	207	158	45	12	1
	12	●		MPS1170-L12C	231	182	45	12	1
	15	●		MPS1170-L15C	267	218	45	12	1
	20	□		MPS1170-L20C	327	278	45	12	1
	25	□		MPS1170-L25C	387	338	45	12	1
11.8	3	●		MPS1180S-DIN	102	55	45	12	2
	3	●		MPS1180S-DIN-C	102	55	45	12	1
	5	●		MPS1180L-DIN	118	71	45	12	2
	5	●		MPS1180L-DIN-C	118	71	45	12	1
	8	●		MPS1180-L8C	183	134	45	12	1
	10	□		MPS1180-L10C	207	158	45	12	1
	12	●		MPS1180-L12C	231	182	45	12	1
	15	●		MPS1180-L15C	267	218	45	12	1
	20	□		MPS1180-L20C	327	278	45	12	1
	25	□		MPS1180-L25C	387	338	45	12	1
11.9	3	●		MPS1190S-DIN	102	55	45	12	2
	3	●		MPS1190S-DIN-C	102	55	45	12	1
	5	●		MPS1190L-DIN	118	71	45	12	2
	5	●		MPS1190L-DIN-C	118	71	45	12	1
	8	●		MPS1190-L8C	183	134	45	12	1
	10	□		MPS1190-L10C	207	158	45	12	1
	12	□		MPS1190-L12C	231	182	45	12	1
	15	□		MPS1190-L15C	267	218	45	12	1
	20	□		MPS1190-L20C	327	278	45	12	1
	25	□		MPS1190-L25C	387	338	45	12	1
12.0	3	●		MPS1200S-DIN	102	55	45	12	2
	3	●		MPS1200S-DIN-C	102	55	45	12	1
	5	●		MPS1200L-DIN	118	71	45	12	2
	5	●		MPS1200L-DIN-C	118	71	45	12	1
	8	●		MPS1200-L8C	183	134	45	12	1
	10	□		MPS1200-L10C	207	158	45	12	1
	12	●		MPS1200-L12C	231	182	45	12	1
	15	●		MPS1200-L15C	267	218	45	12	1
	20	□		MPS1200-L20C	327	278	45	12	1
	25	□		MPS1200-L25C	387	338	45	12	1
12.05	3	●		MPS1205S-DIN	107	60	45	14	2
	3	●		MPS1205S-DIN-C	107	60	45	14	1
	5	●		MPS1205L-DIN	124	77	45	14	2
	5	●		MPS1205L-DIN-C	124	77	45	14	1
12.1	3	●		MPS1210S-DIN	107	60	45	14	2
	3	●		MPS1210S-DIN-C	107	60	45	14	1
	5	●		MPS1210L-DIN	124	77	45	14	2
	5	●		MPS1210L-DIN-C	124	77	45	14	1
	8	●		MPS1210-L8C	189	140	45	14	1
	10	□		MPS1210-L10C	214	165	45	14	1
	12	●		MPS1210-L12C	239	190	45	14	1
	15	●		MPS1210-L15C	276	227	45	14	1
20	□		MPS1210-L20C	339	290	45	14	1	

СВЕРЛЕНИЕ

# СВЕРЛЕНИЕ (МОНОЛИТНЫЕ ТВЕРДОСПЛАВНЫЕ СВЕРЛА)

## MPS

Тип с двойной ленточкой

ТВЕРДЫЙ  
СПЛАВ

СВЕРЛЕНИЕ

Диам. сверла D1 (мм)	Глубина сверления (l/d)	Наличие VP15TF	Обозначение	Размеры (мм)				Тип
				L1	L3	L9	D4	
12.2	3	●	MPS1220S-DIN	107	60	45	14	2
	3	●	MPS1220S-DIN-C	107	60	45	14	1
	5	●	MPS1220L-DIN	124	77	45	14	2
	5	●	MPS1220L-DIN-C	124	77	45	14	1
	8	●	MPS1220-L8C	189	140	45	14	1
	10	□	MPS1220-L10C	214	165	45	14	1
	12	●	MPS1220-L12C	239	190	45	14	1
	15	●	MPS1220-L15C	276	227	45	14	1
20	□	MPS1220-L20C	339	290	45	14	1	
12.3	3	●	MPS1230S-DIN	107	60	45	14	2
	3	●	MPS1230S-DIN-C	107	60	45	14	1
	5	●	MPS1230L-DIN	124	77	45	14	2
	5	●	MPS1230L-DIN-C	124	77	45	14	1
	8	●	MPS1230-L8C	189	140	45	14	1
	10	□	MPS1230-L10C	214	165	45	14	1
	12	□	MPS1230-L12C	239	190	45	14	1
	15	□	MPS1230-L15C	276	227	45	14	1
20	□	MPS1230-L20C	339	290	45	14	1	
12.4	3	●	MPS1240S-DIN	107	60	45	14	2
	3	●	MPS1240S-DIN-C	107	60	45	14	1
	5	●	MPS1240L-DIN	124	77	45	14	2
	5	●	MPS1240L-DIN-C	124	77	45	14	1
	8	●	MPS1240-L8C	189	140	45	14	1
	10	□	MPS1240-L10C	214	165	45	14	1
	12	□	MPS1240-L12C	239	190	45	14	1
	15	□	MPS1240-L15C	276	227	45	14	1
20	□	MPS1240-L20C	339	290	45	14	1	
12.5	3	●	MPS1250S-DIN	107	60	45	14	2
	3	●	MPS1250S-DIN-C	107	60	45	14	1
	5	●	MPS1250L-DIN	124	77	45	14	2
	5	●	MPS1250L-DIN-C	124	77	45	14	1
	8	●	MPS1250-L8C	189	140	45	14	1
	10	□	MPS1250-L10C	214	165	45	14	1
	12	●	MPS1250-L12C	239	190	45	14	1
	15	●	MPS1250-L15C	276	227	45	14	1
20	□	MPS1250-L20C	339	290	45	14	1	
12.6	3	●	MPS1260S-DIN	107	60	45	14	2
	3	●	MPS1260S-DIN-C	107	60	45	14	1
	5	●	MPS1260L-DIN	124	77	45	14	2
	5	●	MPS1260L-DIN-C	124	77	45	14	1
	8	●	MPS1260-L8C	194	145	45	14	1
	10	□	MPS1260-L10C	220	171	45	14	1
	12	□	MPS1260-L12C	246	197	45	14	1
	15	□	MPS1260-L15C	285	236	45	14	1
20	□	MPS1260-L20C	350	301	45	14	1	
12.7	3	●	MPS1270S-DIN	107	60	45	14	2
	3	●	MPS1270S-DIN-C	107	60	45	14	1
	5	●	MPS1270L-DIN	124	77	45	14	2
	5	●	MPS1270L-DIN-C	124	77	45	14	1
	8	●	MPS1270-L8C	194	145	45	14	1
	10	□	MPS1270-L10C	220	171	45	14	1
	12	●	MPS1270-L12C	246	197	45	14	1
	15	□	MPS1270-L15C	285	236	45	14	1
20	□	MPS1270-L20C	350	301	45	14	1	

Диам. сверла D1 (мм)	Глубина сверления (l/d)	Наличие VP15TF	Обозначение	Размеры (мм)				Тип
				L1	L3	L9	D4	
12.8	3	●	MPS1280S-DIN	107	60	45	14	2
	3	●	MPS1280S-DIN-C	107	60	45	14	1
	5	●	MPS1280L-DIN	124	77	45	14	2
	5	●	MPS1280L-DIN-C	124	77	45	14	1
	8	●	MPS1280-L8C	194	145	45	14	1
	10	□	MPS1280-L10C	220	171	45	14	1
	12	●	MPS1280-L12C	246	197	45	14	1
	15	□	MPS1280-L15C	285	236	45	14	1
20	□	MPS1280-L20C	350	301	45	14	1	
12.9	3	●	MPS1290S-DIN	107	60	45	14	2
	3	●	MPS1290S-DIN-C	107	60	45	14	1
	5	●	MPS1290L-DIN	124	77	45	14	2
	5	●	MPS1290L-DIN-C	124	77	45	14	1
	8	●	MPS1290-L8C	194	145	45	14	1
	10	□	MPS1290-L10C	220	171	45	14	1
	12	□	MPS1290-L12C	246	197	45	14	1
	15	□	MPS1290-L15C	285	236	45	14	1
20	□	MPS1290-L20C	350	301	45	14	1	
13.0	3	●	MPS1300S-DIN	107	60	45	14	2
	3	●	MPS1300S-DIN-C	107	60	45	14	1
	5	●	MPS1300L-DIN	124	77	45	14	2
	5	●	MPS1300L-DIN-C	124	77	45	14	1
	8	●	MPS1300-L8C	194	145	45	14	1
	10	□	MPS1300-L10C	220	171	45	14	1
	12	●	MPS1300-L12C	246	197	45	14	1
	15	●	MPS1300-L15C	285	236	45	14	1
20	□	MPS1300-L20C	350	301	45	14	1	
13.1	3	●	MPS1310S-DIN	107	60	45	14	2
	3	●	MPS1310S-DIN-C	107	60	45	14	1
	5	●	MPS1310L-DIN	124	77	45	14	2
	5	●	MPS1310L-DIN-C	124	77	45	14	1
	8	●	MPS1310-L8C	200	151	45	14	1
	10	□	MPS1310-L10C	227	178	45	14	1
	12	□	MPS1310-L12C	254	205	45	14	1
	15	□	MPS1310-L15C	294	245	45	14	1
20	□	MPS1310-L20C	362	313	45	14	1	
13.2	3	●	MPS1320S-DIN	107	60	45	14	2
	3	●	MPS1320S-DIN-C	107	60	45	14	1
	5	●	MPS1320L-DIN	124	77	45	14	2
	5	●	MPS1320L-DIN-C	124	77	45	14	1
	8	●	MPS1320-L8C	200	151	45	14	1
	10	□	MPS1320-L10C	227	178	45	14	1
	12	●	MPS1320-L12C	254	205	45	14	1
	15	□	MPS1320-L15C	294	245	45	14	1
20	□	MPS1320-L20C	362	313	45	14	1	
13.3	3	●	MPS1330S-DIN	107	60	45	14	2
	3	●	MPS1330S-DIN-C	107	60	45	14	1
	5	●	MPS1330L-DIN	124	77	45	14	2
	5	●	MPS1330L-DIN-C	124	77	45	14	1
	8	●	MPS1330-L8C	200	151	45	14	1
	10	□	MPS1330-L10C	227	178	45	14	1
	12	□	MPS1330-L12C	254	205	45	14	1
	15	□	MPS1330-L15C	294	245	45	14	1
20	□	MPS1330-L20C	362	313	45	14	1	

● : Есть на складе. □ : Нет на складе, выпускается исключительно под заказ.

Диам. сверла D1 (мм)	Глубина сверления (l/d)	Наличие		Обозначение	Размеры (мм)				Тип
		VP15TF			L1	L3	L9	D4	
13.4	3	●		MPS1340S-DIN	107	60	45	14	2
	3	●		MPS1340S-DIN-C	107	60	45	14	1
	5	●		MPS1340L-DIN	124	77	45	14	2
	5	●		MPS1340L-DIN-C	124	77	45	14	1
	8	●		MPS1340-L8C	200	151	45	14	1
	10	□		MPS1340-L10C	227	178	45	14	1
	12	□		MPS1340-L12C	254	205	45	14	1
	15	□		MPS1340-L15C	294	245	45	14	1
20	□		MPS1340-L20C	362	313	45	14	1	
13.5	3	●		MPS1350S-DIN	107	60	45	14	2
	3	●		MPS1350S-DIN-C	107	60	45	14	1
	5	●		MPS1350L-DIN	124	77	45	14	2
	5	●		MPS1350L-DIN-C	124	77	45	14	1
	8	●		MPS1350-L8C	200	151	45	14	1
	10	□		MPS1350-L10C	227	178	45	14	1
	12	●		MPS1350-L12C	254	205	45	14	1
	15	□		MPS1350-L15C	294	245	45	14	1
20	□		MPS1350-L20C	362	313	45	14	1	
13.6	3	●		MPS1360S-DIN	107	60	45	14	2
	3	●		MPS1360S-DIN-C	107	60	45	14	1
	5	●		MPS1360L-DIN	124	77	45	14	2
	5	●		MPS1360L-DIN-C	124	77	45	14	1
	8	●		MPS1360-L8C	205	156	45	14	1
	10	□		MPS1360-L10C	233	184	45	14	1
	12	□		MPS1360-L12C	261	212	45	14	1
	15	□		MPS1360-L15C	303	254	45	14	1
20	□		MPS1360-L20C	373	324	45	14	1	
13.7	3	●		MPS1370S-DIN	107	60	45	14	2
	3	●		MPS1370S-DIN-C	107	60	45	14	1
	5	●		MPS1370L-DIN	124	77	45	14	2
	5	●		MPS1370L-DIN-C	124	77	45	14	1
	8	●		MPS1370-L8C	205	156	45	14	1
	10	□		MPS1370-L10C	233	184	45	14	1
	12	□		MPS1370-L12C	261	212	45	14	1
	15	□		MPS1370-L15C	303	254	45	14	1
20	□		MPS1370-L20C	373	324	45	14	1	
13.8	3	●		MPS1380S-DIN	107	60	45	14	2
	3	●		MPS1380S-DIN-C	107	60	45	14	1
	5	●		MPS1380L-DIN	124	77	45	14	2
	5	●		MPS1380L-DIN-C	124	77	45	14	1
	8	●		MPS1380-L8C	205	156	45	14	1
	10	□		MPS1380-L10C	233	184	45	14	1
	12	□		MPS1380-L12C	261	212	45	14	1
	15	□		MPS1380-L15C	303	254	45	14	1
20	□		MPS1380-L20C	373	324	45	14	1	
13.9	3	●		MPS1390S-DIN	107	60	45	14	2
	3	●		MPS1390S-DIN-C	107	60	45	14	1
	5	●		MPS1390L-DIN	124	77	45	14	2
	5	●		MPS1390L-DIN-C	124	77	45	14	1
	8	●		MPS1390-L8C	205	156	45	14	1
	10	□		MPS1390-L10C	233	184	45	14	1
	12	□		MPS1390-L12C	261	212	45	14	1
	15	□		MPS1390-L15C	303	254	45	14	1
20	□		MPS1390-L20C	373	324	45	14	1	

Диам. сверла D1 (мм)	Глубина сверления (l/d)	Наличие		Обозначение	Размеры (мм)				Тип
		VP15TF			L1	L3	L9	D4	
14.0	3	●		MPS1400S-DIN	107	60	45	14	2
	3	●		MPS1400S-DIN-C	107	60	45	14	1
	5	●		MPS1400L-DIN	124	77	45	14	2
	5	●		MPS1400L-DIN-C	124	77	45	14	1
	8	●		MPS1400-L8C	205	156	45	14	1
	10	□		MPS1400-L10C	233	184	45	14	1
	12	●		MPS1400-L12C	261	212	45	14	1
	15	●		MPS1400-L15C	303	254	45	14	1
20	□		MPS1400-L20C	373	324	45	14	1	
14.1	3	□		MPS1410S-DIN	114	64	48	16	2
	3	□		MPS1410S-DIN-C	114	64	48	16	1
	5	□		MPS1410L-DIN	132	82	48	16	2
	5	□		MPS1410L-DIN-C	132	82	48	16	1
14.2	3	●		MPS1420S-DIN	114	64	48	16	2
	3	●		MPS1420S-DIN-C	114	64	48	16	1
	5	●		MPS1420L-DIN	132	82	48	16	2
5	●		MPS1420L-DIN-C	132	82	48	16	1	
14.3	3	□		MPS1430S-DIN	114	64	48	16	2
	3	□		MPS1430S-DIN-C	114	64	48	16	1
	5	□		MPS1430L-DIN	132	82	48	16	2
5	□		MPS1430L-DIN-C	132	82	48	16	1	
14.4	3	□		MPS1440S-DIN	114	64	48	16	2
	3	□		MPS1440S-DIN-C	114	64	48	16	1
	5	□		MPS1440L-DIN	132	82	48	16	2
5	□		MPS1440L-DIN-C	132	82	48	16	1	
14.5	3	●		MPS1450S-DIN	114	64	48	16	2
	3	●		MPS1450S-DIN-C	114	64	48	16	1
	5	●		MPS1450L-DIN	132	82	48	16	2
5	●		MPS1450L-DIN-C	132	82	48	16	1	
14.6	3	□		MPS1460S-DIN	114	64	48	16	2
	3	□		MPS1460S-DIN-C	114	64	48	16	1
	5	□		MPS1460L-DIN	132	82	48	16	2
5	□		MPS1460L-DIN-C	132	82	48	16	1	
14.7	3	□		MPS1470S-DIN	114	64	48	16	2
	3	□		MPS1470S-DIN-C	114	64	48	16	1
	5	□		MPS1470L-DIN	132	82	48	16	2
5	□		MPS1470L-DIN-C	132	82	48	16	1	
14.8	3	□		MPS1480S-DIN	114	64	48	16	2
	3	□		MPS1480S-DIN-C	114	64	48	16	1
	5	□		MPS1480L-DIN	132	82	48	16	2
5	□		MPS1480L-DIN-C	132	82	48	16	1	
14.9	3	□		MPS1490S-DIN	114	64	48	16	2
	3	□		MPS1490S-DIN-C	114	64	48	16	1
	5	□		MPS1490L-DIN	132	82	48	16	2
5	□		MPS1490L-DIN-C	132	82	48	16	1	
15.0	3	●		MPS1500S-DIN	114	64	48	16	2
	3	●		MPS1500S-DIN-C	114	64	48	16	1
	5	●		MPS1500L-DIN	132	82	48	16	2
	5	●		MPS1500L-DIN-C	132	82	48	16	1
15.1	3	□		MPS1510S-DIN	115	65	48	16	2
	3	□		MPS1510S-DIN-C	115	65	48	16	1
	5	□		MPS1510L-DIN	133	83	48	16	2
5	□		MPS1510L-DIN-C	133	83	48	16	1	

# СВЕРЛЕНИЕ (МОНОЛИТНЫЕ ТВЕРДОСПЛАВНЫЕ СВЕРЛА)

## MPS

Тип с двойной ленточкой

ТВЕРДЫЙ  
СПЛАВ

СВЕРЛЕНИЕ

Диам. сверла D1 (мм)	Глубина сверления (l/d)	Наличие		Обозначение	Размеры (мм)				Тип
		VP15TF			L1	L3	L9	D4	
15.2	3	<input type="checkbox"/>		MPS1520S-DIN	115	65	48	16	2
	3	<input type="checkbox"/>		MPS1520S-DIN-C	115	65	48	16	1
	5	<input type="checkbox"/>		MPS1520L-DIN	133	83	48	16	2
	5	<input type="checkbox"/>		MPS1520L-DIN-C	133	83	48	16	1
15.3	3	<input type="checkbox"/>		MPS1530S-DIN	115	65	48	16	2
	3	<input type="checkbox"/>		MPS1530S-DIN-C	115	65	48	16	1
	5	<input type="checkbox"/>		MPS1530L-DIN	133	83	48	16	2
	5	<input type="checkbox"/>		MPS1530L-DIN-C	133	83	48	16	1
15.4	3	<input type="checkbox"/>		MPS1540S-DIN	115	65	48	16	2
	3	<input type="checkbox"/>		MPS1540S-DIN-C	115	65	48	16	1
	5	<input type="checkbox"/>		MPS1540L-DIN	133	83	48	16	2
	5	<input type="checkbox"/>		MPS1540L-DIN-C	133	83	48	16	1
15.5	3	<input checked="" type="checkbox"/>		MPS1550S-DIN	115	65	48	16	2
	3	<input checked="" type="checkbox"/>		MPS1550S-DIN-C	115	65	48	16	1
	5	<input checked="" type="checkbox"/>		MPS1550L-DIN	133	83	48	16	2
	5	<input checked="" type="checkbox"/>		MPS1550L-DIN-C	133	83	48	16	1
15.6	3	<input type="checkbox"/>		MPS1560S-DIN	115	65	48	16	2
	3	<input type="checkbox"/>		MPS1560S-DIN-C	115	65	48	16	1
	5	<input type="checkbox"/>		MPS1560L-DIN	133	83	48	16	2
	5	<input type="checkbox"/>		MPS1560L-DIN-C	133	83	48	16	1
15.7	3	<input type="checkbox"/>		MPS1570S-DIN	115	65	48	16	2
	3	<input type="checkbox"/>		MPS1570S-DIN-C	115	65	48	16	1
	5	<input type="checkbox"/>		MPS1570L-DIN	133	83	48	16	2
	5	<input type="checkbox"/>		MPS1570L-DIN-C	133	83	48	16	1
15.8	3	<input type="checkbox"/>		MPS1580S-DIN	115	65	48	16	2
	3	<input type="checkbox"/>		MPS1580S-DIN-C	115	65	48	16	1
	5	<input type="checkbox"/>		MPS1580L-DIN	133	83	48	16	2
	5	<input type="checkbox"/>		MPS1580L-DIN-C	133	83	48	16	1
15.9	3	<input type="checkbox"/>		MPS1590S-DIN	115	65	48	16	2
	3	<input type="checkbox"/>		MPS1590S-DIN-C	115	65	48	16	1
	5	<input type="checkbox"/>		MPS1590L-DIN	133	83	48	16	2
	5	<input type="checkbox"/>		MPS1590L-DIN-C	133	83	48	16	1
16.0	3	<input checked="" type="checkbox"/>		MPS1600S-DIN	115	65	48	16	2
	3	<input checked="" type="checkbox"/>		MPS1600S-DIN-C	115	65	48	16	1
	5	<input checked="" type="checkbox"/>		MPS1600L-DIN	133	83	48	16	2
	5	<input checked="" type="checkbox"/>		MPS1600L-DIN-C	133	83	48	16	1
16.1	3	<input type="checkbox"/>		MPS1610S-DIN	123	73	48	18	2
	3	<input type="checkbox"/>		MPS1610S-DIN-C	123	73	48	18	1
	5	<input type="checkbox"/>		MPS1610L-DIN	143	93	48	18	2
	5	<input type="checkbox"/>		MPS1610L-DIN-C	143	93	48	18	1
16.2	3	<input type="checkbox"/>		MPS1620S-DIN	123	73	48	18	2
	3	<input type="checkbox"/>		MPS1620S-DIN-C	123	73	48	18	1
	5	<input type="checkbox"/>		MPS1620L-DIN	143	93	48	18	2
	5	<input type="checkbox"/>		MPS1620L-DIN-C	143	93	48	18	1
16.3	3	<input type="checkbox"/>		MPS1630S-DIN	123	73	48	18	2
	3	<input type="checkbox"/>		MPS1630S-DIN-C	123	73	48	18	1
	5	<input type="checkbox"/>		MPS1630L-DIN	143	93	48	18	2
	5	<input type="checkbox"/>		MPS1630L-DIN-C	143	93	48	18	1
16.4	3	<input type="checkbox"/>		MPS1640S-DIN	123	73	48	18	2
	3	<input type="checkbox"/>		MPS1640S-DIN-C	123	73	48	18	1
	5	<input type="checkbox"/>		MPS1640L-DIN	143	93	48	18	2
	5	<input type="checkbox"/>		MPS1640L-DIN-C	143	93	48	18	1
16.5	3	<input checked="" type="checkbox"/>		MPS1650S-DIN	123	73	48	18	2
	3	<input checked="" type="checkbox"/>		MPS1650S-DIN-C	123	73	48	18	1
	5	<input checked="" type="checkbox"/>		MPS1650L-DIN	143	93	48	18	2
	5	<input checked="" type="checkbox"/>		MPS1650L-DIN-C	143	93	48	18	1

Диам. сверла D1 (мм)	Глубина сверления (l/d)	Наличие		Обозначение	Размеры (мм)				Тип
		VP15TF			L1	L3	L9	D4	
16.6	3	<input type="checkbox"/>		MPS1660S-DIN	123	73	48	18	2
	3	<input type="checkbox"/>		MPS1660S-DIN-C	123	73	48	18	1
	5	<input type="checkbox"/>		MPS1660L-DIN	143	93	48	18	2
	5	<input type="checkbox"/>		MPS1660L-DIN-C	143	93	48	18	1
16.7	3	<input type="checkbox"/>		MPS1670S-DIN	123	73	48	18	2
	3	<input type="checkbox"/>		MPS1670S-DIN-C	123	73	48	18	1
	5	<input type="checkbox"/>		MPS1670L-DIN	143	93	48	18	2
	5	<input type="checkbox"/>		MPS1670L-DIN-C	143	93	48	18	1
16.8	3	<input type="checkbox"/>		MPS1680S-DIN	123	73	48	18	2
	3	<input type="checkbox"/>		MPS1680S-DIN-C	123	73	48	18	1
	5	<input type="checkbox"/>		MPS1680L-DIN	143	93	48	18	2
	5	<input type="checkbox"/>		MPS1680L-DIN-C	143	93	48	18	1
16.9	3	<input type="checkbox"/>		MPS1690S-DIN	123	73	48	18	2
	3	<input type="checkbox"/>		MPS1690S-DIN-C	123	73	48	18	1
	5	<input type="checkbox"/>		MPS1690L-DIN	143	93	48	18	2
	5	<input type="checkbox"/>		MPS1690L-DIN-C	143	93	48	18	1
17.0	3	<input checked="" type="checkbox"/>		MPS1700S-DIN	123	73	48	18	2
	3	<input checked="" type="checkbox"/>		MPS1700S-DIN-C	123	73	48	18	1
	5	<input checked="" type="checkbox"/>		MPS1700L-DIN	143	93	48	18	2
	5	<input checked="" type="checkbox"/>		MPS1700L-DIN-C	143	93	48	18	1
17.1	3	<input type="checkbox"/>		MPS1710S-DIN	123	73	48	18	2
	3	<input type="checkbox"/>		MPS1710S-DIN-C	123	73	48	18	1
	5	<input type="checkbox"/>		MPS1710L-DIN	143	93	48	18	2
	5	<input type="checkbox"/>		MPS1710L-DIN-C	143	93	48	18	1
17.2	3	<input type="checkbox"/>		MPS1720S-DIN	123	73	48	18	2
	3	<input type="checkbox"/>		MPS1720S-DIN-C	123	73	48	18	1
	5	<input type="checkbox"/>		MPS1720L-DIN	143	93	48	18	2
	5	<input type="checkbox"/>		MPS1720L-DIN-C	143	93	48	18	1
17.3	3	<input type="checkbox"/>		MPS1730S-DIN	123	73	48	18	2
	3	<input type="checkbox"/>		MPS1730S-DIN-C	123	73	48	18	1
	5	<input type="checkbox"/>		MPS1730L-DIN	143	93	48	18	2
	5	<input type="checkbox"/>		MPS1730L-DIN-C	143	93	48	18	1
17.4	3	<input type="checkbox"/>		MPS1740S-DIN	123	73	48	18	2
	3	<input type="checkbox"/>		MPS1740S-DIN-C	123	73	48	18	1
	5	<input type="checkbox"/>		MPS1740L-DIN	143	93	48	18	2
	5	<input type="checkbox"/>		MPS1740L-DIN-C	143	93	48	18	1
17.5	3	<input checked="" type="checkbox"/>		MPS1750S-DIN	123	73	48	18	2
	3	<input checked="" type="checkbox"/>		MPS1750S-DIN-C	123	73	48	18	1
	5	<input checked="" type="checkbox"/>		MPS1750L-DIN	143	93	48	18	2
	5	<input checked="" type="checkbox"/>		MPS1750L-DIN-C	143	93	48	18	1
17.6	3	<input type="checkbox"/>		MPS1760S-DIN	123	73	48	18	2
	3	<input type="checkbox"/>		MPS1760S-DIN-C	123	73	48	18	1
	5	<input type="checkbox"/>		MPS1760L-DIN	143	93	48	18	2
	5	<input type="checkbox"/>		MPS1760L-DIN-C	143	93	48	18	1
17.7	3	<input type="checkbox"/>		MPS1770S-DIN	123	73	48	18	2
	3	<input type="checkbox"/>		MPS1770S-DIN-C	123	73	48	18	1
	5	<input type="checkbox"/>		MPS1770L-DIN	143	93	48	18	2
	5	<input type="checkbox"/>		MPS1770L-DIN-C	143	93	48	18	1
17.8	3	<input type="checkbox"/>		MPS1780S-DIN	123	73	48	18	2
	3	<input type="checkbox"/>		MPS1780S-DIN-C	123	73	48	18	1
	5	<input type="checkbox"/>		MPS1780L-DIN	143	93	48	18	2
	5	<input type="checkbox"/>		MPS1780L-DIN-C	143	93	48	18	1
17.9	3	<input type="checkbox"/>		MPS1790S-DIN	123	73	48	18	2
	3	<input type="checkbox"/>		MPS1790S-DIN-C	123	73	48	18	1
	5	<input type="checkbox"/>		MPS1790L-DIN	143	93	48	18	2
	5	<input type="checkbox"/>		MPS1790L-DIN-C	143	93	48	18	1

● : Есть на складе. □ : Нет на складе, выпускается исключительно под заказ.

Диам. сверла D1 (мм)	Глубина сверления (l/d)	Наличие		Обозначение	Размеры (мм)				Тип
		VP15TF			L1	L3	L9	D4	
18.0	3	●		MPS1800S-DIN	123	73	48	18	2
	3	●		MPS1800S-DIN-C	123	73	48	18	1
	5	●		MPS1800L-DIN	143	93	48	18	2
	5	●		MPS1800L-DIN-C	143	93	48	18	1
18.1	3	□		MPS1810S-DIN	131	79	50	20	2
	3	□		MPS1810S-DIN-C	131	79	50	20	1
	5	□		MPS1810L-DIN	153	101	50	20	2
	5	□		MPS1810L-DIN-C	153	101	50	20	1
18.2	3	□		MPS1820S-DIN	131	79	50	20	2
	3	□		MPS1820S-DIN-C	131	79	50	20	1
	5	□		MPS1820L-DIN	153	101	50	20	2
	5	□		MPS1820L-DIN-C	153	101	50	20	1
18.3	3	□		MPS1830S-DIN	131	79	50	20	2
	3	□		MPS1830S-DIN-C	131	79	50	20	1
	5	□		MPS1830L-DIN	153	101	50	20	2
	5	□		MPS1830L-DIN-C	153	101	50	20	1
18.4	3	□		MPS1840S-DIN	131	79	50	20	2
	3	□		MPS1840S-DIN-C	131	79	50	20	1
	5	□		MPS1840L-DIN	153	101	50	20	2
	5	□		MPS1840L-DIN-C	153	101	50	20	1
18.5	3	●		MPS1850S-DIN	131	79	50	20	2
	3	●		MPS1850S-DIN-C	131	79	50	20	1
	5	●		MPS1850L-DIN	153	101	50	20	2
	5	●		MPS1850L-DIN-C	153	101	50	20	1
18.6	3	□		MPS1860S-DIN	131	79	50	20	2
	3	□		MPS1860S-DIN-C	131	79	50	20	1
	5	□		MPS1860L-DIN	153	101	50	20	2
	5	□		MPS1860L-DIN-C	153	101	50	20	1
18.7	3	□		MPS1870S-DIN	131	79	50	20	2
	3	□		MPS1870S-DIN-C	131	79	50	20	1
	5	□		MPS1870L-DIN	153	101	50	20	2
	5	□		MPS1870L-DIN-C	153	101	50	20	1
18.8	3	□		MPS1880S-DIN	131	79	50	20	2
	3	□		MPS1880S-DIN-C	131	79	50	20	1
	5	□		MPS1880L-DIN	153	101	50	20	2
	5	□		MPS1880L-DIN-C	153	101	50	20	1
18.9	3	□		MPS1890S-DIN	131	79	50	20	2
	3	□		MPS1890S-DIN-C	131	79	50	20	1
	5	□		MPS1890L-DIN	153	101	50	20	2
	5	□		MPS1890L-DIN-C	153	101	50	20	1
19.0	3	●		MPS1900S-DIN	131	79	50	20	2
	3	●		MPS1900S-DIN-C	131	79	50	20	1
	5	●		MPS1900L-DIN	153	101	50	20	2
	5	●		MPS1900L-DIN-C	153	101	50	20	1
19.1	3	□		MPS1910S-DIN	131	79	50	20	2
	3	□		MPS1910S-DIN-C	131	79	50	20	1
	5	□		MPS1910L-DIN	153	101	50	20	2
	5	□		MPS1910L-DIN-C	153	101	50	20	1
19.2	3	□		MPS1920S-DIN	131	79	50	20	2
	3	□		MPS1920S-DIN-C	131	79	50	20	1
	5	□		MPS1920L-DIN	153	101	50	20	2
	5	□		MPS1920L-DIN-C	153	101	50	20	1
19.3	3	□		MPS1930S-DIN	131	79	50	20	2
	3	□		MPS1930S-DIN-C	131	79	50	20	1
	5	□		MPS1930L-DIN	153	101	50	20	2
	5	□		MPS1930L-DIN-C	153	101	50	20	1

Диам. сверла D1 (мм)	Глубина сверления (l/d)	Наличие		Обозначение	Размеры (мм)				Тип
		VP15TF			L1	L3	L9	D4	
19.4	3	□		MPS1940S-DIN	131	79	50	20	2
	3	□		MPS1940S-DIN-C	131	79	50	20	1
	5	□		MPS1940L-DIN	153	101	50	20	2
	5	□		MPS1940L-DIN-C	153	101	50	20	1
19.5	3	●		MPS1950S-DIN	131	79	50	20	2
	3	□		MPS1950S-DIN-C	131	79	50	20	1
	5	●		MPS1950L-DIN	153	101	50	20	2
	5	●		MPS1950L-DIN-C	153	101	50	20	1
19.6	3	□		MPS1960S-DIN	131	79	50	20	2
	3	□		MPS1960S-DIN-C	131	79	50	20	1
	5	□		MPS1960L-DIN	153	101	50	20	2
	5	□		MPS1960L-DIN-C	153	101	50	20	1
19.7	3	□		MPS1970S-DIN	131	79	50	20	2
	3	□		MPS1970S-DIN-C	131	79	50	20	1
	5	□		MPS1970L-DIN	153	101	50	20	2
	5	□		MPS1970L-DIN-C	153	101	50	20	1
19.8	3	□		MPS1980S-DIN	131	79	50	20	2
	3	□		MPS1980S-DIN-C	131	79	50	20	1
	5	□		MPS1980L-DIN	153	101	50	20	2
	5	□		MPS1980L-DIN-C	153	101	50	20	1
19.9	3	□		MPS1990S-DIN	131	79	50	20	2
	3	□		MPS1990S-DIN-C	131	79	50	20	1
	5	□		MPS1990L-DIN	153	101	50	20	2
	5	□		MPS1990L-DIN-C	153	101	50	20	1
20.0	3	●		MPS2000S-DIN	131	79	50	20	2
	3	●		MPS2000S-DIN-C	131	79	50	20	1
	5	●		MPS2000L-DIN	153	101	50	20	2
	5	●		MPS2000L-DIN-C	153	101	50	20	1

# СВЕРЛЕНИЕ (МОНОЛИТНЫЕ ТВЕРДОСПЛАВНЫЕ СВЕРЛА)

**MSL**  
Стандартный тип

- Глубина сверления 20-30 l/d.
- Сверло MSL с 2 фасками для точного и надежного сверления.
- Все сверла имеют отверстия для внутреннего охлаждения.



Углеродистая сталь Легированная сталь	Закалённая сталь	Нержавеющая сталь	Чугун	Лёгкий сплав	Жаропрочные сплавы
○		○	○	○	○

	3.0 ≤ D1 ≤ 6.0	6.0 < D1 ≤ 10.0	10.0 < D1 ≤ 18.0	18.0 < D1 ≤ 20.0
	$\begin{matrix} 0 \\ -0.012 \end{matrix}$	$\begin{matrix} 0 \\ -0.015 \end{matrix}$	$\begin{matrix} 0 \\ -0.018 \end{matrix}$	$\begin{matrix} 0 \\ -0.021 \end{matrix}$
	$\begin{matrix} 0 \\ -0.008 \end{matrix}$	$\begin{matrix} 0 \\ -0.009 \end{matrix}$	$\begin{matrix} 0 \\ -0.011 \end{matrix}$	$\begin{matrix} 0 \\ -0.013 \end{matrix}$



## ● Цилиндрический хвостовик



MSL (l/d 20–30)

Диам. сверла D1 (мм)	Глубина сверления l/d	Наличие VP15TF	Обозначение	Размеры (мм)			
				L1	L3	L9	D4
3.0	20	●	MSL0300-L20C	110	70	36	6
	25	●	MSL0300-L25C	125	85	36	6
	30	●	MSL0300-L30C	140	100	36	6
3.1	20	●	MSL0310-L20C	122	82	36	6
	25	●	MSL0310-L25C	139	99	36	6
	30	●	MSL0310-L30C	157	117	36	6
3.2	20	●	MSL0320-L20C	122	82	36	6
	25	●	MSL0320-L25C	139	99	36	6
	30	●	MSL0320-L30C	157	117	36	6
3.3	20	●	MSL0330-L20C	122	82	36	6
	25	●	MSL0330-L25C	139	99	36	6
	30	●	MSL0330-L30C	157	117	36	6
3.4	20	●	MSL0340-L20C	122	82	36	6
	25	●	MSL0340-L25C	139	99	36	6
	30	●	MSL0340-L30C	157	117	36	6
3.5	20	●	MSL0350-L20C	122	82	36	6
	25	●	MSL0350-L25C	139	99	36	6
	30	●	MSL0350-L30C	157	117	36	6
3.6	20	●	MSL0360-L20C	133	93	36	6
	25	□	MSL0360-L25C	153	113	36	6
	30	●	MSL0360-L30C	173	133	36	6
3.7	20	●	MSL0370-L20C	133	93	36	6
	25	□	MSL0370-L25C	153	113	36	6
	30	●	MSL0370-L30C	173	133	36	6
3.8	20	●	MSL0380-L20C	133	93	36	6
	25	●	MSL0380-L25C	153	113	36	6
	30	●	MSL0380-L30C	173	133	36	6
3.9	20	●	MSL0390-L20C	133	93	36	6
	25	□	MSL0390-L25C	153	113	36	6
	30	●	MSL0390-L30C	173	133	36	6
4.0	20	●	MSL0400-L20C	133	93	36	6
	25	●	MSL0400-L25C	153	113	36	6
	30	●	MSL0400-L30C	173	133	36	6
4.1	20	●	MSL0410-L20C	145	105	36	6
	25	●	MSL0410-L25C	167	127	36	6
	30	●	MSL0410-L30C	190	150	36	6
4.2	20	●	MSL0420-L20C	145	105	36	6
	25	●	MSL0420-L25C	167	127	36	6
	30	●	MSL0420-L30C	190	150	36	6
4.3	20	●	MSL0430-L20C	145	105	36	6
	25	●	MSL0430-L25C	167	127	36	6
	30	●	MSL0430-L30C	190	150	36	6

Диам. сверла D1 (мм)	Глубина сверления l/d	Наличие VP15TF	Обозначение	Размеры (мм)			
				L1	L3	L9	D4
4.4	20	□	MSL0440-L20C	145	105	36	6
	25	□	MSL0440-L25C	167	127	36	6
	30	□	MSL0440-L30C	190	150	36	6
4.5	20	●	MSL0450-L20C	145	105	36	6
	25	●	MSL0450-L25C	167	127	36	6
	30	●	MSL0450-L30C	190	150	36	6
4.6	20	●	MSL0460-L20C	156	116	36	6
	25	●	MSL0460-L25C	181	141	36	6
	30	●	MSL0460-L30C	206	166	36	6
4.7	20	●	MSL0470-L20C	156	116	36	6
	25	●	MSL0470-L25C	181	141	36	6
	30	●	MSL0470-L30C	206	166	36	6
4.8	20	●	MSL0480-L20C	156	116	36	6
	25	●	MSL0480-L25C	181	141	36	6
	30	●	MSL0480-L30C	206	166	36	6
4.9	20	□	MSL0490-L20C	156	116	36	6
	25	●	MSL0490-L25C	181	141	36	6
	30	●	MSL0490-L30C	206	166	36	6
5.0	20	●	MSL0500-L20C	156	116	36	6
	25	●	MSL0500-L25C	181	141	36	6
	30	●	MSL0500-L30C	206	166	36	6
5.1	20	●	MSL0510-L20C	168	128	36	6
	25	●	MSL0510-L25C	195	155	36	6
	30	●	MSL0510-L30C	223	183	36	6
5.2	20	●	MSL0520-L20C	168	128	36	6
	25	●	MSL0520-L25C	195	155	36	6
	30	●	MSL0520-L30C	223	183	36	6
5.3	20	□	MSL0530-L20C	168	128	36	6
	25	●	MSL0530-L25C	195	155	36	6
	30	□	MSL0530-L30C	223	183	36	6
5.4	20	●	MSL0540-L20C	168	128	36	6
	25	□	MSL0540-L25C	195	155	36	6
	30	□	MSL0540-L30C	223	183	36	6
5.5	20	●	MSL0550-L20C	168	128	36	6
	25	●	MSL0550-L25C	195	155	36	6
	30	●	MSL0550-L30C	223	183	36	6
5.6	20	□	MSL0560-L20C	179	139	36	6
	25	□	MSL0560-L25C	209	169	36	6
	30	●	MSL0560-L30C	239	199	36	6
5.7	20	□	MSL0570-L20C	179	139	36	6
	25	●	MSL0570-L25C	209	169	36	6
	30	□	MSL0570-L30C	239	199	36	6

● : Есть на складе. □ : Нет на складе, выпускается исключительно под заказ.

Диам. сверла D1 (мм)	Глубина сверления (l/d)	Наличие		Обозначение	Размеры (мм)			
		VP15TF			L1	L3	L9	D4
5.8	20	●		MSL0580-L20C	179	139	36	6
	25	□		MSL0580-L25C	209	169	36	6
	30	●		MSL0580-L30C	239	199	36	6
5.9	20	●		MSL0590-L20C	179	139	36	6
	25	●		MSL0590-L25C	209	169	36	6
	30	□		MSL0590-L30C	239	199	36	6
6.0	20	●		MSL0600-L20C	179	139	36	6
	25	●		MSL0600-L25C	209	169	36	6
	30	●		MSL0600-L30C	239	199	36	6
6.1	20	●		MSL0610-L20C	191	151	36	8
	25	●		MSL0610-L25C	223	183	36	8
	30	●		MSL0610-L30C	256	216	36	8
6.2	20	●		MSL0620-L20C	191	151	36	8
	25	□		MSL0620-L25C	223	183	36	8
	30	□		MSL0620-L30C	256	216	36	8
6.3	20	●		MSL0630-L20C	191	151	36	8
	25	□		MSL0630-L25C	223	183	36	8
	30	●		MSL0630-L30C	256	216	36	8
6.4	20	●		MSL0640-L20C	191	151	36	8
	25	●		MSL0640-L25C	223	183	36	8
	30	●		MSL0640-L30C	256	216	36	8
6.5	20	●		MSL0650-L20C	191	151	36	8
	25	●		MSL0650-L25C	223	183	36	8
	30	●		MSL0650-L30C	256	216	36	8
6.6	20	□		MSL0660-L20C	202	162	36	8
	25	●		MSL0660-L25C	237	197	36	8
	30	●		MSL0660-L30C	272	232	36	8
6.7	20	□		MSL0670-L20C	202	162	36	8
	25	□		MSL0670-L25C	237	197	36	8
	30	●		MSL0670-L30C	272	232	36	8
6.8	20	●		MSL0680-L20C	202	162	36	8
	25	●		MSL0680-L25C	237	197	36	8
	30	●		MSL0680-L30C	272	232	36	8
6.9	20	●		MSL0690-L20C	202	162	36	8
	25	●		MSL0690-L25C	237	197	36	8
	30	●		MSL0690-L30C	272	232	36	8
7.0	20	●		MSL0700-L20C	202	162	36	8
	25	●		MSL0700-L25C	237	197	36	8
	30	●		MSL0700-L30C	272	232	36	8
7.1	20	●		MSL0710-L20C	214	174	36	8
	25	●		MSL0710-L25C	251	211	36	8
	30	□		MSL0710-L30C	289	249	36	8
7.2	20	□		MSL0720-L20C	214	174	36	8
	25	□		MSL0720-L25C	251	211	36	8
	30	□		MSL0720-L30C	289	249	36	8
7.3	20	□		MSL0730-L20C	214	174	36	8
	25	□		MSL0730-L25C	251	211	36	8
	30	□		MSL0730-L30C	289	249	36	8
7.4	20	□		MSL0740-L20C	214	174	36	8
	25	□		MSL0740-L25C	251	211	36	8
	30	□		MSL0740-L30C	289	249	36	8
7.5	20	●		MSL0750-L20C	214	174	36	8
	25	●		MSL0750-L25C	251	211	36	8
	30	●		MSL0750-L30C	289	249	36	8

Диам. сверла D1 (мм)	Глубина сверления (l/d)	Наличие		Обозначение	Размеры (мм)			
		VP15TF			L1	L3	L9	D4
7.6	20	□		MSL0760-L20C	225	185	36	8
	25	●		MSL0760-L25C	265	225	36	8
	30	□		MSL0760-L30C	305	265	36	8
7.7	20	□		MSL0770-L20C	225	185	36	8
	25	●		MSL0770-L25C	265	225	36	8
	30	□		MSL0770-L30C	305	265	36	8
7.8	20	□		MSL0780-L20C	225	185	36	8
	25	□		MSL0780-L25C	265	225	36	8
	30	●		MSL0780-L30C	305	265	36	8
7.9	20	□		MSL0790-L20C	225	185	36	8
	25	●		MSL0790-L25C	265	225	36	8
	30	□		MSL0790-L30C	305	265	36	8
8.0	20	●		MSL0800-L20C	225	185	36	8
	25	●		MSL0800-L25C	265	225	36	8
	30	●		MSL0800-L30C	305	265	36	8
8.1	20	●		MSL0810-L20C	241	197	40	10
	25	□		MSL0810-L25C	283	239	40	10
	30	□		MSL0810-L30C	326	282	40	10
8.2	20	●		MSL0820-L20C	241	197	40	10
	25	□		MSL0820-L25C	283	239	40	10
	30	□		MSL0820-L30C	326	282	40	10
8.3	20	□		MSL0830-L20C	241	197	40	10
	25	□		MSL0830-L25C	283	239	40	10
	30	□		MSL0830-L30C	326	282	40	10
8.4	20	□		MSL0840-L20C	241	197	40	10
	25	□		MSL0840-L25C	283	239	40	10
	30	□		MSL0840-L30C	326	282	40	10
8.5	20	●		MSL0850-L20C	241	197	40	10
	25	●		MSL0850-L25C	283	239	40	10
	30	●		MSL0850-L30C	326	282	40	10
8.6	20	□		MSL0860-L20C	252	208	40	10
	25	●		MSL0860-L25C	297	253	40	10
	30	●		MSL0860-L30C	342	298	40	10
8.7	20	□		MSL0870-L20C	252	208	40	10
	25	●		MSL0870-L25C	297	253	40	10
	30	□		MSL0870-L30C	342	298	40	10
8.8	20	●		MSL0880-L20C	252	208	40	10
	25	●		MSL0880-L25C	297	253	40	10
	30	●		MSL0880-L30C	342	298	40	10
8.9	20	□		MSL0890-L20C	252	208	40	10
	25	□		MSL0890-L25C	297	253	40	10
	30	□		MSL0890-L30C	342	298	40	10
9.0	20	●		MSL0900-L20C	252	208	40	10
	25	●		MSL0900-L25C	297	253	40	10
	30	●		MSL0900-L30C	342	298	40	10
9.1	20	□		MSL0910-L20C	265	221	40	10
	25	□		MSL0910-L25C	312	268	40	10
	30	□		MSL0910-L30C	360	316	40	10
9.2	20	□		MSL0920-L20C	265	221	40	10
	25	□		MSL0920-L25C	312	268	40	10
	30	□		MSL0920-L30C	360	316	40	10
9.3	20	□		MSL0930-L20C	265	221	40	10
	25	□		MSL0930-L25C	312	268	40	10
	30	□		MSL0930-L30C	360	316	40	10

# СВЕРЛЕНИЕ (МОНОЛИТНЫЕ ТВЕРДОСПЛАВНЫЕ СВЕРЛА)

**MSL**  
Стандартный тип

ТВЕРДЫЙ  
СПЛАВ

Диам. сверла D1 (мм)	Глубина сверления (l/d)	Наличие		Обозначение	Размеры (мм)			
		VP15TF			L1	L3	L9	D4
9.4	20	<input type="checkbox"/>		MSL0940-L20C	265	221	40	10
	25	<input type="checkbox"/>		MSL0940-L25C	312	268	40	10
	30	<input type="checkbox"/>		MSL0940-L30C	360	316	40	10
9.5	20	<input checked="" type="checkbox"/>		MSL0950-L20C	265	221	40	10
	25	<input checked="" type="checkbox"/>		MSL0950-L25C	312	268	40	10
	30	<input checked="" type="checkbox"/>		MSL0950-L30C	360	316	40	10
9.6	20	<input type="checkbox"/>		MSL0960-L20C	276	232	40	10
	25	<input type="checkbox"/>		MSL0960-L25C	326	282	40	10
	30	<input type="checkbox"/>		MSL0960-L30C	376	332	40	10
9.7	20	<input type="checkbox"/>		MSL0970-L20C	276	232	40	10
	25	<input type="checkbox"/>		MSL0970-L25C	326	282	40	10
	30	<input type="checkbox"/>		MSL0970-L30C	376	332	40	10
9.8	20	<input checked="" type="checkbox"/>		MSL0980-L20C	276	232	40	10
	25	<input type="checkbox"/>		MSL0980-L25C	326	282	40	10
	30	<input checked="" type="checkbox"/>		MSL0980-L30C	376	332	40	10
9.9	20	<input type="checkbox"/>		MSL0990-L20C	276	232	40	10
	25	<input type="checkbox"/>		MSL0990-L25C	326	282	40	10
	30	<input type="checkbox"/>		MSL0990-L30C	376	332	40	10
10.0	20	<input checked="" type="checkbox"/>		MSL1000-L20C	276	232	40	10
	25	<input checked="" type="checkbox"/>		MSL1000-L25C	326	282	40	10
	30	<input checked="" type="checkbox"/>		MSL1000-L30C	376	332	40	10
10.1	20	<input checked="" type="checkbox"/>		MSL1010-L20C	293	244	45	12
	25	<input type="checkbox"/>		MSL1010-L25C	345	296	45	12
10.2	20	<input checked="" type="checkbox"/>		MSL1020-L20C	293	244	45	12
	25	<input type="checkbox"/>		MSL1020-L25C	345	296	45	12
10.3	20	<input type="checkbox"/>		MSL1030-L20C	293	244	45	12
	25	<input type="checkbox"/>		MSL1030-L25C	345	296	45	12
10.4	20	<input type="checkbox"/>		MSL1040-L20C	293	244	45	12
	25	<input type="checkbox"/>		MSL1040-L25C	345	296	45	12
10.5	20	<input checked="" type="checkbox"/>		MSL1050-L20C	293	244	45	12
	25	<input checked="" type="checkbox"/>		MSL1050-L25C	345	296	45	12
10.6	20	<input type="checkbox"/>		MSL1060-L20C	304	255	45	12
	25	<input type="checkbox"/>		MSL1060-L25C	359	310	45	12
10.7	20	<input type="checkbox"/>		MSL1070-L20C	304	255	45	12
	25	<input type="checkbox"/>		MSL1070-L25C	359	310	45	12
10.8	20	<input type="checkbox"/>		MSL1080-L20C	304	255	45	12
	25	<input type="checkbox"/>		MSL1080-L25C	359	310	45	12
10.9	20	<input type="checkbox"/>		MSL1090-L20C	304	255	45	12
	25	<input type="checkbox"/>		MSL1090-L25C	359	310	45	12
11.0	20	<input checked="" type="checkbox"/>		MSL1100-L20C	304	255	45	12
	25	<input checked="" type="checkbox"/>		MSL1100-L25C	359	310	45	12
11.1	20	<input type="checkbox"/>		MSL1110-L20C	316	267	45	12
	25	<input type="checkbox"/>		MSL1110-L25C	373	324	45	12
11.2	20	<input type="checkbox"/>		MSL1120-L20C	316	267	45	12
	25	<input type="checkbox"/>		MSL1120-L25C	373	324	45	12
11.3	20	<input type="checkbox"/>		MSL1130-L20C	316	267	45	12
	25	<input type="checkbox"/>		MSL1130-L25C	373	324	45	12
11.4	20	<input type="checkbox"/>		MSL1140-L20C	316	267	45	12
	25	<input type="checkbox"/>		MSL1140-L25C	373	324	45	12
11.5	20	<input checked="" type="checkbox"/>		MSL1150-L20C	316	267	45	12
	25	<input checked="" type="checkbox"/>		MSL1150-L25C	373	324	45	12
11.6	20	<input type="checkbox"/>		MSL1160-L20C	327	278	45	12
	25	<input type="checkbox"/>		MSL1160-L25C	387	338	45	12

Диам. сверла D1 (мм)	Глубина сверления (l/d)	Наличие		Обозначение	Размеры (мм)			
		VP15TF			L1	L3	L9	D4
11.7	20	<input type="checkbox"/>		MSL1170-L20C	327	278	45	12
	25	<input type="checkbox"/>		MSL1170-L25C	387	338	45	12
11.8	20	<input type="checkbox"/>		MSL1180-L20C	327	278	45	12
	25	<input type="checkbox"/>		MSL1180-L25C	387	338	45	12
11.9	20	<input type="checkbox"/>		MSL1190-L20C	327	278	45	12
	25	<input type="checkbox"/>		MSL1190-L25C	387	338	45	12
12.0	20	<input checked="" type="checkbox"/>		MSL1200-L20C	327	278	45	12
	25	<input checked="" type="checkbox"/>		MSL1200-L25C	387	338	45	12
12.1	20	<input type="checkbox"/>		MSL1210-L20C	339	290	45	14
	25	<input type="checkbox"/>		MSL1210-L25C	399	341	45	14
12.2	20	<input type="checkbox"/>		MSL1220-L20C	339	290	45	14
	25	<input type="checkbox"/>		MSL1220-L25C	399	341	45	14
12.3	20	<input type="checkbox"/>		MSL1230-L20C	339	290	45	14
	25	<input type="checkbox"/>		MSL1230-L25C	399	341	45	14
12.4	20	<input type="checkbox"/>		MSL1240-L20C	339	290	45	14
	25	<input type="checkbox"/>		MSL1240-L25C	399	341	45	14
12.5	20	<input type="checkbox"/>		MSL1250-L20C	339	290	45	14
	25	<input type="checkbox"/>		MSL1250-L25C	399	341	45	14
12.6	20	<input type="checkbox"/>		MSL1260-L20C	350	301	45	14
	25	<input type="checkbox"/>		MSL1260-L25C	410	353	45	14
12.7	20	<input type="checkbox"/>		MSL1270-L20C	350	301	45	14
	25	<input type="checkbox"/>		MSL1270-L25C	410	353	45	14
12.8	20	<input type="checkbox"/>		MSL1280-L20C	350	301	45	14
	25	<input type="checkbox"/>		MSL1280-L25C	410	353	45	14
12.9	20	<input type="checkbox"/>		MSL1290-L20C	350	301	45	14
	25	<input type="checkbox"/>		MSL1290-L25C	410	353	45	14
13.0	20	<input checked="" type="checkbox"/>		MSL1300-L20C	350	301	45	14
	25	<input type="checkbox"/>		MSL1300-L25C	410	353	45	14
13.1	20	<input type="checkbox"/>		MSL1310-L20C	362	313	45	14
	25	<input type="checkbox"/>		MSL1310-L25C	422	365	45	14
13.2	20	<input type="checkbox"/>		MSL1320-L20C	362	313	45	14
	25	<input type="checkbox"/>		MSL1320-L25C	422	365	45	14
13.3	20	<input type="checkbox"/>		MSL1330-L20C	362	313	45	14
	25	<input type="checkbox"/>		MSL1330-L25C	422	365	45	14
13.4	20	<input type="checkbox"/>		MSL1340-L20C	362	313	45	14
	25	<input type="checkbox"/>		MSL1340-L25C	422	365	45	14
13.5	20	<input type="checkbox"/>		MSL1350-L20C	362	313	45	14
	25	<input type="checkbox"/>		MSL1350-L25C	422	365	45	14
13.6	20	<input type="checkbox"/>		MSL1360-L20C	373	324	45	14
	25	<input type="checkbox"/>		MSL1360-L25C	433	376	45	14
13.7	20	<input type="checkbox"/>		MSL1370-L20C	373	324	45	14
	25	<input type="checkbox"/>		MSL1370-L25C	433	376	45	14
13.8	20	<input type="checkbox"/>		MSL1380-L20C	373	324	45	14
	25	<input type="checkbox"/>		MSL1380-L25C	433	376	45	14
13.9	20	<input type="checkbox"/>		MSL1390-L20C	373	324	45	14
	25	<input type="checkbox"/>		MSL1390-L25C	433	376	45	14
14.0	20	<input checked="" type="checkbox"/>		MSL1400-L20C	373	324	45	14
	25	<input type="checkbox"/>		MSL1400-L25C	433	376	45	14

● : Есть на складе. □ : Нет на складе, выпускается исключительно под заказ.

## РЕКОМЕНДУЕМЫЕ РЕЖИМЫ РЕЗАНИЯ

### ● MPS СВЕРЛА (3xD, 5xD, 8xD, 12xD)

Обрабатываемый материал	Диаметр сверла Условия Твердость	φ 3.0—φ 6.0		φ 6.0—φ 10.0		φ 10.0—φ 14.0		φ 14.0—φ 20.0	
		Скорость резания (м/мин)	Подача (мм/об)	Скорость резания (м/мин)	Подача (мм/об)	Скорость резания (м/мин)	Подача (мм/об)	Скорость резания (м/мин)	Подача (мм/об)
<b>P</b> Малоуглеродистые стали	≤180НВ	110 (50—120)	0.20 (0.15—0.25)	130 (80—140)	0.25 (0.20—0.35)	150 (90—170)	0.30 (0.20—0.40)	160 (100—180)	0.35 (0.20—0.40)
	180—280НВ	90 (50—100)	0.20 (0.15—0.25)	110 (70—120)	0.25 (0.20—0.35)	130 (80—140)	0.25 (0.20—0.40)	140 (100—150)	0.30 (0.20—0.40)
	280—350НВ	80 (40—90)	0.20 (0.15—0.30)	90 (60—110)	0.25 (0.15—0.30)	110 (70—130)	0.25 (0.15—0.40)	120 (90—140)	0.30 (0.20—0.40)
<b>M</b> Нержавеющая сталь	≤200НВ	50 (20—100)	0.10 (0.05—0.15)	60 (40—120)	0.20 (0.10—0.25)	70 (50—120)	0.25 (0.15—0.30)	80 (60—120)	0.25 (0.15—0.30)
<b>K</b> Чугун	Предел прочности ≤350МПа	100 (70—120)	0.25 (0.15—0.30)	130 (100—140)	0.30 (0.20—0.35)	150 (110—160)	0.35 (0.25—0.40)	160 (120—170)	0.35 (0.25—0.40)
	Предел прочности ≤450МПа	60 (30—80)	0.20 (0.15—0.25)	70 (40—90)	0.20 (0.15—0.30)	90 (50—110)	0.25 (0.20—0.40)	100 (60—110)	0.3 (0.20—0.40)
<b>S</b> Жаропрочные сплавы	—	20 (10—25)	0.10 (0.05—0.15)	25 (15—30)	0.12 (0.05—0.15)	25 (15—30)	0.15 (0.10—0.20)	30 (25—35)	0.15 (0.10—0.20)

### ● MPS СВЕРЛА (l/d=15—30), MSL СВЕРЛА (l/d=20—30)

Обрабатываемый материал	Диаметр сверла Условия Твердость	φ 3.0—φ 6.0		φ 6.0—φ 10.0		φ 10.0—φ 14.0	
		Скорость резания (м/мин)	Подача (мм/об)	Скорость резания (м/мин)	Подача (мм/об)	Скорость резания (м/мин)	Подача (мм/об)
<b>P</b> Малоуглеродистые стали	≤180НВ	85 (35—100)	0.20 (0.15—0.25)	85 (45—120)	0.25 (0.15—0.35)	90 (55—120)	0.30 (0.20—0.35)
	180—280НВ	80 (40—95)	0.20 (0.15—0.25)	90 (50—120)	0.25 (0.20—0.35)	90 (60—130)	0.30 (0.15—0.35)
	280—350НВ	75 (35—80)	0.15 (0.15—0.20)	80 (45—115)	0.20 (0.15—0.25)	85 (55—115)	0.25 (0.15—0.30)
<b>M</b> Нержавеющая сталь	≤200НВ	50 (20—80)	0.10 (0.05—0.15)	60 (20—90)	0.12 (0.05—0.15)	70 (20—90)	0.15 (0.10—0.20)
<b>K</b> Чугун	Предел прочности ≤350МПа	70 (40—85)	0.25 (0.15—0.30)	75 (50—90)	0.30 (0.20—0.35)	80 (50—95)	0.35 (0.20—0.40)
	Предел прочности ≤450МПа	65 (35—80)	0.20 (0.15—0.25)	70 (45—85)	0.25 (0.15—0.30)	75 (45—90)	0.30 (0.20—0.35)
<b>S</b> Жаропрочные сплавы	—	20 (10—25)	0.10 (0.05—0.15)	25 (15—30)	0.12 (0.05—0.15)	25 (15—30)	0.15 (0.10—0.20)

### ● MPS СВЕРЛА (l/d=35—40)

Обрабатываемый материал	Диаметр сверла Условия Твердость	φ 3.0—φ 4.0		φ 5.0—φ 6.0		φ 6.0—φ 9.0	
		Скорость резания (м/мин)	Подача (мм/об)	Скорость резания (м/мин)	Подача (мм/об)	Скорость резания (м/мин)	Подача (мм/об)
<b>P</b> Малоуглеродистые стали	≤180НВ	60 (50—70)	0.18 (0.13—0.20)	70 (55—80)	0.20 (0.15—0.23)	75 (60—85)	0.25 (0.18—0.28)
	180—280НВ	55 (40—65)	0.15 (0.10—0.18)	65 (45—75)	0.18 (0.13—0.22)	70 (55—80)	0.23 (0.15—0.25)
	280—350НВ	50 (40—60)	0.12 (0.08—0.15)	55 (40—65)	0.17 (0.13—0.20)	60 (40—75)	0.20 (0.15—0.23)
<b>M</b> Нержавеющая сталь	≤200НВ	35 (30—45)	0.10 (0.07—0.15)	40 (30—50)	0.12 (0.08—0.15)	45 (30—60)	0.15 (0.13—0.20)
<b>K</b> Чугун	Предел прочности ≤350МПа	55 (35—70)	0.15 (0.10—0.20)	60 (40—65)	0.20 (0.15—0.23)	60 (45—70)	0.23 (0.18—0.28)
	Предел прочности ≤450МПа	45 (30—60)	0.12 (0.08—0.15)	50 (40—60)	0.17 (0.13—0.20)	55 (40—65)	0.20 (0.15—0.23)
<b>S</b> Жаропрочные сплавы	—	15 (10—25)	0.07 (0.05—0.10)	20 (10—25)	0.07 (0.05—0.10)	20 (10—25)	0.10 (0.06—0.12)

Режимы резания могут быть изменены. Используйте приведенные в таблице значения как первоначальные и корректируйте значения в зависимости от условий обработки. Для сверл длиной выше l/d=10 рекомендуется просверлить направляющее отверстие.

### РУКОВОДСТВО ПО ИСПОЛЬЗОВАНИЮ СВЁРЛ ДЛИННЫХ СЕРИЙ

#### ● Сделать глухое отверстие

##### ■ 1. Выполнить направляющее отверстие



- ① Для выполнения направляющего отверстия мы рекомендуем использовать сверла фирмы Mitsubishi типа MPS.
- ② Для обеспечения безупречного выполнения сверления, точно выполняйте направляющее отверстие.
- ③ Направляющее отверстие : мин.  $1 \times D$  или глубже.  
(Выберите глубину направляющего отверстия, соответствующую длине сверхдлинного сверла.)

##### ■ 2. Предварительная обработка при помощи длинного сверла.

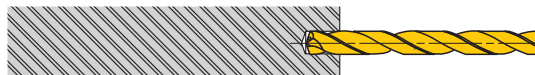

- ① Вход в направляющее отверстие с малой частотой вращения.  
(Скорость резания 20–30 м/мин, подача 0.2–0.3 мм/об)
- ② Остановить сверло для глубоких отверстий 1–3 мм до достижения дна направляющего отверстия.

##### ■ 3. сверление глубокого отверстия

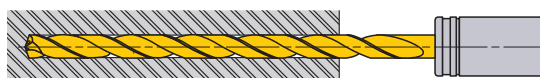

- ① Увеличьте частоту вращения и подачу за цикл и просверлите до желаемой глубины.

##### ■ 4. Выведите сверло

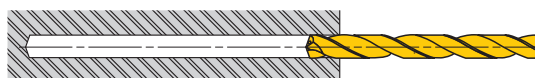

- ① После просверливания, примерно на 1–2 мм до конца отверстия, уменьшить скорость резания (скорость резания 20–30 м/мин.)
- ② Вынуть сверло примерно до глубины направляющего отверстия ( $V_f=3000$ мм/мин.)
- ③ Выведите сверло из направляющего отверстия с уменьшенной частотой вращения ( $n=300$ ,  $V_f=3000$ мм/мин)

#### ● Отверстия на изогнутых заготовках

##### ■ 1. Плоское фрезерование

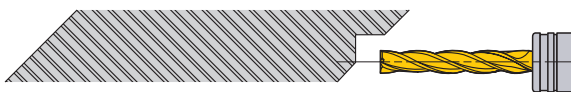

- ① Фрезеруйте плоскую поверхность в заготовке и установите фрезу с тем же диаметром, что и диаметр желаемого отверстия.

##### ■ 2. Выполнить направляющее отверстие



- ① Для выполнения направляющего отверстия мы рекомендуем использовать сверла фирмы Mitsubishi типа MPS.
- ② Для обеспечения безупречного выполнения сверления, точно выполняйте направляющее отверстие.
- ③ Направляющее отверстие : мин.  $1 \times D$  или глубже.  
(Выберите глубину направляющего отверстия, соответствующую длине сверхдлинного сверла.)

##### ■ 3. Предварительная обработка при помощи длинного сверла.

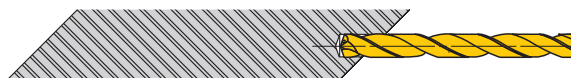

- ① Вход в направляющее отверстие с малой частотой вращения.  
(Скорость резания 20–30 м/мин, подача 0.2–0.3 мм/об)
- ② Остановить сверло для глубоких отверстий 1–3 мм до достижения дна направляющего отверстия.

##### ■ 4. сверление глубокого отверстия

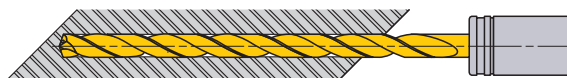

- ① Увеличьте частоту вращения и подачу за цикл и просверлите до желаемой глубины.

##### ■ 5. Сквозные отверстия



- ① При выходе из заготовки режущая кромка сверла может обломиться.
- ② Уменьшите подачу до  $V_f=0.05$ мм–0.1мм/об.

##### ■ 6. Отвод сверла из отверстия

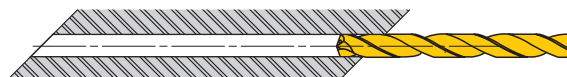

- ① Выведите сверло из направляющего отверстия до глубины начальной точки с подачей 3000мм/мин.
- ② Обработайте отверстие со скоростью резания 20–30м/мин и подачей 0.2–0.3мм/об.

# MICRO-MGS

- Возможно глубокое сверление отверстий малого диаметра.
- Практически полное отсутствие радиального биения обеспечивает высокую точность сверления.

ТВЕРДЫЙ СПЛАВ

Углеродистая сталь Легированная сталь	Закалённая сталь	Нержавеющая сталь	Чугун	Лёгкий сплав	Жаропрочные сплавы
○	○	○	○	○	○

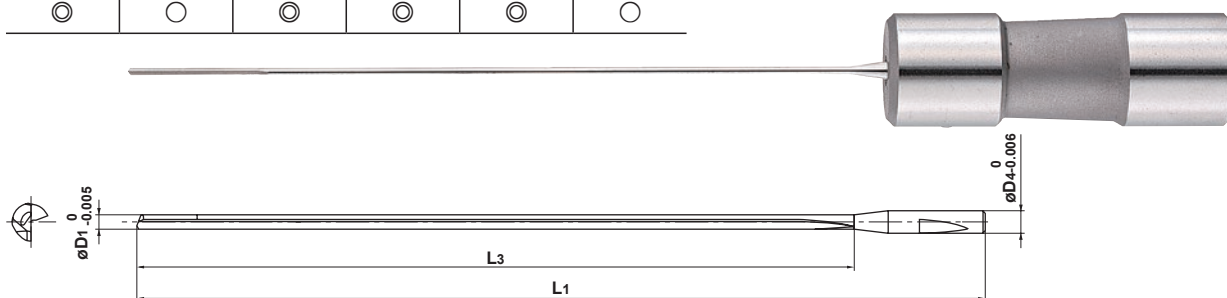

(Примечание) Сверла MGS предназначены для использования с термоматрицами.

Диам. сверла D1 (мм)	Глубина сверления (l/d)	Охлаждение (Внут./Нар.)	Наличие HT10	Обозначение	Размеры (мм)		
					L3	L1	D4
0.7	50	Внут.	★	MGS0070L040B	40	80	3
	80	Внут.	★	0070L060B	60	100	3
0.8	45	Внут.	★	0080L040B	40	80	3
	70	Внут.	★	0080L060B	60	100	3
0.9	40	Внут.	★	0090L040B	40	80	3
	60	Внут.	★	0090L060B	60	100	3
1.0	35	Внут.	★	0100L040B	40	80	3
	55	Внут.	★	0100L060B	60	100	3
	75	Внут.	★	0100L080B	80	120	3
1.1	30	Внут.	★	0110L040B	40	80	3
	50	Внут.	★	0110L060B	60	100	3
	65	Внут.	★	0110L080B	80	120	3
1.2	30	Внут.	★	0120L040B	40	80	3
	45	Внут.	★	0120L060B	60	100	3
	60	Внут.	★	0120L080B	80	120	3
1.3	40	Внут.	★	0130L060B	60	100	3
	55	Внут.	★	0130L080B	80	120	3
	70	Внут.	★	0130L100B	100	140	3
1.4	35	Внут.	★	0140L060B	60	100	3
	50	Внут.	★	0140L080B	80	120	3
	65	Внут.	★	0140L100B	100	140	3
1.5	35	Внут.	★	0150L060B	60	100	3
	50	Внут.	★	0150L080B	80	120	3
	60	Внут.	★	0150L100B	100	140	3
1.6	30	Внут.	★	0160L060B	60	100	3
	45	Внут.	★	0160L080B	80	120	3
	55	Внут.	★	0160L100B	100	140	3
1.7	30	Внут.	★	0170L060B	60	100	3
	40	Внут.	★	0170L080B	80	120	3
	55	Внут.	★	0170L100B	100	140	3

Диам. сверла D1 (мм)	Глубина сверления (l/d)	Охлаждение (Внут./Нар.)	Наличие HT10	Обозначение	Размеры (мм)		
					L3	L1	D4
1.8	30	Внут.	★	MGS0180L060B	60	100	3
	40	Внут.	★	0180L080B	80	120	3
	50	Внут.	★	0180L100B	100	140	3
1.9	25	Внут.	★	0190L060B	60	100	3
	35	Внут.	★	0190L080B	80	120	3
	45	Внут.	★	0190L100B	100	140	3
2.0	25	Внут.	★	0200L060B	60	100	3
	35	Внут.	★	0200L080B	80	120	3
	45	Внут.	★	0200L100B	100	140	3
2.1	35	Внут.	★	0210L080B	80	120	3
	40	Внут.	★	0210L100B	100	140	3
2.2	30	Внут.	★	0220L080B	80	120	3
	40	Внут.	★	0220L100B	100	140	3
2.3	30	Внут.	★	0230L080B	80	120	3
	40	Внут.	★	0230L100B	100	140	3
2.4	30	Внут.	★	0240L080B	80	120	3
	35	Внут.	★	0240L100B	100	140	3
2.5	25	Внут.	★	0250L080B	80	120	3
	35	Внут.	★	0250L100B	100	140	3
2.6	25	Внут.	★	0260L080B	80	120	3
	35	Внут.	★	0260L100B	100	140	3
2.7	25	Внут.	★	0270L080B	80	120	3
	30	Внут.	★	0270L100B	100	140	3
2.8	25	Внут.	★	0280L080B	80	120	3
	30	Внут.	★	0280L100B	100	140	3
2.9	20	Внут.	★	0290L080B	80	120	3
	30	Внут.	★	0290L100B	100	140	3
3.0	20	Внут.	★	0300L080B	80	120	3
	30	Внут.	★	0300L100B	100	140	3

(Примечание) Если Вам необходимы сверла с покрытием, пожалуйста, свяжитесь с нами. (**VP**, **GP** и **UP** твердый сплав с покрытием).

СВЕРЛЕНИЕ

★ : Со склада в Японии.

РЕЖИМЫ РЕЗАНИЯ > L056  
ТЕХНИЧЕСКИЕ ДАННЫЕ > N001

# СВЕРЛЕНИЕ (МОНОЛИТНЫЕ ТВЕРДОСПЛАВНЫЕ СВЕРЛА)

## MICRO-MGS

- Возможно глубокое сверление отверстий малого диаметра.
- Практически полное отсутствие радиального биения обеспечивает высокую точность сверления.

### ОТВЕРТКА

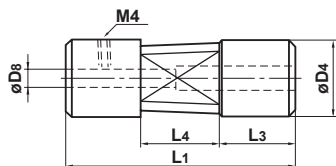

### Когда используется направляющая

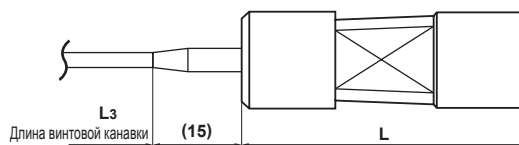

Обозначение	Наличие	Размеры (мм)					Винт установочный	Ключ
		D4	D8	L1	L3	L4		
<b>MGD38</b>	★	12.7	3.0	38.1	12.6	12.7	HSS04004	HKY20F
<b>MGD70</b>	★	12.7	3.0	70.0	25.0	20.0	HSS04004	HKY20F

### РЕКОМЕНДУЕМЫЕ РЕЖИМЫ РЕЗАНИЯ

Обработываемый материал	Не растворимая в воде СОЖ				Не растворимая в воде СОЖ				
	Скорость резания (м/мин)	Частота вращения (мин <sup>-1</sup> )	Подача (мин.—макс.) (мм/об)		Скорость резания (м/мин)	Частота вращения (мин <sup>-1</sup> )	Подача (мин.—макс.) (мм/об)		
Малоуглеродистые стали (≤180НВ) Ск10					Углеродистая сталь Легированная сталь (180—280НВ) Ск45, 42CrMo4				
	0.8	50	19800	0.01 (0.005—0.016)	195	40	15900	0.01 (0.005—0.016)	155
	1.0	50	15900	0.01 (0.007—0.020)	155	40	12700	0.01 (0.007—0.020)	125
	1.2	60	15900	0.015 (0.008—0.024)	235	50	13200	0.015 (0.008—0.024)	195
	1.6	60	11900	0.02 (0.011—0.032)	235	50	9900	0.02 (0.011—0.032)	195
	2.0	60	9500	0.025 (0.013—0.040)	235	50	7900	0.025 (0.013—0.040)	195
	2.5	70	8900	0.03 (0.017—0.050)	265	60	7600	0.03 (0.017—0.050)	225
	3.0	70	7400	0.04 (0.020—0.060)	295	60	6300	0.04 (0.020—0.060)	250
Углеродистая сталь Легированная сталь (280—350НВ) 36CrNiMo4					Аустенитная нержавеющая сталь (≤200НВ) Х5CrNi1810, Х5CrNiMo17-12-2				
	0.8	30	11900	0.005 (0.004—0.005)	55	30	11900	0.01 (0.005—0.016)	115
	1.0	30	9500	0.005 (0.005—0.007)	45	30	9500	0.01 (0.007—0.020)	95
	1.2	40	10600	0.005 (0.006—0.008)	50	30	7900	0.015 (0.008—0.024)	115
	1.6	40	7900	0.01 (0.008—0.011)	75	40	7900	0.02 (0.011—0.032)	155
	2.0	40	6300	0.01 (0.010—0.013)	60	40	6300	0.025 (0.013—0.040)	155
	2.5	50	6300	0.015 (0.013—0.017)	90	40	5000	0.03 (0.017—0.050)	150
	3.0	50	5300	0.015 (0.015—0.020)	75	40	4200	0.04 (0.020—0.060)	165
Серый чугун (≤350МПа) GG30					Ковкий чугун (≤450МПа) GGG45				
	0.8	50	19800	0.01 (0.008—0.016)	195	40	15900	0.005 (0.005—0.008)	75
	1.0	50	15900	0.015 (0.010—0.020)	235	40	12700	0.005 (0.007—0.010)	60
	1.2	60	15900	0.015 (0.012—0.024)	235	50	13200	0.01 (0.008—0.012)	130
	1.6	60	11900	0.02 (0.016—0.032)	235	50	9900	0.01 (0.011—0.016)	95
	2.0	60	9500	0.03 (0.020—0.040)	285	50	7900	0.015 (0.013—0.020)	115
	2.5	70	8900	0.035 (0.025—0.050)	310	60	7600	0.02 (0.017—0.025)	150
	3.0	70	7400	0.045 (0.030—0.060)	330	60	6300	0.025 (0.020—0.030)	155

- 1) Для обеспечения безопасности и надлежащей работы требуется СОЖ высокого давления. (минимальное давление СОЖ = 1000 фунтов/кв. дюйм)
- 2) Фильтр для СОЖ должен быть не более 5 мкм.  
Тонкая фильтрация необходима для того, чтобы предотвратить забивание отверстий в сверле, предназначенных для подвода СОЖ.
- 3) Требуется направляющее отверстие или направляющая втулка.

★ : Со склада в Японии.

## РЕКОМЕНДУЕМЫЕ РЕЖИМЫ РЕЗАНИЯ

Обработываемый материал	Алюминиевые сплавы (Si<5%)				Медь, Медный сплав			
	Не растворимая в воде СОЖ • Растворимая в воде СОЖ				Не растворимая в воде СОЖ • Растворимая в воде СОЖ			
Тип СОЖ	Скорость резания (м/мин)	Частота вращения (мин <sup>-1</sup> )	Подача (мин. — макс.) (мм/об)	Подача (мм/мин)	Скорость резания (м/мин)	Частота вращения (мин <sup>-1</sup> )	Подача (мин. — макс.) (мм/об)	Подача (мм/мин)
0.8	50	19800	0.01 (0.008—0.016)	195	40	15900	0.01 (0.008—0.016)	155
1.0	60	19000	0.015 (0.010—0.020)	285	50	15900	0.015 (0.010—0.020)	235
1.2	70	18500	0.015 (0.012—0.024)	275	60	15900	0.015 (0.012—0.024)	235
1.6	80	15900	0.02 (0.016—0.032)	315	70	13900	0.02 (0.016—0.032)	275
2.0	90	14300	0.03 (0.020—0.040)	425	80	12700	0.03 (0.020—0.040)	380
2.5	100	12700	0.035 (0.025—0.050)	440	90	11400	0.035 (0.025—0.050)	395
3.0	100	10600	0.045 (0.030—0.060)	475	100	10600	0.045 (0.030—0.060)	475

- 1) Для обеспечения безопасности и надлежащей работы требуется СОЖ высокого давления. (минимальное давление СОЖ = 1000 фунтов/кв. дюйм)
- 2) Фильтр для СОЖ должен быть не более 5 мкм.  
Тонкая фильтрация необходима для того, чтобы предотвратить забивание отверстий в сверле, предназначенных для подвода СОЖ.
- 3) Требуется направляющее отверстие или направляющая втулка.

## СПЕЦИАЛЬНЫЕ УКАЗАНИЯ

- Требуется направляющее отверстие или направляющая втулка.
- Фильтр для СОЖ должен быть не более 5 мкм.  
Тонкая фильтрация необходима для того, чтобы предотвратить забивание отверстий в сверле, предназначенных для подвода СОЖ.
- Давление СОЖ должно быть не менее 10 МПа.  
(При слишком низком давлении возможно блокирование каналов стружкой.)

## РУКОВОДСТВО ДЛЯ ПОЛЬЗОВАНИЯ

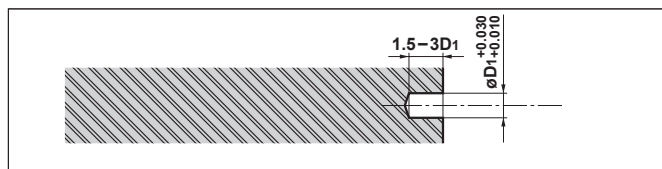

1. Просверлить направляющее отверстие.  
(Рекомендуется серии MWE или MPS.)

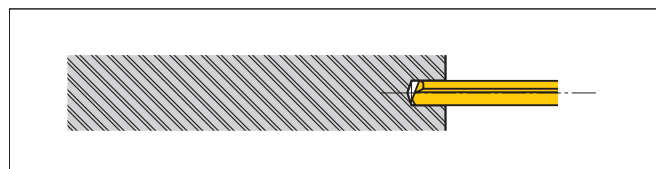

2. Подвести сверло в направляющее отверстие без вращения или с вращением в противоположном направлении при скорости до 300 об/мин. Остановить ружейное сверло MGS, не доходя 1–2 мм до дна направляющего отверстия.

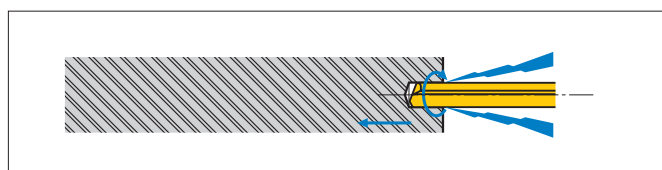

3. Включите подачу СОЖ, повысьте скорость резания и задайте рекомендуемые параметры для подачи. После этого приступите к сверлению.

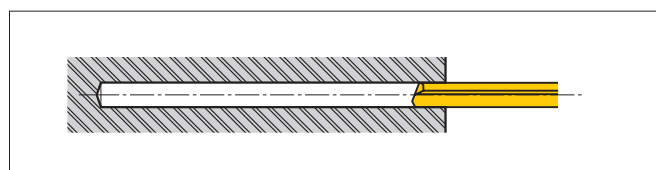

4. После сверления возвратитесь в положение "П. 2", выключите подачу СОЖ и остановите вращение шпинделя.

# СВЕРЛЕНИЕ (МОНОЛИТНЫЕ ТВЕРДОСПЛАВНЫЕ СВЕРЛА)

● Для высокоточного и эффективного сверления нержавеющих сталей.

## MMS

ТВЕРДЫЙ  
СПЛАВ

Углеродистая сталь Легированная сталь	Закалённая сталь	Нержавеющая сталь	Чугун	Лёгкий сплав	Жаропрочные сплавы
--	---------------------	----------------------	-------	--------------	-----------------------



	D1=3	3<D1≤6	6<D1≤10	10<D1≤18	18<D1≤20
DIN Тип (m7)	+0.012 +0.002	+0.016 +0.004	+0.021 +0.006	+0.025 +0.007	+0.029 +0.008
Прочее (h8)	0 -0.014	0 -0.018	0 -0.022	0 -0.027	0 -0.033
h6 ↓		0 -0.008	0 -0.009	0 -0.011	0 -0.013

### ● Тип 1 Цилиндрический хвостовик

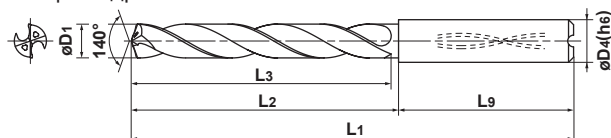

MMS----S/L-DIN-C (l/d 3-5)  
MMS----X3/X5DB (l/d 3-5)

### ● Тип 3 Цилиндрический хвостовик с конической шейкой

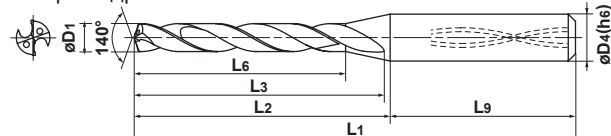

MMS----S/L-DIN-C (l/d 3-5)  
MMS----X3/X5DB (l/d 3-5)

### ● Тип 2 Хвостовик с лыской

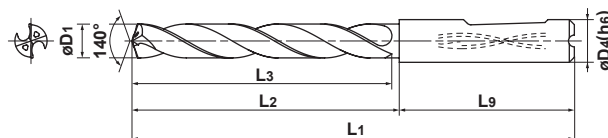

MMS----S/L-DIN (l/d 3-5)

### ● Тип 4 Хвостовик с лыской с конической шейкой

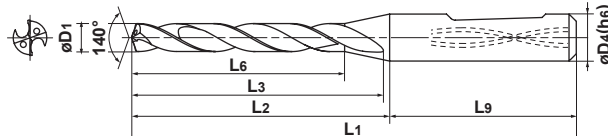

MMS----S/L-DIN (l/d 3-5)

Диам. сверла D1 (мм)	Глубина сверления (l/d)	Наличие DP7020	Обозначение	Размеры (мм)						Тип
				L1	L2	L3	L6	L9	D4	
3.0	3	●	MMS0300S-DIN	62	26	20	19.4	36	6	4
	3	●	0300S-DIN-C	62	26	20	19.4	36	6	3
	5	●	0300L-DIN	66	30	28	23.4	36	6	4
	5	●	0300L-DIN-C	66	30	28	23.4	36	6	3
	3	★	0300X3DB	71	24	22	18.4	47	6	3
	5	★	0300X5DB	79	32	29	26.4	47	6	3
3.05	3	□	0305S-DIN	62	26	20	20.3	36	6	4
	3	●	0305S-DIN-C	62	26	20	20.3	36	6	3
	5	□	0305L-DIN	66	30	28	24.3	36	6	4
	5	●	0305L-DIN-C	66	30	28	24.3	36	6	3
3.1	3	□	0310S-DIN	62	26	20	20.3	36	6	4
	3	●	0310S-DIN-C	62	26	20	20.3	36	6	3
	5	□	0310L-DIN	66	30	28	24.3	36	6	4
	5	●	0310L-DIN-C	66	30	28	24.3	36	6	3
	3	★	0310X3DB	71	24	22	19.3	47	6	3
	5	★	0310X5DB	79	32	29	27.3	47	6	3
3.2	3	□	0320S-DIN	62	26	20	20.3	36	6	4
	3	●	0320S-DIN-C	62	26	20	20.3	36	6	3
	5	□	0320L-DIN	66	30	28	24.3	36	6	4
	5	●	0320L-DIN-C	66	30	28	24.3	36	6	3
	3	★	0320X3DB	71	24	22	19.3	47	6	3
	5	★	0320X5DB	79	32	29	27.3	47	6	3
3.3	3	□	0330S-DIN	62	26	20	20.3	36	6	4
	3	●	0330S-DIN-C	62	26	20	20.3	36	6	3
	5	□	0330L-DIN	66	30	28	24.3	36	6	4
	5	●	0330L-DIN-C	66	30	28	24.3	36	6	3
	3	★	0330X3DB	71	24	22	19.3	47	6	3
	5	★	0330X5DB	79	32	29	27.3	47	6	3
3.4	3	□	0340S-DIN	62	26	20	20.3	36	6	4
	3	●	0340S-DIN-C	62	26	20	20.3	36	6	3
	5	□	0340L-DIN	66	30	28	24.3	36	6	4

Диам. сверла D1 (мм)	Глубина сверления (l/d)	Наличие DP7020	Обозначение	Размеры (мм)						Тип
				L1	L2	L3	L6	L9	D4	
3.4	5	●	MMS0340L-DIN-C	66	30	28	24.3	36	6	3
	3	★	0340X3DB	71	24	22	19.3	47	6	3
	5	★	0340X5DB	79	32	29	27.3	47	6	3
3.5	3	□	0350S-DIN	62	26	20	20.3	36	6	4
	3	●	0350S-DIN-C	62	26	20	20.3	36	6	3
	5	□	0350L-DIN	66	30	28	24.3	36	6	4
	5	●	0350L-DIN-C	66	30	28	24.3	36	6	3
	3	★	0350X3DB	71	24	22	19.3	47	6	3
3.6	5	★	0350X5DB	79	32	29	27.3	47	6	3
	3	□	0360S-DIN	62	26	20	20.8	36	6	4
	3	●	0360S-DIN-C	62	26	20	20.8	36	6	3
	5	□	0360L-DIN	66	30	28	24.8	36	6	4
	5	●	0360L-DIN-C	66	30	28	24.8	36	6	3
3.7	3	★	0360X3DB	71	24	23	20.3	47	6	3
	5	★	0360X5DB	79	32	31	28.3	47	6	3
	3	□	0370S-DIN	62	26	20	20.8	36	6	4
	3	●	0370S-DIN-C	62	26	20	20.8	36	6	3
	5	□	0370L-DIN	66	30	28	24.8	36	6	4
3.8	5	●	0370L-DIN-C	66	30	28	24.8	36	6	3
	3	★	0370X3DB	71	24	23	20.3	47	6	3
	5	★	0370X5DB	79	32	31	28.3	47	6	3
	3	□	0380S-DIN	66	30	24	25.3	36	6	4
	3	●	0380S-DIN-C	66	30	24	25.3	36	6	3
3.9	5	□	0380L-DIN	74	38	36	33.3	36	6	4
	5	●	0380L-DIN-C	74	38	36	33.3	36	6	3
	3	★	0380X3DB	71	24	23	20.3	47	6	3
	5	★	0380X5DB	79	32	31	28.3	47	6	3
	3	□	0390S-DIN	66	30	24	25.3	36	6	4
3.9	3	●	0390S-DIN-C	66	30	24	25.3	36	6	3
	5	□	0390L-DIN	74	38	36	33.3	36	6	4
	5	●	0390L-DIN-C	74	38	36	33.3	36	6	3

● : Есть на складе. ★ : Со склада в Японии.

□ : Нет на складе, выпускается исключительно под заказ.

L058

СВЕРЛЕНИЕ

Диам. сверла D1 (мм)	Глубина сверления (l/d)	Наличие DP7020	Обозначение	Размеры (мм)						Тип
				L1	L2	L3	L6	L9	D4	
3.9	3	★	MMS0390X3DB	71	24	23	20.3	47	6	3
	5	★	0390X5DB	79	32	31	28.3	47	6	3
4.0	3	●	0400S-DIN	66	30	24	25.3	36	6	4
	3	●	0400S-DIN-C	66	30	24	25.3	36	6	3
	5	●	0400L-DIN	74	38	36	33.3	36	6	4
	5	●	0400L-DIN-C	74	38	36	33.3	36	6	3
	3	★	0400X3DB	71	24	23	20.3	47	6	3
	5	★	0400X5DB	79	32	31	28.3	47	6	3
4.05	3	□	0405S-DIN	66	30	24	26.2	36	6	4
	3	●	0405S-DIN-C	66	30	24	26.2	36	6	3
	5	□	0405L-DIN	74	38	36	34.2	36	6	4
	5	●	0405L-DIN-C	74	38	36	34.2	36	6	3
4.1	3	□	0410S-DIN	66	30	24	26.2	36	6	4
	3	●	0410S-DIN-C	66	30	24	26.2	36	6	3
	5	□	0410L-DIN	74	38	36	34.2	36	6	4
	5	●	0410L-DIN-C	74	38	36	34.2	36	6	3
	3	★	0410X3DB	74	27	25	24.2	47	6	3
4.2	3	●	0420S-DIN	66	30	24	26.2	36	6	4
	3	●	0420S-DIN-C	66	30	24	26.2	36	6	3
	5	●	0420L-DIN	74	38	36	34.2	36	6	4
	5	●	0420L-DIN-C	74	38	36	34.2	36	6	3
	3	★	0420X3DB	74	27	25	24.2	47	6	3
4.3	3	□	0430S-DIN	66	30	24	26.2	36	6	4
	3	●	0430S-DIN-C	66	30	24	26.2	36	6	3
	5	□	0430L-DIN	74	38	36	34.2	36	6	4
	5	●	0430L-DIN-C	74	38	36	34.2	36	6	3
	3	★	0430X3DB	74	27	25	24.2	47	6	3
	5	★	0430X5DB	83	36	34	33.2	47	6	3
4.4	3	□	0440S-DIN	66	30	24	26.2	36	6	4
	3	□	0440S-DIN-C	66	30	24	26.2	36	6	3
	5	□	0440L-DIN	74	38	36	34.2	36	6	4
	5	□	0440L-DIN-C	74	38	36	34.2	36	6	3
	3	★	0440X3DB	74	27	25	24.2	47	6	3
	5	★	0440X5DB	83	36	34	33.2	47	6	3
4.5	3	□	0450S-DIN	66	30	24	26.2	36	6	4
	3	●	0450S-DIN-C	66	30	24	26.2	36	6	3
	5	□	0450L-DIN	74	38	36	34.2	36	6	4
	5	●	0450L-DIN-C	74	38	36	34.2	36	6	3
	3	★	0450X3DB	74	27	25	24.2	47	6	3
	5	★	0450X5DB	83	36	34	33.2	47	6	3
4.6	3	□	0460S-DIN	66	30	24	—	36	6	2
	3	●	0460S-DIN-C	66	30	24	—	36	6	1
	5	□	0460L-DIN	74	38	36	—	36	6	2
	5	●	0460L-DIN-C	74	38	36	—	36	6	1
	3	★	0460X3DB	76	29	26	—	47	6	1
	5	★	0460X5DB	86	39	36	—	47	6	1
4.65	3	□	0465S-DIN	66	30	24	—	36	6	2
	3	●	0465S-DIN-C	66	30	24	—	36	6	1

Диам. сверла D1 (мм)	Глубина сверления (l/d)	Наличие DP7020	Обозначение	Размеры (мм)						Тип
				L1	L2	L3	L6	L9	D4	
4.65	5	□	MMS0465L-DIN	74	38	36	—	36	6	2
	5	●	0465L-DIN-C	74	38	36	—	36	6	1
4.7	3	□	0470S-DIN	66	30	24	—	36	6	2
	3	□	0470S-DIN-C	66	30	24	—	36	6	1
	5	□	0470L-DIN	74	38	36	—	36	6	2
	5	□	0470L-DIN-C	74	38	36	—	36	6	1
	3	★	0470X3DB	76	29	26	—	47	6	1
	5	★	0470X5DB	86	39	36	—	47	6	1
4.8	3	□	0480S-DIN	66	30	28	—	36	6	2
	3	●	0480S-DIN-C	66	30	28	—	36	6	1
	5	□	0480L-DIN	82	46	44	—	36	6	2
	5	●	0480L-DIN-C	82	46	44	—	36	6	1
	3	★	0480X3DB	76	29	26	—	47	6	1
4.9	5	★	0480X5DB	86	39	36	—	47	6	1
	3	□	0490S-DIN	66	30	28	—	36	6	2
	3	□	0490S-DIN-C	66	30	28	—	36	6	1
	5	□	0490L-DIN	82	46	44	—	36	6	2
	5	□	0490L-DIN-C	82	46	44	—	36	6	1
5.0	3	★	0490X3DB	76	29	26	—	47	6	1
	5	★	0490X5DB	86	39	36	—	47	6	1
	3	●	0500S-DIN	66	30	28	—	36	6	2
	3	●	0500S-DIN-C	66	30	28	—	36	6	1
	5	●	0500L-DIN	82	46	44	—	36	6	2
5.05	5	●	0500L-DIN-C	82	46	44	—	36	6	1
	3	★	0500X3DB	76	29	26	—	47	6	1
	5	★	0500X5DB	86	39	36	—	47	6	1
	3	□	0505S-DIN	66	30	28	—	36	6	2
	3	●	0505S-DIN-C	66	30	28	—	36	6	1
5.1	5	□	0505L-DIN	82	46	44	—	36	6	2
	5	●	0505L-DIN-C	82	46	44	—	36	6	1
	3	★	0510X3DB	82	31	29	—	51	6	1
	5	★	0510X5DB	90	43	40	—	47	6	1
	3	□	0520S-DIN	66	30	28	—	36	6	2
5.2	3	●	0520S-DIN-C	66	30	28	—	36	6	1
	5	□	0520L-DIN	82	46	44	—	36	6	2
	5	●	0520L-DIN-C	82	46	44	—	36	6	1
	3	★	0520X3DB	82	31	29	—	51	6	1
	5	★	0520X5DB	90	43	40	—	47	6	1
	3	□	0530S-DIN	66	30	28	—	36	6	2
5.3	3	□	0530S-DIN-C	66	30	28	—	36	6	1
	5	□	0530L-DIN	82	46	44	—	36	6	2
	5	□	0530L-DIN-C	82	46	44	—	36	6	1
	3	★	0530X3DB	82	31	29	—	51	6	1
	5	★	0530X5DB	90	43	40	—	47	6	1
	3	□	0540S-DIN	66	30	28	—	36	6	2
5.4	3	□	0540S-DIN-C	66	30	28	—	36	6	1

РЕЖИМЫ РЕЗАНИЯ > L070  
 ИНСТРУКЦИЯ ПО ЭКСПЛУАТАЦИИ > L069  
 ТЕХНИЧЕСКИЕ ДАННЫЕ > N001

# СВЕРЛЕНИЕ (МОНОЛИТНЫЕ ТВЕРДОСПЛАВНЫЕ СВЕРЛА)

# MMS

ТВЕРДЫЙ  
СПЛАВ

Диам. сверла D1 (мм)	Глубина сверления (l/d)	Наличие DP7020	Обозначение	Размеры (мм)						Тип
				L1	L2	L3	L6	L9	D4	
5.4	5	□	MMS0540L-DIN	82	46	44	—	36	6	2
	5	□	0540L-DIN-C	82	46	44	—	36	6	1
	3	★	0540X3DB	82	31	29	—	51	6	1
	5	★	0540X5DB	90	43	40	—	47	6	1
5.5	3	□	0550S-DIN	66	30	28	—	36	6	2
	3	●	0550S-DIN-C	66	30	28	—	36	6	1
	5	□	0550L-DIN	82	46	44	—	36	6	2
	5	●	0550L-DIN-C	82	46	44	—	36	6	1
	3	★	0550X3DB	82	31	29	—	51	6	1
	5	★	0550X5DB	90	43	40	—	47	6	1
5.55	3	□	0555S-DIN	66	30	28	—	36	6	2
	3	●	0555S-DIN-C	66	30	28	—	36	6	1
	5	●	0555L-DIN-C	82	46	44	—	36	6	1
5.6	3	□	0560S-DIN	66	30	28	—	36	6	2
	3	●	0560S-DIN-C	66	30	28	—	36	6	1
	5	□	0560L-DIN	82	46	44	—	36	6	2
	5	●	0560L-DIN-C	82	46	44	—	36	6	1
	3	★	0560X3DB	82	31	31	—	51	6	1
5.7	3	□	0570S-DIN	66	30	28	—	36	6	2
	3	●	0570S-DIN-C	66	30	28	—	36	6	1
	5	□	0570L-DIN	82	46	44	—	36	6	2
	5	●	0570L-DIN-C	82	46	44	—	36	6	1
	3	★	0570X3DB	82	31	31	—	51	6	1
5.8	3	□	0580S-DIN	66	30	28	—	36	6	2
	3	●	0580S-DIN-C	66	30	28	—	36	6	1
	5	□	0580L-DIN	82	46	44	—	36	6	2
	5	●	0580L-DIN-C	82	46	44	—	36	6	1
	3	★	0580X3DB	82	31	31	—	51	6	1
5.9	3	□	0590S-DIN	66	30	28	—	36	6	2
	3	□	0590S-DIN-C	66	30	28	—	36	6	1
	5	□	0590L-DIN	82	46	44	—	36	6	2
	5	□	0590L-DIN-C	82	46	44	—	36	6	1
	3	★	0590X3DB	82	31	31	—	51	6	1
6.0	3	●	0600S-DIN	66	30	28	—	36	6	2
	3	●	0600S-DIN-C	66	30	28	—	36	6	1
	5	●	0600L-DIN	82	46	44	—	36	6	2
	5	●	0600L-DIN-C	82	46	44	—	36	6	1
	3	★	0600X3DB	82	31	31	—	51	6	1
6.05	3	□	0605S-DIN	79	43	34	—	36	8	2
	3	●	0605S-DIN-C	79	43	34	—	36	8	1
	5	□	0605L-DIN	91	55	53	—	36	8	2
	5	●	0605L-DIN-C	91	55	53	—	36	8	1
6.1	3	□	0610S-DIN	79	43	34	—	36	8	2
	3	●	0610S-DIN-C	79	43	34	—	36	8	1
	5	□	0610L-DIN	91	55	53	—	36	8	2
	5	●	0610L-DIN-C	91	55	53	—	36	8	1

Диам. сверла D1 (мм)	Глубина сверления (l/d)	Наличие DP7020	Обозначение	Размеры (мм)						Тип
				L1	L2	L3	L6	L9	D4	
6.1	3	★	MMS0610X3DB	87	36	34	—	51	8	1
	5	★	0610X5DB	96	49	47	—	47	8	1
6.2	3	□	0620S-DIN	79	43	34	—	36	8	2
	3	●	0620S-DIN-C	79	43	34	—	36	8	1
	5	□	0620L-DIN	91	55	53	—	36	8	2
	5	●	0620L-DIN-C	91	55	53	—	36	8	1
	3	★	0620X3DB	87	36	34	—	51	8	1
6.3	5	★	0620X5DB	96	49	47	—	47	8	1
	3	□	0630S-DIN	79	43	34	—	36	8	2
	3	□	0630S-DIN-C	79	43	34	—	36	8	1
	5	□	0630L-DIN	91	55	53	—	36	8	2
	5	□	0630L-DIN-C	91	55	53	—	36	8	1
6.4	3	★	0630X3DB	87	36	34	—	51	8	1
	5	★	0630X5DB	96	49	47	—	47	8	1
	3	□	0640S-DIN	79	43	34	—	36	8	2
	3	□	0640S-DIN-C	79	43	34	—	36	8	1
	5	□	0640L-DIN	91	55	53	—	36	8	2
6.5	5	□	0640L-DIN-C	91	55	53	—	36	8	1
	3	★	0640X3DB	87	36	34	—	51	8	1
	5	★	0640X5DB	96	49	47	—	47	8	1
	3	□	0650S-DIN	79	43	34	—	36	8	2
	3	●	0650S-DIN-C	79	43	34	—	36	8	1
6.6	5	□	0650L-DIN	91	55	53	—	36	8	2
	5	●	0650L-DIN-C	91	55	53	—	36	8	1
	3	★	0650X3DB	87	36	34	—	51	8	1
	5	★	0650X5DB	96	49	47	—	47	8	1
	3	□	0660S-DIN	79	43	34	—	36	8	2
6.7	3	●	0660S-DIN-C	79	43	34	—	36	8	1
	5	□	0660L-DIN	91	55	53	—	36	8	2
	5	●	0660L-DIN-C	91	55	53	—	36	8	1
	3	★	0660X3DB	91	38	36	—	53	8	1
	5	★	0660X5DB	99	52	50	—	47	8	1
6.8	3	□	0670S-DIN	79	43	34	—	36	8	2
	3	□	0670S-DIN-C	79	43	34	—	36	8	1
	5	□	0670L-DIN	91	55	53	—	36	8	2
	5	□	0670L-DIN-C	91	55	53	—	36	8	1
	3	★	0670X3DB	91	38	36	—	53	8	1
6.9	5	★	0670X5DB	99	52	50	—	47	8	1
	3	●	0680S-DIN	79	43	34	—	36	8	2
	3	●	0680S-DIN-C	79	43	34	—	36	8	1
	5	●	0680L-DIN	91	55	53	—	36	8	2
	5	●	0680L-DIN-C	91	55	53	—	36	8	1
6.9	3	★	0680X3DB	91	38	36	—	53	8	1
	5	★	0680X5DB	99	52	50	—	47	8	1
	3	□	0690S-DIN	79	43	34	—	36	8	2
	3	●	0690S-DIN-C	79	43	34	—	36	8	1
	5	□	0690L-DIN	91	55	53	—	36	8	2
6.1	5	●	0690L-DIN-C	91	55	53	—	36	8	1
	3	★	0690X3DB	91	38	36	—	53	8	1
	5	★	0690X5DB	99	52	50	—	47	8	1

● : Есть на складе. ★ : Со склада в Японии.

□ : Нет на складе, выпускается исключительно под заказ.

L060

СВЕРЛЕНИЕ

Диам. сверла D1 (мм)	Глубина сверления (l/d)	Наличие DP7020	Обозначение	Размеры (мм)						Тип
				L1	L2	L3	L6	L9	D4	
7.0	3	●	MMS0700S-DIN	79	43	34	—	36	8	2
	3	●	0700S-DIN-C	79	43	34	—	36	8	1
	5	●	0700L-DIN	91	55	53	—	36	8	2
	5	●	0700L-DIN-C	91	55	53	—	36	8	1
	3	★	0700X3DB	91	38	36	—	53	8	1
	5	★	0700X5DB	99	52	50	—	47	8	1
7.1	3	□	0710S-DIN	79	43	41	—	36	8	2
	3	□	0710S-DIN-C	79	43	41	—	36	8	1
	5	□	0710L-DIN	91	55	53	—	36	8	2
	5	□	0710L-DIN-C	91	55	53	—	36	8	1
	3	★	0710X3DB	91	40	39	—	51	8	1
	5	★	0710X5DB	104	57	54	—	47	8	1
7.2	3	□	0720S-DIN	79	43	41	—	36	8	2
	3	□	0720S-DIN-C	79	43	41	—	36	8	1
	5	□	0720L-DIN	91	55	53	—	36	8	2
	5	□	0720L-DIN-C	91	55	53	—	36	8	1
	3	★	0720X3DB	91	40	39	—	51	8	1
	5	★	0720X5DB	104	57	54	—	47	8	1
7.3	3	□	0730S-DIN	79	43	41	—	36	8	2
	3	●	0730S-DIN-C	79	43	41	—	36	8	1
	5	□	0730L-DIN	91	55	53	—	36	8	2
	5	●	0730L-DIN-C	91	55	53	—	36	8	1
	3	★	0730X3DB	91	40	39	—	51	8	1
	5	★	0730X5DB	104	57	54	—	47	8	1
7.4	3	□	0740S-DIN	79	43	41	—	36	8	2
	3	●	0740S-DIN-C	79	43	41	—	36	8	1
	5	□	0740L-DIN	91	55	53	—	36	8	2
	5	●	0740L-DIN-C	91	55	53	—	36	8	1
	3	★	0740X3DB	91	40	39	—	51	8	1
	5	★	0740X5DB	104	57	54	—	47	8	1
7.5	3	□	0750S-DIN	79	43	41	—	36	8	2
	3	●	0750S-DIN-C	79	43	41	—	36	8	1
	5	□	0750L-DIN	91	55	53	—	36	8	2
	5	●	0750L-DIN-C	91	55	53	—	36	8	1
	3	★	0750X3DB	91	40	39	—	51	8	1
	5	★	0750X5DB	104	57	54	—	47	8	1
7.6	3	□	0760S-DIN	79	43	41	—	36	8	2
	3	□	0760S-DIN-C	79	43	41	—	36	8	1
	5	□	0760L-DIN	91	55	53	—	36	8	2
	5	□	0760L-DIN-C	91	55	53	—	36	8	1
	3	★	0760X3DB	91	41	41	—	50	8	1
	5	★	0760X5DB	104	57	57	—	47	8	1
7.7	3	□	0770S-DIN	79	43	41	—	36	8	2
	3	□	0770S-DIN-C	79	43	41	—	36	8	1
	5	□	0770L-DIN	91	55	53	—	36	8	2
	5	□	0770L-DIN-C	91	55	53	—	36	8	1
	3	★	0770X3DB	91	41	41	—	50	8	1
	5	★	0770X5DB	104	57	57	—	47	8	1

Диам. сверла D1 (мм)	Глубина сверления (l/d)	Наличие DP7020	Обозначение	Размеры (мм)						Тип
				L1	L2	L3	L6	L9	D4	
7.8	3	□	MMS0780S-DIN	79	43	41	—	36	8	2
	3	●	0780S-DIN-C	79	43	41	—	36	8	1
	5	□	0780L-DIN	91	55	53	—	36	8	2
	5	●	0780L-DIN-C	91	55	53	—	36	8	1
	3	★	0780X3DB	91	41	41	—	50	8	1
	5	★	0780X5DB	104	57	57	—	47	8	1
7.9	3	□	0790S-DIN	79	43	41	—	36	8	2
	3	□	0790S-DIN-C	79	43	41	—	36	8	1
	5	□	0790L-DIN	91	55	53	—	36	8	2
	5	□	0790L-DIN-C	91	55	53	—	36	8	1
	3	★	0790X3DB	91	41	41	—	50	8	1
	5	★	0790X5DB	104	57	57	—	47	8	1
8.0	3	●	0800S-DIN	79	43	41	—	36	8	2
	3	●	0800S-DIN-C	79	43	41	—	36	8	1
	5	●	0800L-DIN	91	55	53	—	36	8	2
	5	●	0800L-DIN-C	91	55	53	—	36	8	1
	3	★	0800X3DB	91	41	41	—	50	8	1
	5	★	0800X5DB	104	57	57	—	47	8	1
8.05	3	□	0805S-DIN	88	48	46	—	40	10	2
	3	●	0805S-DIN-C	88	48	46	—	40	10	1
	5	□	0805L-DIN	102	62	60	—	40	10	2
	5	●	0805L-DIN-C	102	62	60	—	40	10	1
	8.1	3	□	0810S-DIN	88	48	46	—	40	10
3		□	0810S-DIN-C	88	48	46	—	40	10	1
5		□	0810L-DIN	102	62	60	—	40	10	2
5		□	0810L-DIN-C	102	62	60	—	40	10	1
3		★	0810X3DB	97	46	44	—	51	10	1
5		★	0810X5DB	114	63	61	—	51	10	1
8.2	3	□	0820S-DIN	88	48	46	—	40	10	2
	3	□	0820S-DIN-C	88	48	46	—	40	10	1
	5	□	0820L-DIN	102	62	60	—	40	10	2
	5	□	0820L-DIN-C	102	62	60	—	40	10	1
	3	★	0820X3DB	97	46	44	—	51	10	1
8.3	3	□	0830S-DIN	88	48	46	—	40	10	2
	3	●	0830S-DIN-C	88	48	46	—	40	10	1
	5	□	0830L-DIN	102	62	60	—	40	10	2
	5	●	0830L-DIN-C	102	62	60	—	40	10	1
	3	★	0830X3DB	97	46	44	—	51	10	1
8.4	3	□	0840S-DIN	88	48	46	—	40	10	2
	3	□	0840S-DIN-C	88	48	46	—	40	10	1
	5	□	0840L-DIN	102	62	60	—	40	10	2
	5	□	0840L-DIN-C	102	62	60	—	40	10	1
	3	★	0840X3DB	97	46	44	—	51	10	1
	5	★	0840X5DB	114	63	61	—	51	10	1

# СВЕРЛЕНИЕ (МОНОЛИТНЫЕ ТВЕРДОСПЛАВНЫЕ СВЕРЛА)

# MMS

ТВЕРДЫЙ  
СПЛАВ

СВЕРЛЕНИЕ

Диам. сверла D1 (мм)	Глубина сверления (l/d)	Наличие DP7020	Обозначение	Размеры (мм)						Тип
				L1	L2	L3	L6	L9	D4	
8.5	3	●	MMS0850S-DIN	88	48	46	—	40	10	2
	3	●	0850S-DIN-C	88	48	46	—	40	10	1
	5	●	0850L-DIN	102	62	60	—	40	10	2
	5	●	0850L-DIN-C	102	62	60	—	40	10	1
	3	★	0850X3DB	97	46	44	—	51	10	1
	5	★	0850X5DB	114	63	61	—	51	10	1
8.6	3	□	0860S-DIN	88	48	46	—	40	10	2
	3	●	0860S-DIN-C	88	48	46	—	40	10	1
	5	□	0860L-DIN	102	62	60	—	40	10	2
	5	●	0860L-DIN-C	102	62	60	—	40	10	1
	3	★	0860X3DB	103	49	47	—	54	10	1
	5	★	0860X5DB	118	67	65	—	51	10	1
8.7	3	□	0870S-DIN	88	48	46	—	40	10	2
	3	●	0870S-DIN-C	88	48	46	—	40	10	1
	5	□	0870L-DIN	102	62	60	—	40	10	2
	5	●	0870L-DIN-C	102	62	60	—	40	10	1
	3	★	0870X3DB	103	49	47	—	54	10	1
	5	★	0870X5DB	118	67	65	—	51	10	1
8.8	3	□	0880S-DIN	88	48	46	—	40	10	2
	3	●	0880S-DIN-C	88	48	46	—	40	10	1
	5	□	0880L-DIN	102	62	60	—	40	10	2
	5	●	0880L-DIN-C	102	62	60	—	40	10	1
	3	★	0880X3DB	103	49	47	—	54	10	1
	5	★	0880X5DB	118	67	65	—	51	10	1
8.9	3	□	0890S-DIN	88	48	46	—	40	10	2
	3	□	0890S-DIN-C	88	48	46	—	40	10	1
	5	□	0890L-DIN	102	62	60	—	40	10	2
	5	□	0890L-DIN-C	102	62	60	—	40	10	1
	3	★	0890X3DB	103	49	47	—	54	10	1
	5	★	0890X5DB	118	67	65	—	51	10	1
9.0	3	□	0900S-DIN	88	48	46	—	40	10	2
	3	●	0900S-DIN-C	88	48	46	—	40	10	1
	5	□	0900L-DIN	102	62	60	—	40	10	2
	5	●	0900L-DIN-C	102	62	60	—	40	10	1
	3	★	0900X3DB	103	49	47	—	54	10	1
	5	★	0900X5DB	118	67	65	—	51	10	1
9.1	3	□	0910S-DIN	89	49	47	—	40	10	2
	3	□	0910S-DIN-C	89	49	47	—	40	10	1
	5	□	0910L-DIN	103	63	62	—	40	10	2
	5	□	0910L-DIN-C	103	63	62	—	40	10	1
	3	★	0910X3DB	103	52	50	—	51	10	1
	5	★	0910X5DB	123	72	69	—	51	10	1
9.2	3	□	0920S-DIN	89	49	47	—	40	10	2
	3	□	0920S-DIN-C	89	49	47	—	40	10	1
	5	□	0920L-DIN	103	63	62	—	40	10	2
	5	□	0920L-DIN-C	103	63	62	—	40	10	1
	3	★	0920X3DB	103	52	50	—	51	10	1
	5	★	0920X5DB	123	72	69	—	51	10	1

Диам. сверла D1 (мм)	Глубина сверления (l/d)	Наличие DP7020	Обозначение	Размеры (мм)						Тип
				L1	L2	L3	L6	L9	D4	
9.3	3	□	MMS0930S-DIN	89	49	47	—	40	10	2
	3	●	0930S-DIN-C	89	49	47	—	40	10	1
	5	□	0930L-DIN	103	63	62	—	40	10	2
	5	●	0930L-DIN-C	103	63	62	—	40	10	1
	3	★	0930X3DB	103	52	50	—	51	10	1
	5	★	0930X5DB	123	72	69	—	51	10	1
9.4	3	□	0940S-DIN	89	49	47	—	40	10	2
	3	□	0940S-DIN-C	89	49	47	—	40	10	1
	5	□	0940L-DIN	103	63	62	—	40	10	2
	5	□	0940L-DIN-C	103	63	62	—	40	10	1
	3	★	0940X3DB	103	52	50	—	51	10	1
	5	★	0940X5DB	123	72	69	—	51	10	1
9.5	3	□	0950S-DIN	89	49	47	—	40	10	2
	3	●	0950S-DIN-C	89	49	47	—	40	10	1
	5	□	0950L-DIN	103	63	62	—	40	10	2
	5	●	0950L-DIN-C	103	63	62	—	40	10	1
	3	★	0950X3DB	103	52	50	—	51	10	1
	5	★	0950X5DB	123	72	69	—	51	10	1
9.6	3	□	0960S-DIN	89	49	47	—	40	10	2
	3	□	0960S-DIN-C	89	49	47	—	40	10	1
	5	□	0960L-DIN	103	63	62	—	40	10	2
	5	□	0960L-DIN-C	103	63	62	—	40	10	1
	3	★	0960X3DB	103	52	52	—	51	10	1
	5	★	0960X5DB	123	72	72	—	51	10	1
9.7	3	□	0970S-DIN	89	49	47	—	40	10	2
	3	□	0970S-DIN-C	89	49	47	—	40	10	1
	5	□	0970L-DIN	103	63	62	—	40	10	2
	5	□	0970L-DIN-C	103	63	62	—	40	10	1
	3	★	0970X3DB	103	52	52	—	51	10	1
	5	★	0970X5DB	123	72	72	—	51	10	1
9.8	3	□	0980S-DIN	89	49	47	—	40	10	2
	3	●	0980S-DIN-C	89	49	47	—	40	10	1
	5	□	0980L-DIN	103	63	62	—	40	10	2
	5	●	0980L-DIN-C	103	63	62	—	40	10	1
	3	★	0980X3DB	103	52	52	—	51	10	1
	5	★	0980X5DB	123	72	72	—	51	10	1
9.9	3	□	0990S-DIN	89	49	47	—	40	10	2
	3	□	0990S-DIN-C	89	49	47	—	40	10	1
	5	□	0990L-DIN	103	63	62	—	40	10	2
	5	□	0990L-DIN-C	103	63	62	—	40	10	1
	3	★	0990X3DB	103	52	52	—	51	10	1
	5	★	0990X5DB	123	72	72	—	51	10	1
10.0	3	●	1000S-DIN	89	49	47	—	40	10	2
	3	●	1000S-DIN-C	89	49	47	—	40	10	1
	5	●	1000L-DIN	103	63	62	—	40	10	2
	5	●	1000L-DIN-C	103	63	62	—	40	10	1
	3	★	1000X3DB	103	52	52	—	51	10	1
	5	★	1000X5DB	123	72	72	—	51	10	1

● : Есть на складе. ★ : Со склада в Японии.

□ : Нет на складе, выпускается исключительно под заказ.

L062

Диам. сверла D1 (мм)	Глубина сверления (l/d)	Наличие DP7020	Обозначение	Размеры (мм)						Тип
				L1	L2	L3	L6	L9	D4	
10.05	3	□	MMS1005S-DIN	102	57	55	—	45	12	2
	3	●	1005S-DIN-C	102	57	55	—	45	12	1
	5	□	1005L-DIN	118	73	71	—	45	12	2
	5	●	1005L-DIN-C	118	73	71	—	45	12	1
10.1	3	□	1010S-DIN	102	57	55	—	45	12	2
	3	□	1010S-DIN-C	102	57	55	—	45	12	1
	5	□	1010L-DIN	118	73	71	—	45	12	2
	5	□	1010L-DIN-C	118	73	71	—	45	12	1
	3	★	1010X3DB	113	57	55	—	56	12	1
	5	★	1010X5DB	136	80	76	—	56	12	1
10.2	3	□	1020S-DIN	102	57	55	—	45	12	2
	3	●	1020S-DIN-C	102	57	55	—	45	12	1
	5	□	1020L-DIN	118	73	71	—	45	12	2
	5	●	1020L-DIN-C	118	73	71	—	45	12	1
	3	★	1020X3DB	113	57	55	—	56	12	1
	5	★	1020X5DB	136	80	76	—	56	12	1
10.3	3	□	1030S-DIN	102	57	55	—	45	12	2
	3	●	1030S-DIN-C	102	57	55	—	45	12	1
	5	□	1030L-DIN	118	73	71	—	45	12	2
	5	●	1030L-DIN-C	118	73	71	—	45	12	1
	3	★	1030X3DB	113	57	55	—	56	12	1
	5	★	1030X5DB	136	80	76	—	56	12	1
10.4	3	□	1040S-DIN	102	57	55	—	45	12	2
	3	●	1040S-DIN-C	102	57	55	—	45	12	1
	5	□	1040L-DIN	118	73	71	—	45	12	2
	5	●	1040L-DIN-C	118	73	71	—	45	12	1
	3	★	1040X3DB	113	57	55	—	56	12	1
	5	★	1040X5DB	136	80	76	—	56	12	1
10.5	3	□	1050S-DIN	102	57	55	—	45	12	2
	3	●	1050S-DIN-C	102	57	55	—	45	12	1
	5	□	1050L-DIN	118	73	71	—	45	12	2
	5	●	1050L-DIN-C	118	73	71	—	45	12	1
	3	★	1050X3DB	113	57	55	—	56	12	1
	5	★	1050X5DB	136	80	76	—	56	12	1
10.6	3	□	1060S-DIN	102	57	55	—	45	12	2
	3	□	1060S-DIN-C	102	57	55	—	45	12	1
	5	□	1060L-DIN	118	73	71	—	45	12	2
	5	□	1060L-DIN-C	118	73	71	—	45	12	1
	3	★	1060X3DB	118	58	57	—	60	12	1
	5	★	1060X5DB	136	80	79	—	56	12	1
10.7	3	□	1070S-DIN	102	57	55	—	45	12	2
	3	●	1070S-DIN-C	102	57	55	—	45	12	1
	5	□	1070L-DIN	118	73	71	—	45	12	2
	5	●	1070L-DIN-C	118	73	71	—	45	12	1
	3	★	1070X3DB	118	58	57	—	60	12	1
	5	★	1070X5DB	136	80	79	—	56	12	1

Диам. сверла D1 (мм)	Глубина сверления (l/d)	Наличие DP7020	Обозначение	Размеры (мм)						Тип
				L1	L2	L3	L6	L9	D4	
10.8	3	□	MMS1080S-DIN	102	57	55	—	45	12	2
	3	●	1080S-DIN-C	102	57	55	—	45	12	1
	5	□	1080L-DIN	118	73	71	—	45	12	2
	5	●	1080L-DIN-C	118	73	71	—	45	12	1
	3	★	1080X3DB	118	58	57	—	60	12	1
10.9	5	★	1080X5DB	136	80	79	—	56	12	1
	3	□	1090S-DIN	102	57	55	—	45	12	2
	3	□	1090S-DIN-C	102	57	55	—	45	12	1
	5	□	1090L-DIN	118	73	71	—	45	12	2
	5	□	1090L-DIN-C	118	73	71	—	45	12	1
11.0	3	★	1090X3DB	118	58	57	—	60	12	1
	5	★	1090X5DB	136	80	79	—	56	12	1
	3	□	1100S-DIN	102	57	55	—	45	12	2
	3	●	1100S-DIN-C	102	57	55	—	45	12	1
	5	□	1100L-DIN	118	73	71	—	45	12	2
11.1	5	●	1100L-DIN-C	118	73	71	—	45	12	1
	3	★	1100X3DB	118	58	57	—	60	12	1
	5	★	1100X5DB	136	80	79	—	56	12	1
	3	□	1110S-DIN	102	57	55	—	45	12	2
	3	□	1110S-DIN-C	102	57	55	—	45	12	1
11.2	5	□	1110L-DIN	118	73	71	—	45	12	2
	5	□	1110L-DIN-C	118	73	71	—	45	12	1
	3	★	1110X3DB	118	62	60	—	56	12	1
	5	★	1110X5DB	142	86	83	—	56	12	1
	3	□	1120S-DIN	102	57	55	—	45	12	2
11.3	3	●	1120S-DIN-C	102	57	55	—	45	12	1
	5	□	1120L-DIN	118	73	71	—	45	12	2
	5	●	1120L-DIN-C	118	73	71	—	45	12	1
	3	★	1120X3DB	118	62	60	—	56	12	1
	5	★	1120X5DB	142	86	83	—	56	12	1
11.4	3	□	1130S-DIN	102	57	55	—	45	12	2
	3	□	1130S-DIN-C	102	57	55	—	45	12	1
	5	□	1130L-DIN	118	73	71	—	45	12	2
	5	□	1130L-DIN-C	118	73	71	—	45	12	1
	3	★	1130X3DB	118	62	60	—	56	12	1
11.5	5	★	1130X5DB	142	86	83	—	56	12	1
	3	□	1140S-DIN	102	57	55	—	45	12	2
	3	●	1140S-DIN-C	102	57	55	—	45	12	1
	5	□	1140L-DIN	118	73	71	—	45	12	2
	5	●	1140L-DIN-C	118	73	71	—	45	12	1
11.5	3	★	1140X3DB	118	62	60	—	56	12	1
	5	★	1140X5DB	142	86	83	—	56	12	1
	3	□	1150S-DIN	102	57	55	—	45	12	2
	3	●	1150S-DIN-C	102	57	55	—	45	12	1
	5	□	1150L-DIN	118	73	71	—	45	12	2
11.5	5	●	1150L-DIN-C	118	73	71	—	45	12	1
	3	★	1150X3DB	118	62	60	—	56	12	1
	5	★	1150X5DB	142	86	83	—	56	12	1

# СВЕРЛЕНИЕ (МОНОЛИТНЫЕ ТВЕРДОСПЛАВНЫЕ СВЕРЛА)

# MMS

ТВЕРДЫЙ  
СПЛАВ

СВЕРЛЕНИЕ

Диам. сверла D1 (мм)	Глубина сверления (l/d)	Наличие DP7020	Обозначение	Размеры (мм)						Тип
				L1	L2	L3	L6	L9	D4	
11.6	3	□	MMS1160S-DIN	102	57	55	—	45	12	2
	3	□	1160S-DIN-C	102	57	55	—	45	12	1
	5	□	1160L-DIN	118	73	71	—	45	12	2
	5	□	1160L-DIN-C	118	73	71	—	45	12	1
	3	★	1160X3DB	118	62	62	—	56	12	1
	5	★	1160X5DB	142	86	86	—	56	12	1
11.7	3	□	1170S-DIN	102	57	55	—	45	12	2
	3	●	1170S-DIN-C	102	57	55	—	45	12	1
	5	□	1170L-DIN	118	73	71	—	45	12	2
	5	●	1170L-DIN-C	118	73	71	—	45	12	1
	3	★	1170X3DB	118	62	62	—	56	12	1
	5	★	1170X5DB	142	86	86	—	56	12	1
11.8	3	□	1180S-DIN	102	57	55	—	45	12	2
	3	●	1180S-DIN-C	102	57	55	—	45	12	1
	5	□	1180L-DIN	118	73	71	—	45	12	2
	5	●	1180L-DIN-C	118	73	71	—	45	12	1
	3	★	1180X3DB	118	62	62	—	56	12	1
	5	★	1180X5DB	142	86	86	—	56	12	1
11.9	3	□	1190S-DIN	102	57	55	—	45	12	2
	3	□	1190S-DIN-C	102	57	55	—	45	12	1
	5	□	1190L-DIN	118	73	71	—	45	12	2
	5	□	1190L-DIN-C	118	73	71	—	45	12	1
	3	★	1190X3DB	118	62	62	—	56	12	1
	5	★	1190X5DB	142	86	86	—	56	12	1
12.0	3	●	1200S-DIN	102	57	55	—	45	12	2
	3	●	1200S-DIN-C	102	57	55	—	45	12	1
	5	●	1200L-DIN	118	73	71	—	45	12	2
	5	●	1200L-DIN-C	118	73	71	—	45	12	1
	3	★	1200X3DB	118	62	62	—	56	12	1
	5	★	1200X5DB	142	86	86	—	56	12	1
12.05	3	□	1205S-DIN	107	62	60	—	45	14	2
	3	●	1205S-DIN-C	107	62	60	—	45	14	1
	5	□	1205L-DIN	124	79	77	—	45	14	2
	5	●	1205L-DIN-C	124	79	77	—	45	14	1
12.1	3	□	1210S-DIN	107	62	60	—	45	14	2
	3	□	1210S-DIN-C	107	62	60	—	45	14	1
	5	□	1210L-DIN	124	79	77	—	45	14	2
	5	□	1210L-DIN-C	124	79	77	—	45	14	1
	3	★	1210X3DB	124	68	65	—	56	14	1
	5	★	1210X5DB	150	94	90	—	56	14	1
12.2	3	□	1220S-DIN	107	62	60	—	45	14	2
	3	□	1220S-DIN-C	107	62	60	—	45	14	1
	5	□	1220L-DIN	124	79	77	—	45	14	2
	5	□	1220L-DIN-C	124	79	77	—	45	14	1
	3	★	1220X3DB	124	68	65	—	56	14	1
	5	★	1220X5DB	150	94	90	—	56	14	1

Диам. сверла D1 (мм)	Глубина сверления (l/d)	Наличие DP7020	Обозначение	Размеры (мм)						Тип
				L1	L2	L3	L6	L9	D4	
12.3	3	□	MMS1230S-DIN	107	62	60	—	45	14	2
	3	□	1230S-DIN-C	107	62	60	—	45	14	1
	5	□	1230L-DIN	124	79	77	—	45	14	2
	5	□	1230L-DIN-C	124	79	77	—	45	14	1
	3	★	1230X3DB	124	68	65	—	56	14	1
	5	★	1230X5DB	150	94	90	—	56	14	1
12.4	3	□	1240S-DIN	107	62	60	—	45	14	2
	3	□	1240S-DIN-C	107	62	60	—	45	14	1
	5	□	1240L-DIN	124	79	77	—	45	14	2
	5	□	1240L-DIN-C	124	79	77	—	45	14	1
	3	★	1240X3DB	124	68	65	—	56	14	1
	5	★	1240X5DB	150	94	90	—	56	14	1
12.5	3	□	1250S-DIN	107	62	60	—	45	14	2
	3	●	1250S-DIN-C	107	62	60	—	45	14	1
	5	□	1250L-DIN	124	79	77	—	45	14	2
	5	●	1250L-DIN-C	124	79	77	—	45	14	1
	3	★	1250X3DB	124	68	65	—	56	14	1
	5	★	1250X5DB	150	94	90	—	56	14	1
12.6	3	□	1260S-DIN	107	62	60	—	45	14	2
	3	●	1260S-DIN-C	107	62	60	—	45	14	1
	5	□	1260L-DIN	124	79	77	—	45	14	2
	5	●	1260L-DIN-C	124	79	77	—	45	14	1
	3	★	1260X3DB	124	68	67	—	56	14	1
	5	★	1260X5DB	150	94	93	—	56	14	1
12.7	3	□	1270S-DIN	107	62	60	—	45	14	2
	3	●	1270S-DIN-C	107	62	60	—	45	14	1
	5	□	1270L-DIN	124	79	77	—	45	14	2
	5	●	1270L-DIN-C	124	79	77	—	45	14	1
	3	★	1270X3DB	124	68	67	—	56	14	1
	5	★	1270X5DB	150	94	93	—	56	14	1
12.8	3	□	1280S-DIN	107	62	60	—	45	14	2
	3	□	1280S-DIN-C	107	62	60	—	45	14	1
	5	□	1280L-DIN	124	79	77	—	45	14	2
	5	□	1280L-DIN-C	124	79	77	—	45	14	1
	3	★	1280X3DB	124	68	67	—	56	14	1
	5	★	1280X5DB	150	94	93	—	56	14	1
12.9	3	□	1290S-DIN	107	62	60	—	45	14	2
	3	□	1290S-DIN-C	107	62	60	—	45	14	1
	5	□	1290L-DIN	124	79	77	—	45	14	2
	5	□	1290L-DIN-C	124	79	77	—	45	14	1
	3	★	1290X3DB	124	68	67	—	56	14	1
	5	★	1290X5DB	150	94	93	—	56	14	1
13.0	3	□	1300S-DIN	107	62	60	—	45	14	2
	3	●	1300S-DIN-C	107	62	60	—	45	14	1
	5	□	1300L-DIN	124	79	77	—	45	14	2
	5	●	1300L-DIN-C	124	79	77	—	45	14	1
	3	★	1300X3DB	124	68	67	—	56	14	1
	5	★	1300X5DB	150	94	93	—	56	14	1

● : Есть на складе. ★ : Со склада в Японии.

□ : Нет на складе, выпускается исключительно под заказ.

L064

Диам. сверла D1 (мм)	Глубина сверления (l/d)	Наличие DP7020	Обозначение	Размеры (мм)						Тип
				L1	L2	L3	L6	L9	D4	
13.1	3	□	MMS1310S-DIN	107	62	60	—	45	14	2
	3	□	1310S-DIN-C	107	62	60	—	45	14	1
	5	□	1310L-DIN	124	79	77	—	45	14	2
	5	□	1310L-DIN-C	124	79	77	—	45	14	1
	3	★	1310X3DB	128	72	70	—	56	14	1
	5	★	1310X5DB	156	100	97	—	56	14	1
13.2	3	□	1320S-DIN	107	62	60	—	45	14	2
	3	□	1320S-DIN-C	107	62	60	—	45	14	1
	5	□	1320L-DIN	124	79	77	—	45	14	2
	5	□	1320L-DIN-C	124	79	77	—	45	14	1
	3	★	1320X3DB	128	72	70	—	56	14	1
	5	★	1320X5DB	156	100	97	—	56	14	1
13.3	3	□	1330S-DIN	107	62	60	—	45	14	2
	3	□	1330S-DIN-C	107	62	60	—	45	14	1
	5	□	1330L-DIN	124	79	77	—	45	14	2
	5	□	1330L-DIN-C	124	79	77	—	45	14	1
	3	★	1330X3DB	128	72	70	—	56	14	1
	5	★	1330X5DB	156	100	97	—	56	14	1
13.4	3	□	1340S-DIN	107	62	60	—	45	14	2
	3	□	1340S-DIN-C	107	62	60	—	45	14	1
	5	□	1340L-DIN	124	79	77	—	45	14	2
	5	□	1340L-DIN-C	124	79	77	—	45	14	1
	3	★	1340X3DB	128	72	70	—	56	14	1
	5	★	1340X5DB	156	100	97	—	56	14	1
13.5	3	□	1350S-DIN	107	62	60	—	45	14	2
	3	●	1350S-DIN-C	107	62	60	—	45	14	1
	5	□	1350L-DIN	124	79	77	—	45	14	2
	5	●	1350L-DIN-C	124	79	77	—	45	14	1
	3	★	1350X3DB	128	72	70	—	56	14	1
	5	★	1350X5DB	156	100	97	—	56	14	1
13.6	3	□	1360S-DIN	107	62	60	—	45	14	2
	3	□	1360S-DIN-C	107	62	60	—	45	14	1
	5	□	1360L-DIN	124	79	77	—	45	14	2
	5	□	1360L-DIN-C	124	79	77	—	45	14	1
	3	★	1360X3DB	128	72	72	—	56	14	1
	5	★	1360X5DB	156	100	100	—	56	14	1
13.7	3	□	1370S-DIN	107	62	60	—	45	14	2
	3	●	1370S-DIN-C	107	62	60	—	45	14	1
	5	□	1370L-DIN	124	79	77	—	45	14	2
	5	●	1370L-DIN-C	124	79	77	—	45	14	1
	3	★	1370X3DB	128	72	72	—	56	14	1
	5	★	1370X5DB	156	100	100	—	56	14	1
13.8	3	□	1380S-DIN	107	62	60	—	45	14	2
	3	□	1380S-DIN-C	107	62	60	—	45	14	1
	5	□	1380L-DIN	124	79	77	—	45	14	2
	5	□	1380L-DIN-C	124	79	77	—	45	14	1
	3	★	1380X3DB	128	72	72	—	56	14	1
	5	★	1380X5DB	156	100	100	—	56	14	1

Диам. сверла D1 (мм)	Глубина сверления (l/d)	Наличие DP7020	Обозначение	Размеры (мм)						Тип
				L1	L2	L3	L6	L9	D4	
13.9	3	□	MMS1390S-DIN	107	62	60	—	45	14	2
	3	□	1390S-DIN-C	107	62	60	—	45	14	1
	5	□	1390L-DIN	124	79	77	—	45	14	2
	5	□	1390L-DIN-C	124	79	77	—	45	14	1
	3	★	1390X3DB	128	72	72	—	56	14	1
	5	★	1390X5DB	156	100	100	—	56	14	1
14.0	3	●	1400S-DIN	107	62	60	—	45	14	2
	3	●	1400S-DIN-C	107	62	60	—	45	14	1
	5	●	1400L-DIN	124	79	77	—	45	14	2
	5	●	1400L-DIN-C	124	79	77	—	45	14	1
	3	★	1400X3DB	128	72	72	—	56	14	1
	5	★	1400X5DB	156	100	100	—	56	14	1
14.05	3	●	1405S-DIN	114	66	64	—	48	16	2
	3	□	1405S-DIN-C	114	66	64	—	48	16	1
	5	●	1405L-DIN	132	84	82	—	48	16	2
	5	□	1405L-DIN-C	132	84	82	—	48	16	1
14.1	3	□	1410S-DIN	114	66	64	—	48	16	2
	3	□	1410S-DIN-C	114	66	64	—	48	16	1
	5	□	1410L-DIN	132	84	82	—	48	16	2
	5	□	1410L-DIN-C	132	84	82	—	48	16	1
	3	★	1410X3DB	138	79	76	—	59	16	1
14.2	3	□	1420S-DIN	114	66	64	—	48	16	2
	3	□	1420S-DIN-C	114	66	64	—	48	16	1
	5	□	1420L-DIN	132	84	82	—	48	16	2
	5	□	1420L-DIN-C	132	84	82	—	48	16	1
	3	★	1420X3DB	138	79	76	—	59	16	1
	5	★	1420X5DB	168	109	105	—	59	16	1
14.3	3	□	1430S-DIN	114	66	64	—	48	16	2
	3	□	1430S-DIN-C	114	66	64	—	48	16	1
	5	□	1430L-DIN	132	84	82	—	48	16	2
	3	★	1430X3DB	138	79	76	—	59	16	1
	5	★	1430X5DB	168	109	105	—	59	16	1
14.4	3	□	1440S-DIN	114	66	64	—	48	16	2
	3	□	1440S-DIN-C	114	66	64	—	48	16	1
	5	□	1440L-DIN	132	84	82	—	48	16	2
	5	□	1440L-DIN-C	132	84	82	—	48	16	1
	3	★	1440X3DB	138	79	76	—	59	16	1
14.5	3	●	1450S-DIN	114	66	64	—	48	16	2
	3	□	1450S-DIN-C	114	66	64	—	48	16	1
	5	●	1450L-DIN	132	84	82	—	48	16	2
	5	□	1450L-DIN-C	132	84	82	—	48	16	1
	3	★	1450X3DB	138	79	76	—	59	16	1
	5	★	1450X5DB	168	109	105	—	59	16	1

# СВЕРЛЕНИЕ (МОНОЛИТНЫЕ ТВЕРДОСПЛАВНЫЕ СВЕРЛА)

# MMS

ТВЕРДЫЙ  
СПЛАВ

СВЕРЛЕНИЕ

Диам. сверла D1 (мм)	Глубина сверления (l/d)	Наличие DP7020	Обозначение	Размеры (мм)						Тип
				L1	L2	L3	L6	L9	D4	
14.6	3	□	MMS1460S-DIN	114	66	64	—	48	16	2
	3	□	1460S-DIN-C	114	66	64	—	48	16	1
	5	□	1460L-DIN	132	84	82	—	48	16	2
	5	□	1460L-DIN-C	132	84	82	—	48	16	1
	3	★	1460X3DB	138	79	78	—	59	16	1
	5	★	1460X5DB	168	109	108	—	59	16	1
14.7	3	□	1470S-DIN	114	66	64	—	48	16	2
	3	□	1470S-DIN-C	114	66	64	—	48	16	1
	5	□	1470L-DIN	132	84	82	—	48	16	2
	5	□	1470L-DIN-C	132	84	82	—	48	16	1
	3	★	1470X3DB	138	79	78	—	59	16	1
	5	★	1470X5DB	168	109	108	—	59	16	1
14.8	3	□	1480S-DIN	114	66	64	—	48	16	2
	3	□	1480S-DIN-C	114	66	64	—	48	16	1
	5	□	1480L-DIN	132	84	82	—	48	16	2
	5	□	1480L-DIN-C	132	84	82	—	48	16	1
	3	★	1480X3DB	138	79	78	—	59	16	1
	5	★	1480X5DB	168	109	108	—	59	16	1
14.9	3	□	1490S-DIN	114	66	64	—	48	16	2
	3	□	1490S-DIN-C	114	66	64	—	48	16	1
	5	□	1490L-DIN	132	84	82	—	48	16	2
	5	□	1490L-DIN-C	132	84	82	—	48	16	1
	3	★	1490X3DB	138	79	78	—	59	16	1
	5	★	1490X5DB	168	109	108	—	59	16	1
15.0	3	●	1500S-DIN	114	66	64	—	48	16	2
	3	□	1500S-DIN-C	114	66	64	—	48	16	1
	5	●	1500L-DIN	132	84	82	—	48	16	2
	5	□	1500L-DIN-C	132	84	82	—	48	16	1
	3	★	1500X3DB	138	79	78	—	59	16	1
	5	★	1500X5DB	168	109	108	—	59	16	1
15.1	3	□	1510S-DIN	115	67	65	—	48	16	2
	3	□	1510S-DIN-C	115	67	65	—	48	16	1
	5	□	1510L-DIN	133	85	83	—	48	16	2
	5	□	1510L-DIN-C	133	85	83	—	48	16	1
	3	★	1510X3DB	142	83	81	—	59	16	1
	5	★	1510X5DB	174	115	112	—	59	16	1
15.2	3	□	1520S-DIN	115	67	65	—	48	16	2
	3	□	1520S-DIN-C	115	67	65	—	48	16	1
	5	□	1520L-DIN	133	85	83	—	48	16	2
	5	□	1520L-DIN-C	133	85	83	—	48	16	1
	3	★	1520X3DB	142	83	81	—	59	16	1
	5	★	1520X5DB	174	115	112	—	59	16	1
15.3	3	□	1530S-DIN	115	67	65	—	48	16	2
	3	□	1530S-DIN-C	115	67	65	—	48	16	1
	5	□	1530L-DIN	133	85	83	—	48	16	2
	5	□	1530L-DIN-C	133	85	83	—	48	16	1
	3	★	1530X3DB	142	83	81	—	59	16	1
	5	★	1530X5DB	174	115	112	—	59	16	1

Диам. сверла D1 (мм)	Глубина сверления (l/d)	Наличие DP7020	Обозначение	Размеры (мм)						Тип
				L1	L2	L3	L6	L9	D4	
15.4	3	□	MMS1540S-DIN	115	67	65	—	48	16	2
	3	□	1540S-DIN-C	115	67	65	—	48	16	1
	5	□	1540L-DIN	133	85	83	—	48	16	2
	5	□	1540L-DIN-C	133	85	83	—	48	16	1
	3	★	1540X3DB	142	83	81	—	59	16	1
	5	★	1540X5DB	174	115	112	—	59	16	1
15.5	3	●	1550S-DIN	115	67	65	—	48	16	2
	3	□	1550S-DIN-C	115	67	65	—	48	16	1
	5	●	1550L-DIN	133	85	83	—	48	16	2
	5	□	1550L-DIN-C	133	85	83	—	48	16	1
	3	★	1550X3DB	142	83	81	—	59	16	1
	5	★	1550X5DB	174	115	112	—	59	16	1
15.6	3	□	1560S-DIN	115	67	65	—	48	16	2
	3	□	1560S-DIN-C	115	67	65	—	48	16	1
	5	□	1560L-DIN	133	85	83	—	48	16	2
	5	□	1560L-DIN-C	133	85	83	—	48	16	1
	3	★	1560X3DB	142	83	83	—	59	16	1
	5	★	1560X5DB	174	115	115	—	59	16	1
15.7	3	□	1570S-DIN	115	67	65	—	48	16	2
	3	□	1570S-DIN-C	115	67	65	—	48	16	1
	5	□	1570L-DIN	133	85	83	—	48	16	2
	5	□	1570L-DIN-C	133	85	83	—	48	16	1
	3	★	1570X3DB	142	83	83	—	59	16	1
	5	★	1570X5DB	174	115	115	—	59	16	1
15.8	3	□	1580S-DIN	115	67	65	—	48	16	2
	3	□	1580S-DIN-C	115	67	65	—	48	16	1
	5	□	1580L-DIN	133	85	83	—	48	16	2
	5	□	1580L-DIN-C	133	85	83	—	48	16	1
	3	★	1580X3DB	142	83	83	—	59	16	1
	5	★	1580X5DB	174	115	115	—	59	16	1
15.9	3	□	1590S-DIN	115	67	65	—	48	16	2
	3	□	1590S-DIN-C	115	67	65	—	48	16	1
	5	□	1590L-DIN	133	85	83	—	48	16	2
	5	□	1590L-DIN-C	133	85	83	—	48	16	1
	3	★	1590X3DB	142	83	83	—	59	16	1
	5	★	1590X5DB	174	115	115	—	59	16	1
16.0	3	●	1600S-DIN	115	67	65	—	48	16	2
	3	□	1600S-DIN-C	115	67	65	—	48	16	1
	5	●	1600L-DIN	133	85	83	—	48	16	2
	5	□	1600L-DIN-C	133	85	83	—	48	16	1
	3	★	1600X3DB	142	83	83	—	59	16	1
	5	★	1600X5DB	174	115	115	—	59	16	1
16.1	3	□	1610S-DIN	123	75	73	—	48	18	2
	3	□	1610S-DIN-C	123	75	73	—	48	18	1
	5	□	1610L-DIN	143	95	93	—	48	18	2
	5	□	1610L-DIN-C	143	95	93	—	48	18	1
	3	□	1610X3DB	148	89	86	—	59	18	1
	5	□	1610X5DB	182	123	119	—	59	18	1

● : Есть на складе. ★ : Со склада в Японии.

□ : Нет на складе, выпускается исключительно под заказ.

L066

Диам. сверла D1 (мм)	Глубина сверления (l/d)	Наличие DP7020	Обозначение	Размеры (мм)						Тип
				L1	L2	L3	L6	L9	D4	
16.2	3	□	MMS1620S-DIN	123	75	73	—	48	18	2
	3	□	1620S-DIN-C	123	75	73	—	48	18	1
	5	□	1620L-DIN	143	95	93	—	48	18	2
	5	□	1620L-DIN-C	143	95	93	—	48	18	1
	3	□	1620X3DB	148	89	86	—	59	18	1
	5	□	1620X5DB	182	123	119	—	59	18	1
16.3	3	□	1630S-DIN	123	75	73	—	48	18	2
	3	□	1630S-DIN-C	123	75	73	—	48	18	1
	5	□	1630L-DIN	143	95	93	—	48	18	2
	5	□	1630L-DIN-C	143	95	93	—	48	18	1
	3	□	1630X3DB	148	89	86	—	59	18	1
	5	□	1630X5DB	182	123	119	—	59	18	1
16.4	3	□	1640S-DIN	123	75	73	—	48	18	2
	3	□	1640S-DIN-C	123	75	73	—	48	18	1
	5	□	1640L-DIN	143	95	93	—	48	18	2
	5	□	1640L-DIN-C	143	95	93	—	48	18	1
	3	□	1640X3DB	148	89	86	—	59	18	1
	5	□	1640X5DB	182	123	119	—	59	18	1
16.5	3	●	1650S-DIN	123	75	73	—	48	18	2
	3	□	1650S-DIN-C	123	75	73	—	48	18	1
	5	●	1650L-DIN	143	95	93	—	48	18	2
	5	□	1650L-DIN-C	143	95	93	—	48	18	1
	3	★	1650X3DB	148	89	86	—	59	18	1
	5	★	1650X5DB	182	123	119	—	59	18	1
16.6	3	□	1660S-DIN	123	75	73	—	48	18	2
	3	□	1660S-DIN-C	123	75	73	—	48	18	1
	5	□	1660L-DIN	143	95	93	—	48	18	2
	5	□	1660L-DIN-C	143	95	93	—	48	18	1
	3	□	1660X3DB	148	89	88	—	59	18	1
	5	□	1660X5DB	182	123	122	—	59	18	1
16.7	3	□	1670S-DIN	123	75	73	—	48	18	2
	3	□	1670S-DIN-C	123	75	73	—	48	18	1
	5	□	1670L-DIN	143	95	93	—	48	18	2
	5	□	1670L-DIN-C	143	95	93	—	48	18	1
	3	□	1670X3DB	148	89	88	—	59	18	1
	5	□	1670X5DB	182	123	122	—	59	18	1
16.8	3	□	1680S-DIN	123	75	73	—	48	18	2
	3	□	1680S-DIN-C	123	75	73	—	48	18	1
	5	□	1680L-DIN	143	95	93	—	48	18	2
	5	□	1680L-DIN-C	143	95	93	—	48	18	1
	3	□	1680X3DB	148	89	88	—	59	18	1
	5	□	1680X5DB	182	123	122	—	59	18	1
16.9	3	□	1690S-DIN	123	75	73	—	48	18	2
	3	□	1690S-DIN-C	123	75	73	—	48	18	1
	5	□	1690L-DIN	143	95	93	—	48	18	2
	5	□	1690L-DIN-C	143	95	93	—	48	18	1
	3	□	1690X3DB	148	89	88	—	59	18	1
	5	□	1690X5DB	182	123	122	—	59	18	1

Диам. сверла D1 (мм)	Глубина сверления (l/d)	Наличие DP7020	Обозначение	Размеры (мм)						Тип
				L1	L2	L3	L6	L9	D4	
17.0	3	●	MMS1700S-DIN	123	75	73	—	48	18	2
	3	□	1700S-DIN-C	123	75	73	—	48	18	1
	5	●	1700L-DIN	143	95	93	—	48	18	2
	5	□	1700L-DIN-C	143	95	93	—	48	18	1
	3	★	1700X3DB	148	89	88	—	59	18	1
	5	★	1700X5DB	182	123	122	—	59	18	1
17.1	3	□	1710S-DIN	123	75	73	—	48	18	2
	3	□	1710S-DIN-C	123	75	73	—	48	18	1
	5	□	1710L-DIN	143	95	93	—	48	18	2
	5	□	1710L-DIN-C	143	95	93	—	48	18	1
	3	□	1710X3DB	152	93	91	—	59	18	1
	5	□	1710X5DB	188	129	126	—	59	18	1
17.2	3	□	1720S-DIN	123	75	73	—	48	18	2
	3	□	1720S-DIN-C	123	75	73	—	48	18	1
	5	□	1720L-DIN	143	95	93	—	48	18	2
	5	□	1720L-DIN-C	143	95	93	—	48	18	1
	3	□	1720X3DB	152	93	91	—	59	18	1
	5	□	1720X5DB	188	129	126	—	59	18	1
17.3	3	□	1730S-DIN	123	75	73	—	48	18	2
	3	□	1730S-DIN-C	123	75	73	—	48	18	1
	5	□	1730L-DIN	143	95	93	—	48	18	2
	5	□	1730L-DIN-C	143	95	93	—	48	18	1
	3	□	1730X3DB	152	93	91	—	59	18	1
	5	□	1730X5DB	188	129	126	—	59	18	1
17.4	3	□	1740S-DIN	123	75	73	—	48	18	2
	3	□	1740S-DIN-C	123	75	73	—	48	18	1
	5	□	1740L-DIN	143	95	93	—	48	18	2
	5	□	1740L-DIN-C	143	95	93	—	48	18	1
	3	□	1740X3DB	152	93	91	—	59	18	1
	5	□	1740X5DB	188	129	126	—	59	18	1
17.5	3	●	1750S-DIN	123	75	73	—	48	18	2
	3	□	1750S-DIN-C	123	75	73	—	48	18	1
	5	●	1750L-DIN	143	95	93	—	48	18	2
	5	□	1750L-DIN-C	143	95	93	—	48	18	1
	3	★	1750X3DB	152	93	91	—	59	18	1
	5	★	1750X5DB	188	129	126	—	59	18	1
17.6	3	□	1760S-DIN	123	75	73	—	48	18	2
	3	□	1760S-DIN-C	123	75	73	—	48	18	1
	5	□	1760L-DIN	143	95	93	—	48	18	2
	5	□	1760L-DIN-C	143	95	93	—	48	18	1
	3	□	1760X3DB	152	93	93	—	59	18	1
	5	□	1760X5DB	188	129	129	—	59	18	1
17.7	3	□	1770S-DIN	123	75	73	—	48	18	2
	3	□	1770S-DIN-C	123	75	73	—	48	18	1
	5	□	1770L-DIN	143	95	93	—	48	18	2
	5	□	1770L-DIN-C	143	95	93	—	48	18	1
	3	□	1770X3DB	152	93	93	—	59	18	1
	5	□	1770X5DB	188	129	129	—	59	18	1

# СВЕРЛЕНИЕ (МОНОЛИТНЫЕ ТВЕРДОСПЛАВНЫЕ СВЕРЛА)

# MMS

ТВЕРДЫЙ  
СПЛАВ

Диам. сверла D1 (мм)	Глубина сверления (l/d)	Наличие DP7020	Обозначение	Размеры (мм)						Тип
				L1	L2	L3	L6	L9	D4	
17.8	3	□	MMS1780S-DIN	123	75	73	—	48	18	2
	3	□	1780S-DIN-C	123	75	73	—	48	18	1
	5	□	1780L-DIN	143	95	93	—	48	18	2
	5	□	1780L-DIN-C	143	95	93	—	48	18	1
	3	□	1780X3DB	152	93	93	—	59	18	1
	5	□	1780X5DB	188	129	129	—	59	18	1
17.9	3	□	1790S-DIN	123	75	73	—	48	18	2
	3	□	1790S-DIN-C	123	75	73	—	48	18	1
	5	□	1790L-DIN	143	95	93	—	48	18	2
	5	□	1790L-DIN-C	143	95	93	—	48	18	1
	3	□	1790X3DB	152	93	93	—	59	18	1
	5	□	1790X5DB	188	129	129	—	59	18	1
18.0	3	●	1800S-DIN	123	75	73	—	48	18	2
	3	□	1800S-DIN-C	123	75	73	—	48	18	1
	5	●	1800L-DIN	143	95	93	—	48	18	2
	5	□	1800L-DIN-C	143	95	93	—	48	18	1
	3	★	1800X3DB	152	93	93	—	59	18	1
	5	★	1800X5DB	188	129	129	—	59	18	1
18.1	3	□	1810S-DIN	131	81	79	—	50	20	2
	3	□	1810S-DIN-C	131	81	79	—	50	20	1
	5	□	1810L-DIN	153	103	101	—	50	20	2
	5	□	1810L-DIN-C	153	103	101	—	50	20	1
	3	□	1810X3DB	160	99	96	—	61	20	1
	5	□	1810X5DB	198	137	133	—	61	20	1
18.2	3	□	1820S-DIN	131	81	79	—	50	20	2
	3	□	1820S-DIN-C	131	81	79	—	50	20	1
	5	□	1820L-DIN	153	103	101	—	50	20	2
	5	□	1820L-DIN-C	153	103	101	—	50	20	1
	3	□	1820X3DB	160	99	96	—	61	20	1
	5	□	1820X5DB	198	137	133	—	61	20	1
18.3	3	□	1830S-DIN	131	81	79	—	50	20	2
	3	□	1830S-DIN-C	131	81	79	—	50	20	1
	5	□	1830L-DIN	153	103	101	—	50	20	2
	5	□	1830L-DIN-C	153	103	101	—	50	20	1
	3	□	1830X3DB	160	99	96	—	61	20	1
	5	□	1830X5DB	198	137	133	—	61	20	1
18.4	3	□	1840S-DIN	131	81	79	—	50	20	2
	3	□	1840S-DIN-C	131	81	79	—	50	20	1
	5	□	1840L-DIN	153	103	101	—	50	20	2
	5	□	1840L-DIN-C	153	103	101	—	50	20	1
	3	□	1840X3DB	160	99	96	—	61	20	1
	5	□	1840X5DB	198	137	133	—	61	20	1
18.5	3	●	1850S-DIN	131	81	79	—	50	20	2
	3	□	1850S-DIN-C	131	81	79	—	50	20	1
	5	●	1850L-DIN	153	103	101	—	50	20	2
	5	□	1850L-DIN-C	153	103	101	—	50	20	1
	3	★	1850X3DB	160	99	96	—	61	20	1
	5	★	1850X5DB	198	137	133	—	61	20	1

Диам. сверла D1 (мм)	Глубина сверления (l/d)	Наличие DP7020	Обозначение	Размеры (мм)						Тип
				L1	L2	L3	L6	L9	D4	
18.6	3	□	MMS1860S-DIN	131	81	79	—	50	20	2
	3	□	1860S-DIN-C	131	81	79	—	50	20	1
	5	□	1860L-DIN	153	103	101	—	50	20	2
	5	□	1860L-DIN-C	153	103	101	—	50	20	1
	3	□	1860X3DB	160	99	98	—	61	20	1
	5	□	1860X5DB	198	137	136	—	61	20	1
18.7	3	□	1870S-DIN	131	81	79	—	50	20	2
	3	□	1870S-DIN-C	131	81	79	—	50	20	1
	5	□	1870L-DIN	153	103	101	—	50	20	2
	5	□	1870L-DIN-C	153	103	101	—	50	20	1
	3	□	1870X3DB	160	99	98	—	61	20	1
	5	□	1870X5DB	198	137	136	—	61	20	1
18.8	3	□	1880S-DIN	131	81	79	—	50	20	2
	3	□	1880S-DIN-C	131	81	79	—	50	20	1
	5	□	1880L-DIN	153	103	101	—	50	20	2
	5	□	1880L-DIN-C	153	103	101	—	50	20	1
	3	□	1880X3DB	160	99	98	—	61	20	1
	5	□	1880X5DB	198	137	136	—	61	20	1
18.9	3	□	1890S-DIN	131	81	79	—	50	20	2
	3	□	1890S-DIN-C	131	81	79	—	50	20	1
	5	□	1890L-DIN	153	103	101	—	50	20	2
	5	□	1890L-DIN-C	153	103	101	—	50	20	1
	3	□	1890X3DB	160	99	98	—	61	20	1
	5	□	1890X5DB	198	137	136	—	61	20	1
19.0	3	●	1900S-DIN	131	81	79	—	50	20	2
	3	□	1900S-DIN-C	131	81	79	—	50	20	1
	5	●	1900L-DIN	153	103	101	—	50	20	2
	5	□	1900L-DIN-C	153	103	101	—	50	20	1
	3	★	1900X3DB	160	99	98	—	61	20	1
	5	★	1900X5DB	198	137	136	—	61	20	1
19.1	3	□	1910S-DIN	131	81	79	—	50	20	2
	3	□	1910S-DIN-C	131	81	79	—	50	20	1
	5	□	1910L-DIN	153	103	101	—	50	20	2
	5	□	1910L-DIN-C	153	103	101	—	50	20	1
	3	□	1910X3DB	164	103	101	—	61	20	1
	5	□	1910X5DB	204	143	140	—	61	20	1
19.2	3	□	1920S-DIN	131	81	79	—	50	20	2
	3	□	1920S-DIN-C	131	81	79	—	50	20	1
	5	□	1920L-DIN	153	103	101	—	50	20	2
	5	□	1920L-DIN-C	153	103	101	—	50	20	1
	3	□	1920X3DB	164	103	101	—	61	20	1
	5	□	1920X5DB	204	143	140	—	61	20	1
19.3	3	□	1930S-DIN	131	81	79	—	50	20	2
	3	□	1930S-DIN-C	131	81	79	—	50	20	1
	5	□	1930L-DIN	153	103	101	—	50	20	2
	5	□	1930L-DIN-C	153	103	101	—	50	20	1
	3	□	1930X3DB	164	103	101	—	61	20	1
	5	□	1930X5DB	204	143	140	—	61	20	1

СВЕРЛЕНИЕ

● : Есть на складе. ★ : Со склада в Японии.

□ : Нет на складе, выпускается исключительно под заказ.

L068

Диам. сверла D1 (мм)	Глубина сверления (l/d)	Наличие DP7020	Обозначение	Размеры (мм)						Тип
				L1	L2	L3	L6	L9	D4	
19.4	3	□	MMS1940S-DIN	131	81	79	—	50	20	2
	3	□	1940S-DIN-C	131	81	79	—	50	20	1
	5	□	1940L-DIN	153	103	101	—	50	20	2
	5	□	1940L-DIN-C	153	103	101	—	50	20	1
	3	□	1940X3DB	164	103	101	—	61	20	1
	5	□	1940X5DB	204	143	140	—	61	20	1
19.5	3	●	1950S-DIN	131	81	79	—	50	20	2
	3	□	1950S-DIN-C	131	81	79	—	50	20	1
	5	●	1950L-DIN	153	103	101	—	50	20	2
	5	□	1950L-DIN-C	153	103	101	—	50	20	1
	3	★	1950X3DB	164	103	101	—	61	20	1
	5	★	1950X5DB	204	143	140	—	61	20	1
19.6	3	□	1960S-DIN	131	81	79	—	50	20	2
	3	□	1960S-DIN-C	131	81	79	—	50	20	1
	5	□	1960L-DIN	153	103	101	—	50	20	2
	5	□	1960L-DIN-C	153	103	101	—	50	20	1
	3	□	1960X3DB	165	104	104	—	61	20	1
	5	□	1960X5DB	205	144	144	—	61	20	1
19.7	3	□	1970S-DIN	131	81	79	—	50	20	2
	3	□	1970S-DIN-C	131	81	79	—	50	20	1
	5	□	1970L-DIN	153	103	101	—	50	20	2

Диам. сверла D1 (мм)	Глубина сверления (l/d)	Наличие DP7020	Обозначение	Размеры (мм)						Тип
				L1	L2	L3	L6	L9	D4	
19.7	5	□	MMS1970L-DIN-C	153	103	101	—	50	20	1
	3	□	1970X3DB	165	104	104	—	61	20	1
	5	□	1970X5DB	205	144	144	—	61	20	1
19.8	3	□	1980S-DIN	131	81	79	—	50	20	2
	3	□	1980S-DIN-C	131	81	79	—	50	20	1
	5	□	1980L-DIN	153	103	101	—	50	20	2
	5	□	1980L-DIN-C	153	103	101	—	50	20	1
	3	□	1980X3DB	165	104	104	—	61	20	1
19.9	5	□	1980X5DB	205	144	144	—	61	20	1
	3	□	1990S-DIN	131	81	79	—	50	20	2
	3	□	1990S-DIN-C	131	81	79	—	50	20	1
	5	□	1990L-DIN	153	103	101	—	50	20	2
	5	□	1990L-DIN-C	153	103	101	—	50	20	1
20.0	3	□	1990X3DB	165	104	104	—	61	20	1
	5	□	1990X5DB	205	144	144	—	61	20	1
	3	●	2000S-DIN	131	81	79	—	50	20	2
	3	□	2000S-DIN-C	131	81	79	—	50	20	1
	5	●	2000L-DIN	153	103	101	—	50	20	2
20.0	5	□	2000L-DIN-C	153	103	101	—	50	20	1
	3	★	2000X3DB	165	104	104	—	61	20	1
	5	★	2000X5DB	205	144	144	—	61	20	1

## ИНСТРУКЦИЯ ПО ЭКСПЛУАТАЦИИ

### Крепление сверла

Регулируемый винт

Цанговый патрон с упорным подшипником надежно держит сверло.

### Длина сверла

$A \geq D1 \times 1.5$

### Установка сверла

Не прижимать по режущей кромке.

### Допуск на установку

Биение  $\leq 0.03\text{мм}$

### Тип охлаждения через сквозные отверстия

Тип охлаждения через шпиндель

Тип охлаждения на вращающийся шпиндель станка

Давление охлаждающей среды должно составлять ок. 0.5–7МПа

### Рекомендации по использованию СОЖ

- 1) Рекомендуется регулярно проводить замену СОЖ во избежание забивания каналов в сверле.
- 2) Для предотвращения забивания мелкой стружкой отверстий сверла используйте фильтр, как профилактическую меру. Для сверл малого диаметра рекомендуется применять фильтр с более мелкими отверстиями.

### Тонкая заготовка

Если наблюдается отгиб.

Необходима опора для заготовки.

### Прерывистое резание

Один процесс

① Уменьшить подачу при сверлении ступенчатой детали (при прерывистом сверлении).

Требуется предварительная обработка.

① До сверления предварительно подрезать торец концевой фрезой.

### РЕКОМЕНДУЕМЫЕ РЕЖИМЫ РЕЗАНИЯ

Обрабатываемый материал	Аустенитная нержавеющая сталь ( $\leq 180\text{HB}$ )				Аустенитная нержавеющая сталь ( $180-280\text{HB}$ )			
	X5CrNi1810, X5CrNiMo17-12-2				X2CrNi1810, X2CrNiMoN17-12-2			
Диам. сверла (мм)	Скорость резания (м/мин)	Частота вращения ( $\text{мин}^{-1}$ )	Подача (мин.—макс.) (мм/об)	Подача (мм/мин)	Скорость резания (м/мин)	Частота вращения ( $\text{мин}^{-1}$ )	Подача (мин.—макс.) (мм/об)	Подача (мм/мин)
3.2	80	7900	0.13 (0.08—0.18)	1025	60	5900	0.1 (0.05—0.15)	590
4.0	80	6300	0.15 (0.10—0.20)	945	60	4700	0.12 (0.08—0.18)	560
5.0	80	5000	0.15 (0.10—0.20)	750	60	3800	0.12 (0.08—0.18)	455
6.3	80	4000	0.17 (0.12—0.22)	680	60	3000	0.15 (0.1—0.2)	450
8.0	80	3100	0.19 (0.14—0.24)	585	60	2300	0.17 (0.12—0.22)	390
10.0	60	1900	0.2 (0.15—0.25)	380	50	1500	0.18 (0.13—0.23)	270
12.0	60	1500	0.21 (0.16—0.26)	315	50	1300	0.19 (0.14—0.24)	245
16.0	60	1100	0.22 (0.17—0.27)	240	50	900	0.2 (0.15—0.25)	180
20.0	60	900	0.23 (0.18—0.28)	205	50	700	0.21 (0.16—0.26)	145

Обрабатываемый материал	Two-phase Stainless Steel ( $\leq 280\text{HB}$ )				Ferritic and Martensitic Stainless Steel ( $\leq 200\text{HB}$ )			
	X3CrNiMoN27-5-2				X10Cr13, X6Cr17			
Диам. сверла (мм)	Скорость резания (м/мин)	Частота вращения ( $\text{мин}^{-1}$ )	Подача (мин.—макс.) (мм/об)	Подача (мм/мин)	Скорость резания (м/мин)	Частота вращения ( $\text{мин}^{-1}$ )	Подача (мин.—макс.) (мм/об)	Подача (мм/мин)
3.2	50	4900	0.1 (0.05—0.15)	490	80	7900	0.13 (0.08—0.18)	1025
4.0	50	3900	0.12 (0.08—0.18)	465	80	6300	0.15 (0.10—0.20)	945
5.0	50	3100	0.12 (0.08—0.18)	370	80	5000	0.15 (0.10—0.20)	750
6.3	50	2500	0.15 (0.1—0.2)	375	80	4000	0.17 (0.12—0.22)	680
8.0	50	1900	0.17 (0.12—0.22)	320	80	3100	0.19 (0.14—0.24)	585
10.0	40	1200	0.18 (0.13—0.23)	215	60	1900	0.2 (0.15—0.25)	380
12.0	40	1000	0.19 (0.14—0.24)	190	60	1500	0.21 (0.16—0.26)	315
16.0	40	700	0.2 (0.15—0.25)	140	60	1100	0.22 (0.17—0.27)	240
20.0	40	600	0.21 (0.16—0.26)	125	60	900	0.23 (0.18—0.28)	205

Обрабатываемый материал	Ferritic and Martensitic Stainless Steel ( $>200\text{HB}$ )				Hardened Stainless Steel ( $<450\text{HB}$ )			
	X20CrNi17-2, X30Cr13				X5CrNiCuNb164, X7CrNiAl177, 17-4PH, 17-7PH			
Диам. сверла (мм)	Скорость резания (м/мин)	Частота вращения ( $\text{мин}^{-1}$ )	Подача (мин.—макс.) (мм/об)	Подача (мм/мин)	Скорость резания (м/мин)	Частота вращения ( $\text{мин}^{-1}$ )	Подача (мин.—макс.) (мм/об)	Подача (мм/мин)
3.2	60	5900	0.1 (0.05—0.15)	590	50	4900	0.1 (0.05—0.15)	490
4.0	60	4700	0.12 (0.08—0.18)	560	50	3900	0.12 (0.08—0.18)	465
5.0	60	3800	0.12 (0.08—0.18)	455	50	3100	0.12 (0.08—0.18)	370
6.3	60	3000	0.15 (0.1—0.2)	450	50	2500	0.15 (0.1—0.2)	375
8.0	60	2300	0.17 (0.12—0.22)	390	50	1900	0.17 (0.12—0.22)	320
10.0	50	1500	0.18 (0.13—0.23)	270	40	1200	0.18 (0.13—0.23)	215
12.0	50	1300	0.19 (0.14—0.24)	245	40	1000	0.19 (0.14—0.24)	190
16.0	50	900	0.2 (0.15—0.25)	180	40	700	0.2 (0.15—0.25)	140
20.0	50	700	0.21 (0.16—0.26)	145	40	600	0.21 (0.16—0.26)	125

(Примечание 1) Для стабильного сверления рекомендуется подавать СОЖ под высоким давлением.

(Примечание 2) В качестве охлаждающего средства рекомендуется эмульсия.

(Примечание 3) При использовании водонерастворимой СОЖ рекомендуется снизить частоту вращения на 10—20%.

## ТАБЛИЦА СРАВНЕНИЯ МАТЕРИАЛОВ ДЛЯ НЕРЖАВЕЮЩИХ СТАЛЕЙ

Обрабатываемый материал	№	Германия		США	Япония
		W-но.	DIN	AIS/SAE	JIS
Ферритная и мартенситная нержавеющая сталь	1	1.4005	X12CrS3	416	SUS416
		1.4006	X10Cr13	410	SUS410
		1.4016	X6Cr17	430	SUS430
		1.4113	X6CrMo17	434	SUS434
		1.4510	X6CrTi17	430Ti	SUS430LX
		1.4512	X6CrTi12	409	
	2	1.4021	X20Cr13	420	SUS420J1
		1.4057	X20CrNi17-2	431	SUS431
		1.4028	X30Cr13	420	SUS420J2
		1.4125	X10CrMo17	440C	SUS440C
Нержавеющая сталь PH	3	1.4542	X5CrNiCuNb16 4	630 (17-4PH)	SUS630
		1.4545		S15500 (15-5PH)	
		1.4568	X7CrNiAl17 7	631 (17-7PH)	SUS631
Аустенитная нержавеющая сталь	4	1.4301	X5CrNi18 10	304	SUS304
		1.4303	X5CrNi8-12	305	SUS305
		1.4305	X12CrNiS18-9	303	SUS303
		1.4307	X2CrNi19-11	304L	SUS304L
		1.4401	X5CrNiMo17 12 2	316	SUS316
	5	1.4311	X2CrNiN18 10	304LN	SUS304LN
		1.4404	X2CrNiMo17 12 2	316L	SUS316L
		1.4406	X2CrNiMoN17 12 2	316LN	SUS316LN
		1.4435	X2CrNiMo18 14 3		SUS316L
		1.4438	X2CrNiMo18 15 4	317L	SUS317L
		1.4529	X1NiCrMoCuN25 20 7	N08926	
		1.4541	X6CrNiTi18-10	321	SUS321
		1.4550	X6CrNiNb18-10	347	SUS347
		1.4571	X6CrNiMoTi17 12 2	316Ti	SUS316Ti
		Дуплексная сталь	6	1.4362	X2CrNiN23 4
1.4410	X2CrNiMoN25 7 4			S32750	SCS14A
1.4460	X3CrNiMoN27 5 2			329	SUS329J1
1.4462	X2CrNiMoN22 5 3			S31803	SUS329J3L

# СВЕРЛЕНИЕ (МОНОЛИТНЫЕ ТВЕРДОСПЛАВНЫЕ СВЕРЛА)

## MNS

ТВЕРДЫЙ СПЛАВ

Углеродистая сталь Легированная сталь	Закалённая сталь	Нержавеющая сталь	Чугун	Лёгкий сплав	Жаропрочные сплавы
--	------------------	-------------------	-------	--------------	--------------------

	D1=3	3<D1≤6	6<D1≤10	10<D1≤18	18<D1≤20
DIN Тип	+0.016 +0.004	+0.016 +0.004	+0.021 +0.006	+0.025 +0.007	+0.029 +0.008
Прочее	0 -0.014	0 -0.018	0 -0.022	0 -0.027	0 -0.013
h6	0 -0.006	0 -0.008	0 -0.009	0 -0.011	0 -0.013



● Сверла диаметром 4.5 мм и менее имеют только 2 отверстия для подачи СОЖ.

● Тип 1 MNS---DIN-C, MNS-C, MNS---LB, MNS---DB (Цилиндрический хвостик)

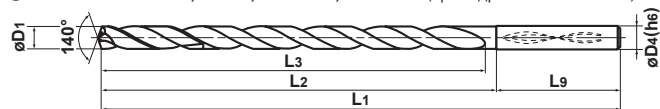

● Тип 2 MNS---S/L-DIN (Хвостик с лыской)

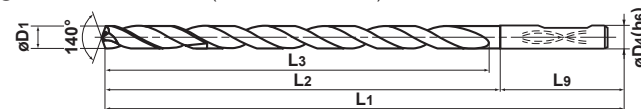

(Примечание) Сверла MNS предназначены для использования с термоматрицами.

Диам. сверла D1 (мм)	Глубина сверления (l/d)	Наличие TF15	Обозначение	Размеры (мм)					Тип
				L1	L2	L3	L9	D4	
3.0	3	□	MNS0300S-DIN	62	26	20	36	6	2
	3	□	0300S-DIN-C	62	26	20	36	6	1
	5	□	0300L-DIN	66	30	28	36	6	2
	5	●	0300L-DIN-C	66	30	28	36	6	1
	8	□	0300-L8C	74	38	34	36	6	1
	10	□	0300-L10C	80	44	40	36	6	1
	12	●	0300-L12C	86	50	46	36	6	1
	15	□	0300-L15C	95	59	55	36	6	1
	20	●	0300-L20C	110	74	70	36	6	1
	25	□	0300-L25C	125	89	85	36	6	1
	30	●	0300-L30C	140	104	100	36	6	1
	5	★	0300LB	81	33	33	48	3	1
10	★	0300X10DB	90	42	39	48	3	1	
20	★	0300X20DB	120	72	69	48	3	1	
30	★	0300X30DB	150	102	99	48	3	1	
3.1	3	□	0310S-DIN	62	26	20	36	6	2
	3	□	0310S-DIN-C	62	26	20	36	6	1
	5	□	0310L-DIN	66	30	28	36	6	2
	5	□	0310L-DIN-C	66	30	28	36	6	1
	8	□	0310-L8C	80	44	40	36	6	1
	10	□	0310-L10C	87	51	47	36	6	1
	12	□	0310-L12C	94	58	54	36	6	1
	15	□	0310-L15C	104	68	64	36	6	1
	20	□	0310-L20C	122	86	82	36	6	1
	25	□	0310-L25C	139	103	99	36	6	1
	30	□	0310-L30C	157	121	117	36	6	1
	5	★	0310LB	87	39	39	48	4	1
10	□	0310X10DB	97	49	46	48	4	1	
20	□	0310X20DB	132	84	81	48	4	1	
30	□	0310X30DB	167	119	116	48	4	1	
3.2	3	□	0320S-DIN	62	26	20	36	6	2
	3	□	0320S-DIN-C	62	26	20	36	6	1
	5	□	0320L-DIN	66	30	28	36	6	2
	5	●	0320L-DIN-C	66	30	28	36	6	1
	8	□	0320-L8C	80	44	40	36	6	1
	10	□	0320-L10C	87	51	47	36	6	1
	12	●	0320-L12C	94	58	54	36	6	1
	15	□	0320-L15C	104	68	64	36	6	1
	20	□	0320-L20C	122	86	82	36	6	1
	25	□	0320-L25C	139	103	99	36	6	1
	30	□	0320-L30C	157	121	117	36	6	1
	5	★	0320LB	87	39	39	48	4	1
10	★	0320X10DB	97	49	46	48	4	1	
20	★	0320X20DB	132	84	81	48	4	1	
30	★	0320X30DB	167	119	116	48	4	1	

Диам. сверла D1 (мм)	Глубина сверления (l/d)	Наличие TF15	Обозначение	Размеры (мм)					Тип
				L1	L2	L3	L9	D4	
3.2	20	●	MNS0320-L20C	122	86	82	36	6	1
	25	□	0320-L25C	139	103	99	36	6	1
	30	●	0320-L30C	157	121	117	36	6	1
	5	★	0320LB	87	39	39	48	4	1
	10	★	0320X10DB	97	49	46	48	4	1
	20	★	0320X20DB	132	84	81	48	4	1
	30	★	0320X30DB	167	119	116	48	4	1
3.3	3	□	0330S-DIN	62	26	20	36	6	2
	3	□	0330S-DIN-C	62	26	20	36	6	1
	5	□	0330L-DIN	66	30	28	36	6	2
	5	●	0330L-DIN-C	66	30	28	36	6	1
	8	□	0330-L8C	80	44	40	36	6	1
	10	□	0330-L10C	87	51	47	36	6	1
	12	●	0330-L12C	94	58	54	36	6	1
	15	□	0330-L15C	104	68	64	36	6	1
	20	●	0330-L20C	122	86	82	36	6	1
	25	□	0330-L25C	139	103	99	36	6	1
	30	●	0330-L30C	157	121	117	36	6	1
	5	★	0330LB	87	39	39	48	4	1
10	□	0330X10DB	97	49	46	48	4	1	
20	□	0330X20DB	132	84	81	48	4	1	
30	□	0330X30DB	167	119	116	48	4	1	
3.4	3	□	0340S-DIN	62	26	20	36	6	2
	3	□	0340S-DIN-C	62	26	20	36	6	1
	5	□	0340L-DIN	66	30	28	36	6	2
	5	□	0340L-DIN-C	66	30	28	36	6	1
	8	□	0340-L8C	80	44	40	36	6	1
	10	□	0340-L10C	87	51	47	36	6	1
	12	□	0340-L12C	94	58	54	36	6	1
	15	□	0340-L15C	104	68	64	36	6	1
	20	□	0340-L20C	122	86	82	36	6	1
	25	□	0340-L25C	139	103	99	36	6	1
	30	□	0340-L30C	157	121	117	36	6	1
	5	★	0340LB	87	39	39	48	4	1
10	★	0340X10DB	97	49	46	48	4	1	
20	★	0340X20DB	132	84	81	48	4	1	
30	★	0340X30DB	167	119	116	48	4	1	

(Примечание) Пожалуйста, свяжитесь с нами если Вы не нашли нужную геометрию в данном каталоге (могут быть заказаны другие диаметры и длины).

● : Есть на складе. ★ : Со склада в Японии.

□ : Нет на складе, выпускается исключительно под заказ.

L072

СВЕРЛЕНИЕ

Диам. сверла D1 (мм)	Глубина сверления (l/d)	Наличие TF15	Обозначение	Размеры (мм)					Тип
				L1	L2	L3	L9	D4	
3.5	3	□	MNS0350S-DIN	62	26	20	36	6	2
	3	□	0350S-DIN-C	62	26	20	36	6	1
	5	□	0350L-DIN	66	30	28	36	6	2
	5	●	0350L-DIN-C	66	30	28	36	6	1
	8	□	0350-L8C	80	44	40	36	6	1
	10	□	0350-L10C	87	51	47	36	6	1
	12	●	0350-L12C	94	58	54	36	6	1
	15	□	0350-L15C	104	68	64	36	6	1
	20	●	0350-L20C	122	86	82	36	6	1
	25	□	0350-L25C	139	103	99	36	6	1
	30	●	0350-L30C	157	121	117	36	6	1
	5	★	0350LB	87	39	39	48	4	1
	10	□	0350X10DB	97	49	46	48	4	1
	20	□	0350X20DB	132	84	81	48	4	1
30	□	0350X30DB	167	119	116	48	4	1	
3.6	3	□	0360S-DIN	62	26	20	36	6	2
	3	□	0360S-DIN-C	62	26	20	36	6	1
	5	□	0360L-DIN	66	30	28	36	6	2
	5	□	0360L-DIN-C	66	30	28	36	6	1
	8	□	0360-L8C	85	49	45	36	6	1
	10	□	0360-L10C	93	57	53	36	6	1
	12	□	0360-L12C	101	65	61	36	6	1
	15	□	0360-L15C	113	77	73	36	6	1
	20	□	0360-L20C	133	97	93	36	6	1
	25	□	0360-L25C	153	117	113	36	6	1
	30	□	0360-L30C	173	137	133	36	6	1
	5	★	0360LB	92	44	44	48	4	1
	10	★	0360X10DB	103	55	52	48	4	1
	20	★	0360X20DB	143	95	92	48	4	1
30	★	0360X30DB	183	135	132	48	4	1	
3.7	3	□	0370S-DIN	62	26	20	36	6	2
	3	□	0370S-DIN-C	62	26	20	36	6	1
	5	□	0370L-DIN	66	30	28	36	6	2
	5	□	0370L-DIN-C	66	30	28	36	6	1
	8	□	0370-L8C	85	49	45	36	6	1
	10	□	0370-L10C	93	57	53	36	6	1
	12	□	0370-L12C	101	65	61	36	6	1
	15	□	0370-L15C	113	77	73	36	6	1
	20	□	0370-L20C	133	97	93	36	6	1
	25	□	0370-L25C	153	117	113	36	6	1
	30	□	0370-L30C	173	137	133	36	6	1
	5	★	0370LB	92	44	44	48	4	1
	10	□	0370X10DB	103	55	52	48	4	1
	20	□	0370X20DB	143	95	92	48	4	1
30	□	0370X30DB	183	135	132	48	4	1	

Диам. сверла D1 (мм)	Глубина сверления (l/d)	Наличие TF15	Обозначение	Размеры (мм)					Тип
				L1	L2	L3	L9	D4	
3.8	3	□	MNS0380S-DIN	66	30	24	36	6	2
	3	□	0380S-DIN-C	66	30	24	36	6	1
	5	□	0380L-DIN	74	38	36	36	6	2
	5	□	0380L-DIN-C	74	38	36	36	6	1
	8	□	0380-L8C	85	49	45	36	6	1
	10	□	0380-L10C	93	57	53	36	6	1
	12	□	0380-L12C	101	65	61	36	6	1
	15	□	0380-L15C	113	77	73	36	6	1
	20	□	0380-L20C	133	97	93	36	6	1
	25	□	0380-L25C	153	117	113	36	6	1
	30	□	0380-L30C	173	137	133	36	6	1
	5	★	0380LB	92	44	44	48	4	1
	10	□	0380X10DB	103	55	52	48	4	1
	20	□	0380X20DB	143	95	92	48	4	1
30	□	0380X30DB	183	135	132	48	4	1	
3.9	3	□	0390S-DIN	66	30	24	36	6	2
	3	□	0390S-DIN-C	66	30	24	36	6	1
	5	□	0390L-DIN	74	38	36	36	6	2
	5	□	0390L-DIN-C	74	38	36	36	6	1
	8	□	0390-L8C	85	49	45	36	6	1
	10	□	0390-L10C	93	57	53	36	6	1
	12	□	0390-L12C	101	65	61	36	6	1
	15	□	0390-L15C	113	77	73	36	6	1
	20	□	0390-L20C	133	97	93	36	6	1
	25	□	0390-L25C	153	117	113	36	6	1
	30	□	0390-L30C	173	137	133	36	6	1
	5	★	0390LB	92	44	44	48	4	1
	10	★	0390X10DB	103	55	52	48	4	1
	20	★	0390X20DB	143	95	92	48	4	1
30	★	0390X30DB	183	135	132	48	4	1	
4.0	3	□	0400S-DIN	66	30	24	36	6	2
	3	□	0400S-DIN-C	66	30	24	36	6	1
	5	□	0400L-DIN	74	38	36	36	6	2
	5	●	0400L-DIN-C	74	38	36	36	6	1
	8	□	0400-L8C	85	49	45	36	6	1
	10	□	0400-L10C	93	57	53	36	6	1
	12	●	0400-L12C	101	65	61	36	6	1
	15	□	0400-L15C	113	77	73	36	6	1
	20	●	0400-L20C	133	97	93	36	6	1
	25	●	0400-L25C	153	117	113	36	6	1
	30	●	0400-L30C	173	137	133	36	6	1
	5	★	0400LB	92	44	44	48	4	1
	10	★	0400X10DB	103	55	52	48	4	1
	20	★	0400X20DB	143	95	92	48	4	1
30	★	0400X30DB	183	135	132	48	4	1	

# СВЕРЛЕНИЕ (МОНОЛИТНЫЕ ТВЕРДОСПЛАВНЫЕ СВЕРЛА)

## MNS

ТВЕРДЫЙ  
СПЛАВ

Диам. сверла D1 (мм)	Глубина сверления (l/d)	Наличие TF15	Обозначение	Размеры (мм)					Тип
				L1	L2	L3	L9	D4	
4.1	3	<input type="checkbox"/>	MNS0410S-DIN	66	30	24	36	6	2
	3	<input type="checkbox"/>	0410S-DIN-C	66	30	24	36	6	1
	5	<input type="checkbox"/>	0410L-DIN	74	38	36	36	6	2
	5	<input type="checkbox"/>	0410L-DIN-C	74	38	36	36	6	1
	8	<input type="checkbox"/>	0410-L8C	91	55	51	36	6	1
	10	<input type="checkbox"/>	0410-L10C	100	64	60	36	6	1
	12	<input type="checkbox"/>	0410-L12C	109	73	69	36	6	1
	15	<input type="checkbox"/>	0410-L15C	122	86	82	36	6	1
	20	<input type="checkbox"/>	0410-L20C	145	109	105	36	6	1
	25	<input type="checkbox"/>	0410-L25C	167	131	127	36	6	1
	30	<input type="checkbox"/>	0410-L30C	190	154	150	36	6	1
	5	★	0410LB	100	50	50	50	5	1
	10	<input type="checkbox"/>	0410X10DB	112	62	59	50	5	1
	20	<input type="checkbox"/>	0410X20DB	157	107	104	50	5	1
30	<input type="checkbox"/>	0410X30DB	202	152	149	50	5	1	
4.2	3	<input type="checkbox"/>	0420S-DIN	66	30	24	36	6	2
	3	<input type="checkbox"/>	0420S-DIN-C	66	30	24	36	6	1
	5	<input type="checkbox"/>	0420L-DIN	74	38	36	36	6	2
	5	●	0420L-DIN-C	74	38	36	36	6	1
	8	<input type="checkbox"/>	0420-L8C	91	55	51	36	6	1
	10	<input type="checkbox"/>	0420-L10C	100	64	60	36	6	1
	12	●	0420-L12C	109	73	69	36	6	1
	15	<input type="checkbox"/>	0420-L15C	122	86	82	36	6	1
	20	●	0420-L20C	145	109	105	36	6	1
	25	<input type="checkbox"/>	0420-L25C	167	131	127	36	6	1
	30	●	0420-L30C	190	154	150	36	6	1
	5	★	0420LB	100	50	50	50	5	1
	10	<input type="checkbox"/>	0420X10DB	112	62	59	50	5	1
	20	<input type="checkbox"/>	0420X20DB	157	107	104	50	5	1
30	<input type="checkbox"/>	0420X30DB	202	152	149	50	5	1	
4.3	3	<input type="checkbox"/>	0430S-DIN	66	30	24	36	6	2
	3	<input type="checkbox"/>	0430S-DIN-C	66	30	24	36	6	1
	5	<input type="checkbox"/>	0430L-DIN	74	38	36	36	6	2
	5	<input type="checkbox"/>	0430L-DIN-C	74	38	36	36	6	1
	8	<input type="checkbox"/>	0430-L8C	91	55	51	36	6	1
	10	<input type="checkbox"/>	0430-L10C	100	64	60	36	6	1
	12	<input type="checkbox"/>	0430-L12C	109	73	69	36	6	1
	15	<input type="checkbox"/>	0430-L15C	122	86	82	36	6	1
	20	<input type="checkbox"/>	0430-L20C	145	109	105	36	6	1
	25	<input type="checkbox"/>	0430-L25C	167	131	127	36	6	1
	30	<input type="checkbox"/>	0430-L30C	190	154	150	36	6	1
	5	★	0430LB	100	50	50	50	5	1
	10	<input type="checkbox"/>	0430X10DB	112	62	59	50	5	1
	20	<input type="checkbox"/>	0430X20DB	157	107	104	50	5	1
30	<input type="checkbox"/>	0430X30DB	202	152	149	50	5	1	

Диам. сверла D1 (мм)	Глубина сверления (l/d)	Наличие TF15	Обозначение	Размеры (мм)					Тип
				L1	L2	L3	L9	D4	
4.4	3	<input type="checkbox"/>	MNS0440S-DIN	66	30	24	36	6	2
	3	<input type="checkbox"/>	0440S-DIN-C	66	30	24	36	6	1
	5	<input type="checkbox"/>	0440L-DIN	74	38	36	36	6	2
	5	<input type="checkbox"/>	0440L-DIN-C	74	38	36	36	6	1
	8	<input type="checkbox"/>	0440-L8C	91	55	51	36	6	1
	10	<input type="checkbox"/>	0440-L10C	100	64	60	36	6	1
	12	<input type="checkbox"/>	0440-L12C	109	73	69	36	6	1
	15	<input type="checkbox"/>	0440-L15C	122	86	82	36	6	1
	20	<input type="checkbox"/>	0440-L20C	145	109	105	36	6	1
	25	<input type="checkbox"/>	0440-L25C	167	131	127	36	6	1
	30	<input type="checkbox"/>	0440-L30C	190	154	150	36	6	1
	5	★	0440LB	100	50	50	50	5	1
	10	<input type="checkbox"/>	0440X10DB	112	62	59	50	5	1
	20	<input type="checkbox"/>	0440X20DB	157	107	104	50	5	1
30	<input type="checkbox"/>	0440X30DB	202	152	149	50	5	1	
4.5	3	<input type="checkbox"/>	0450S-DIN	66	30	24	36	6	2
	3	<input type="checkbox"/>	0450S-DIN-C	66	30	24	36	6	1
	5	<input type="checkbox"/>	0450L-DIN	74	38	36	36	6	2
	5	●	0450L-DIN-C	74	38	36	36	6	1
	8	<input type="checkbox"/>	0450-L8C	91	55	51	36	6	1
	10	<input type="checkbox"/>	0450-L10C	100	64	60	36	6	1
	12	●	0450-L12C	109	73	69	36	6	1
	15	<input type="checkbox"/>	0450-L15C	122	86	82	36	6	1
	20	●	0450-L20C	145	109	105	36	6	1
	25	<input type="checkbox"/>	0450-L25C	167	131	127	36	6	1
	30	●	0450-L30C	190	154	150	36	6	1
	5	★	0450LB	100	50	50	50	5	1
	10	<input type="checkbox"/>	0450X10DB	112	62	59	50	5	1
	20	<input type="checkbox"/>	0450X20DB	157	107	104	50	5	1
30	<input type="checkbox"/>	0450X30DB	202	152	149	50	5	1	

(Примечание) Пожалуйста, свяжитесь с нами если Вы не нашли нужную геометрию в данном каталоге (могут быть заказаны другие диаметры и длины).

● : Есть на складе. ★ : Со склада в Японии.

□ : Нет на складе, выпускается исключительно под заказ.

L074

Заказ инструмента: <http://steelcam.org> | 8 (343) 382-52-03 | [sales@sverla-ekb.ru](mailto:sales@sverla-ekb.ru)

СВЕРЛЕНИЕ



● Тип 1 MNS----DIN-C, MNS-C, MNS----LB, MNS----DB (Цилиндрический хвостовик)

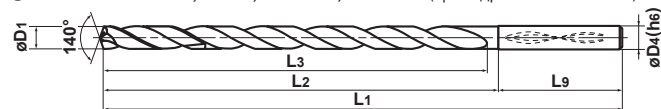

	D1=3	3<D1≤6	6<D1≤10	10<D1≤18	18<D1≤20
DIN Тип	+0.016 +0.004	+0.016 +0.004	+0.021 +0.006	+0.025 +0.007	+0.029 +0.008
Прочее	0 -0.014	0 -0.018	0 -0.022	0 -0.027	0 -0.013
h6	0 -0.006	0 -0.008	0 -0.009	0 -0.011	0 -0.013

● Тип 2 MNS----S/L-DIN (Хвостовик с лыской)

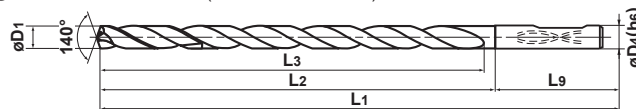

Диам. сверла D1 (мм)	Глубина сверления (l/d)	Наличие TF15	Обозначение	Размеры (мм)					Тип
				L1	L2	L3	L9	D4	
4.6	3	□	MNS0460S-DIN	66	30	24	36	6	2
	3	□	0460S-DIN-C	66	30	24	36	6	1
	5	□	0460L-DIN	74	38	36	36	6	2
	5	□	0460L-DIN-C	74	38	36	36	6	1
	8	□	0460-L8C	96	60	55	36	6	1
	10	□	0460-L10C	106	70	66	36	6	1
	12	□	0460-L12C	116	80	76	36	6	1
	15	□	0460-L15C	131	95	91	36	6	1
	20	□	0460-L20C	156	120	116	36	6	1
	25	□	0460-L25C	181	145	141	36	6	1
	30	□	0460-L30C	206	170	166	36	6	1
	5	★	0460LB	105	55	55	50	5	1
10	□	0460X10DB	118	68	65	50	5	1	
20	□	0460X20DB	168	118	115	50	5	1	
30	□	0460X30DB	218	168	165	50	5	1	
4.65	3	□	0465S-DIN	66	30	24	36	6	2
	3	□	0465S-DIN-C	66	30	24	36	6	1
	5	□	0465L-DIN	74	38	36	36	6	2
	5	●	0465L-DIN-C	74	38	36	36	6	1
4.7	3	□	0470S-DIN	66	30	24	36	6	2
	3	□	0470S-DIN-C	66	30	24	36	6	1
	5	□	0470L-DIN	74	38	36	36	6	2
	5	□	0470L-DIN-C	74	38	36	36	6	1
	8	□	0470-L8C	96	60	55	36	6	1
	10	□	0470-L10C	106	70	66	36	6	1
	12	□	0470-L12C	116	80	76	36	6	1
	15	□	0470-L15C	131	95	91	36	6	1
	20	□	0470-L20C	156	120	116	36	6	1
	25	□	0470-L25C	181	145	141	36	6	1
	30	□	0470-L30C	206	170	166	36	6	1
	5	★	0470LB	105	55	55	50	5	1
	10	□	0470X10DB	118	68	65	50	5	1
	20	□	0470X20DB	168	118	115	50	5	1
	30	□	0470X30DB	218	168	165	50	5	1

Диам. сверла D1 (мм)	Глубина сверления (l/d)	Наличие TF15	Обозначение	Размеры (мм)					Тип
				L1	L2	L3	L9	D4	
4.8	3	□	MNS0480S-DIN	66	30	28	36	6	2
	3	□	0480S-DIN-C	66	30	28	36	6	1
	5	□	0480L-DIN	82	46	44	36	6	2
	5	□	0480L-DIN-C	82	46	44	36	6	1
	8	□	0480-L8C	96	60	55	36	6	1
	10	□	0480-L10C	106	70	66	36	6	1
	12	□	0480-L12C	116	80	76	36	6	1
	15	□	0480-L15C	131	95	91	36	6	1
	20	□	0480-L20C	156	120	116	36	6	1
	25	□	0480-L25C	181	145	141	36	6	1
	30	□	0480-L30C	206	170	166	36	6	1
	5	★	0480LB	105	55	55	50	5	1
10	□	0480X10DB	118	68	65	50	5	1	
20	□	0480X20DB	168	118	115	50	5	1	
30	□	0480X30DB	218	168	165	50	5	1	
4.9	3	□	0490S-DIN	66	30	28	36	6	2
	3	□	0490S-DIN-C	66	30	28	36	6	1
	5	□	0490L-DIN	82	46	44	36	6	2
	5	□	0490L-DIN-C	82	46	44	36	6	1
	8	□	0490-L8C	96	60	55	36	6	1
	10	□	0490-L10C	106	70	66	36	6	1
	12	□	0490-L12C	116	80	76	36	6	1
	15	□	0490-L15C	131	95	91	36	6	1
	20	□	0490-L20C	156	120	116	36	6	1
	25	□	0490-L25C	181	145	141	36	6	1
	30	□	0490-L30C	206	170	166	36	6	1
	5	★	0490LB	105	55	55	50	5	1
	10	★	0490X10DB	118	68	65	50	5	1
	20	★	0490X20DB	168	118	115	50	5	1
	30	★	0490X30DB	218	168	165	50	5	1

# СВЕРЛЕНИЕ (МОНОЛИТНЫЕ ТВЕРДОСПЛАВНЫЕ СВЕРЛА)

## MNS

ТВЕРДЫЙ  
СПЛАВ

Диам. сверла D1 (мм)	Глубина сверления (l/d)	Наличие TF15	Обозначение	Размеры (мм)					Тип
				L1	L2	L3	L9	D4	
5.0	3	□	MNS0500S-DIN	66	30	28	36	6	2
	3	□	0500S-DIN-C	66	30	28	36	6	1
	5	□	0500L-DIN	82	46	44	36	6	2
	5	●	0500L-DIN-C	82	46	44	36	6	1
	8	□	0500-L8C	96	60	55	36	6	1
	10	□	0500-L10C	106	70	66	36	6	1
	12	●	0500-L12C	116	80	76	36	6	1
	15	□	0500-L15C	131	95	91	36	6	1
	20	●	0500-L20C	156	120	116	36	6	1
	25	□	0500-L25C	181	145	141	36	6	1
	30	●	0500-L30C	206	170	166	36	6	1
	5	★	0500LB	100	44	44	56	6	1
	10	★	0500X10DB	118	68	65	50	5	1
	20	★	0500X20DB	168	118	115	50	5	1
30	★	0500X30DB	218	168	165	50	5	1	
5.1	3	□	0510S-DIN	66	30	28	36	6	2
	3	□	0510S-DIN-C	66	30	28	36	6	1
	5	□	0510L-DIN	82	46	44	36	6	2
	5	●	0510L-DIN-C	82	46	44	36	6	1
	8	□	0510-L8C	102	66	62	36	6	1
	10	□	0510-L10C	113	77	73	36	6	1
	12	□	0510-L12C	124	88	84	36	6	1
	15	□	0510-L15C	140	104	100	36	6	1
	20	□	0510-L20C	168	132	128	36	6	1
	25	□	0510-L25C	195	159	155	36	6	1
	30	□	0510-L30C	223	187	183	36	6	1
	5	★	0510LB	100	44	44	56	6	1
	10	★	0510X10DB	127	75	72	52	6	1
	20	★	0510X20DB	182	130	127	52	6	1
30	★	0510X30DB	237	185	182	52	6	1	
5.2	3	□	0520S-DIN	66	30	28	36	6	2
	3	□	0520S-DIN-C	66	30	28	36	6	1
	5	□	0520L-DIN	82	46	44	36	6	2
	5	□	0520L-DIN-C	82	46	44	36	6	1
	8	□	0520-L8C	102	66	62	36	6	1
	10	□	0520-L10C	113	77	73	36	6	1
	12	□	0520-L12C	124	88	84	36	6	1
	15	□	0520-L15C	140	104	100	36	6	1
	20	□	0520-L20C	168	132	128	36	6	1
	25	□	0520-L25C	195	159	155	36	6	1
	30	□	0520-L30C	223	187	183	36	6	1
	5	★	0520LB	100	44	44	56	6	1
	10	□	0520X10DB	127	75	72	52	6	1
	20	□	0520X20DB	182	130	127	52	6	1
30	□	0520X30DB	237	185	182	52	6	1	

Диам. сверла D1 (мм)	Глубина сверления (l/d)	Наличие TF15	Обозначение	Размеры (мм)					Тип
				L1	L2	L3	L9	D4	
5.3	3	□	MNS0530S-DIN	66	30	28	36	6	2
	3	□	0530S-DIN-C	66	30	28	36	6	1
	5	□	0530L-DIN	82	46	44	36	6	2
	5	□	0530L-DIN-C	82	46	44	36	6	1
	8	□	0530-L8C	102	66	62	36	6	1
	10	□	0530-L10C	113	77	73	36	6	1
	12	□	0530-L12C	124	88	84	36	6	1
	15	□	0530-L15C	140	104	100	36	6	1
	20	□	0530-L20C	168	132	128	36	6	1
	25	□	0530-L25C	195	159	155	36	6	1
	30	□	0530-L30C	223	187	183	36	6	1
	5	★	0530LB	100	44	44	56	6	1
	10	□	0530X10DB	127	75	72	52	6	1
	20	□	0530X20DB	182	130	127	52	6	1
30	□	0530X30DB	237	185	182	52	6	1	
5.4	3	□	0540S-DIN	66	30	28	36	6	2
	3	□	0540S-DIN-C	66	30	28	36	6	1
	5	□	0540L-DIN	82	46	44	36	6	2
	5	□	0540L-DIN-C	82	46	44	36	6	1
	8	□	0540-L8C	102	66	62	36	6	1
	10	□	0540-L10C	113	77	73	36	6	1
	12	□	0540-L12C	124	88	84	36	6	1
	15	□	0540-L15C	140	104	100	36	6	1
	20	□	0540-L20C	168	132	128	36	6	1
	25	□	0540-L25C	195	159	155	36	6	1
	30	□	0540-L30C	223	187	183	36	6	1
	5	★	0540LB	100	44	44	56	6	1
	10	□	0540X10DB	127	75	72	52	6	1
	20	□	0540X20DB	182	130	127	52	6	1
30	□	0540X30DB	237	185	182	52	6	1	
5.5	3	□	0550S-DIN	66	30	28	36	6	2
	3	□	0550S-DIN-C	66	30	28	36	6	1
	5	□	0550L-DIN	82	46	44	36	6	2
	5	●	0550L-DIN-C	82	46	44	36	6	1
	8	□	0550-L8C	102	66	62	36	6	1
	10	□	0550-L10C	113	77	73	36	6	1
	12	●	0550-L12C	124	88	84	36	6	1
	15	□	0550-L15C	140	104	100	36	6	1
	20	●	0550-L20C	168	132	128	36	6	1
	25	□	0550-L25C	195	159	155	36	6	1
	30	●	0550-L30C	223	187	183	36	6	1
	5	★	0550LB	100	44	44	56	6	1
	10	★	0550X10DB	127	75	72	52	6	1
	20	★	0550X20DB	182	130	127	52	6	1
30	★	0550X30DB	237	185	182	52	6	1	
5.55	3	□	0555S-DIN	66	30	28	36	6	2
	3	□	0555S-DIN-C	66	30	28	36	6	1
	5	□	0555L-DIN	82	46	44	36	6	2
	5	●	0555L-DIN-C	82	46	44	36	6	1

(Примечание) Пожалуйста, свяжитесь с нами если Вы не нашли нужную геометрию в данном каталоге (могут быть заказаны другие диаметры и длины).

● : Есть на складе. ★ : Со склада в Японии.

□ : Нет на складе, выпускается исключительно под заказ.

L076

Заказ инструмента: <http://steelcam.org> | 8 (343) 382-52-03 | [sales@sverla-ekb.ru](mailto:sales@sverla-ekb.ru)

СВЕРЛЕНИЕ

Диам. сверла D1 (мм)	Глубина сверления (l/d)	Наличие TF15	Обозначение	Размеры (мм)					Тип
				L1	L2	L3	L9	D4	
5.6	3	□	MNS0560S-DIN	66	30	28	36	6	2
	3	□	0560S-DIN-C	66	30	28	36	6	1
	5	□	0560L-DIN	82	46	44	36	6	2
	5	□	0560L-DIN-C	82	46	44	36	6	1
	8	□	0560-L8C	107	71	67	36	6	1
	10	□	0560-L10C	119	83	79	36	6	1
	12	□	0560-L12C	131	95	91	36	6	1
	15	□	0560-L15C	149	113	109	36	6	1
	20	□	0560-L20C	179	143	139	36	6	1
	25	□	0560-L25C	209	173	169	36	6	1
	30	□	0560-L30C	239	203	199	36	6	1
	5	★	0560LB	100	48	48	52	6	1
	10	□	0560X10DB	133	81	78	52	6	1
	20	□	0560X20DB	193	141	138	52	6	1
30	□	0560X30DB	253	201	198	52	6	1	
5.7	3	□	0570S-DIN	66	30	28	36	6	2
	3	□	0570S-DIN-C	66	30	28	36	6	1
	5	□	0570L-DIN	82	46	44	36	6	2
	5	□	0570L-DIN-C	82	46	44	36	6	1
	8	□	0570-L8C	107	71	67	36	6	1
	10	□	0570-L10C	119	83	79	36	6	1
	12	□	0570-L12C	131	95	91	36	6	1
	15	□	0570-L15C	149	113	109	36	6	1
	20	□	0570-L20C	179	143	139	36	6	1
	25	□	0570-L25C	209	173	169	36	6	1
	30	□	0570-L30C	239	203	199	36	6	1
	5	★	0570LB	100	48	48	52	6	1
	10	□	0570X10DB	133	81	78	52	6	1
	20	□	0570X20DB	193	141	138	52	6	1
30	□	0570X30DB	253	201	198	52	6	1	
5.8	3	□	0580S-DIN	66	30	28	36	6	2
	3	□	0580S-DIN-C	66	30	28	36	6	1
	5	□	0580L-DIN	82	46	44	36	6	2
	5	□	0580L-DIN-C	82	46	44	36	6	1
	8	□	0580-L8C	107	71	67	36	6	1
	10	□	0580-L10C	119	83	79	36	6	1
	12	□	0580-L12C	131	95	91	36	6	1
	15	□	0580-L15C	149	113	109	36	6	1
	20	□	0580-L20C	179	143	139	36	6	1
	25	□	0580-L25C	209	173	169	36	6	1
	30	□	0580-L30C	239	203	199	36	6	1
	5	★	0580LB	100	48	48	52	6	1
	10	□	0580X10DB	133	81	78	52	6	1
	20	□	0580X20DB	193	141	138	52	6	1
30	□	0580X30DB	253	201	198	52	6	1	

Диам. сверла D1 (мм)	Глубина сверления (l/d)	Наличие TF15	Обозначение	Размеры (мм)					Тип
				L1	L2	L3	L9	D4	
5.9	3	□	MNS0590S-DIN	66	30	28	36	6	2
	3	□	0590S-DIN-C	66	30	28	36	6	1
	5	□	0590L-DIN	82	46	44	36	6	2
	5	□	0590L-DIN-C	82	46	44	36	6	1
	8	□	0590-L8C	107	71	67	36	6	1
	10	□	0590-L10C	119	83	79	36	6	1
	12	□	0590-L12C	131	95	91	36	6	1
	15	□	0590-L15C	149	113	109	36	6	1
	20	□	0590-L20C	179	143	139	36	6	1
	25	□	0590-L25C	209	173	169	36	6	1
	30	□	0590-L30C	239	203	199	36	6	1
	5	★	0590LB	100	48	48	52	6	1
	10	□	0590X10DB	133	81	78	52	6	1
	20	□	0590X20DB	193	141	138	52	6	1
30	□	0590X30DB	253	201	198	52	6	1	
6.0	3	□	0600S-DIN	66	30	28	36	6	2
	3	□	0600S-DIN-C	66	30	28	36	6	1
	5	□	0600L-DIN	82	46	44	36	6	2
	5	●	0600L-DIN-C	82	46	44	36	6	1
	8	□	0600-L8C	107	71	67	36	6	1
	10	□	0600-L10C	119	83	79	36	6	1
	12	●	0600-L12C	131	95	91	36	6	1
	15	□	0600-L15C	149	113	109	36	6	1
	20	●	0600-L20C	179	143	139	36	6	1
	25	□	0600-L25C	209	173	169	36	6	1
	30	●	0600-L30C	239	203	199	36	6	1
	5	★	0600LB	100	48	48	52	6	1
	10	★	0600X10DB	133	81	78	52	6	1
	20	★	0600X20DB	193	141	138	52	6	1
30	★	0600X30DB	253	201	198	52	6	1	
6.1	3	□	0610S-DIN	79	43	34	36	8	2
	3	□	0610S-DIN-C	79	43	34	36	8	1
	5	□	0610L-DIN	91	55	53	36	8	2
	5	□	0610L-DIN-C	91	55	53	36	8	1
	8	□	0610-L8C	113	77	73	36	8	1
	10	□	0610-L10C	126	90	86	36	8	1
	12	□	0610-L12C	139	103	99	36	8	1
	15	□	0610-L15C	158	122	118	36	8	1
	20	□	0610-L20C	191	155	151	36	8	1
	25	□	0610-L25C	223	187	183	36	8	1
	30	□	0610-L30C	256	220	216	36	8	1
	5	★	0610LB	109	52	52	57	7	1
	10	★	0610X10DB	141	88	85	53	7	1
	20	★	0610X20DB	206	153	150	53	7	1
30	★	0610X30DB	271	218	215	53	7	1	

# СВЕРЛЕНИЕ (МОНОЛИТНЫЕ ТВЕРДОСПЛАВНЫЕ СВЕРЛА)

## MNS

ТВЕРДЫЙ  
СПЛАВ

Диам. сверла D1 (мм)	Глубина сверления (l/d)	Наличие TF15	Обозначение	Размеры (мм)					Тип
				L1	L2	L3	L9	D4	
6.2	3	□	MNS0620S-DIN	79	43	34	36	8	2
	3	□	0620S-DIN-C	79	43	34	36	8	1
	5	□	0620L-DIN	91	55	53	36	8	2
	5	□	0620L-DIN-C	91	55	53	36	8	1
	8	□	0620-L8C	113	77	73	36	8	1
	10	□	0620-L10C	126	90	86	36	8	1
	12	□	0620-L12C	139	103	99	36	8	1
	15	□	0620-L15C	158	122	118	36	8	1
	20	□	0620-L20C	191	155	151	36	8	1
	25	□	0620-L25C	223	187	183	36	8	1
	30	□	0620-L30C	256	220	216	36	8	1
	5	★	0620LB	109	52	52	57	7	1
	10	□	0620X10DB	141	88	85	53	7	1
	20	□	0620X20DB	206	153	150	53	7	1
30	□	0620X30DB	271	218	215	53	7	1	
6.3	3	□	0630S-DIN	79	43	34	36	8	2
	3	□	0630S-DIN-C	79	43	34	36	8	1
	5	□	0630L-DIN	91	55	53	36	8	2
	5	□	0630L-DIN-C	91	55	53	36	8	1
	8	□	0630-L8C	113	77	73	36	8	1
	10	□	0630-L10C	126	90	86	36	8	1
	12	□	0630-L12C	139	103	99	36	8	1
	15	□	0630-L15C	158	122	118	36	8	1
	20	□	0630-L20C	191	155	151	36	8	1
	25	□	0630-L25C	223	187	183	36	8	1
	30	□	0630-L30C	256	220	216	36	8	1
	5	★	0630LB	109	52	52	57	7	1
	10	□	0630X10DB	141	88	85	53	7	1
	20	□	0630X20DB	206	153	150	53	7	1
30	□	0630X30DB	271	218	215	53	7	1	
6.4	3	□	0640S-DIN	79	43	34	36	8	2
	3	□	0640S-DIN-C	79	43	34	36	8	1
	5	□	0640L-DIN	91	55	53	36	8	2
	5	□	0640L-DIN-C	91	55	53	36	8	1
	8	□	0640-L8C	113	77	73	36	8	1
	10	□	0640-L10C	126	90	86	36	8	1
	12	□	0640-L12C	139	103	99	36	8	1
	15	□	0640-L15C	158	122	118	36	8	1
	20	□	0640-L20C	191	155	151	36	8	1
	25	□	0640-L25C	223	187	183	36	8	1
	30	□	0640-L30C	256	220	216	36	8	1
	5	★	0640LB	109	52	52	57	7	1
	10	□	0640X10DB	141	88	85	53	7	1
	20	□	0640X20DB	206	153	150	53	7	1
30	□	0640X30DB	271	218	215	53	7	1	

Диам. сверла D1 (мм)	Глубина сверления (l/d)	Наличие TF15	Обозначение	Размеры (мм)					Тип
				L1	L2	L3	L9	D4	
6.5	3	□	MNS0650S-DIN	79	43	34	36	8	2
	3	□	0650S-DIN-C	79	43	34	36	8	1
	5	□	0650L-DIN	91	55	53	36	8	2
	5	●	0650L-DIN-C	91	55	53	36	8	1
	8	□	0650-L8C	113	77	73	36	8	1
	10	□	0650-L10C	126	90	86	36	8	1
	12	●	0650-L12C	139	103	99	36	8	1
	15	□	0650-L15C	158	122	118	36	8	1
	20	●	0650-L20C	191	155	151	36	8	1
	25	□	0650-L25C	223	187	183	36	8	1
	30	●	0650-L30C	256	220	216	36	8	1
	5	★	0650LB	109	52	52	57	7	1
	10	★	0650X10DB	141	88	85	53	7	1
	20	★	0650X20DB	206	153	150	53	7	1
30	★	0650X30DB	271	218	215	53	7	1	
6.6	3	□	0660S-DIN	79	43	34	36	8	2
	3	□	0660S-DIN-C	79	43	34	36	8	1
	5	□	0660L-DIN	91	55	53	36	8	2
	5	□	0660L-DIN-C	91	55	53	36	8	1
	8	□	0660-L8C	118	82	78	36	8	1
	10	□	0660-L10C	132	96	92	36	8	1
	12	□	0660-L12C	146	110	106	36	8	1
	15	□	0660-L15C	167	131	127	36	8	1
	20	□	0660-L20C	202	166	162	36	8	1
	25	□	0660-L25C	237	201	197	36	8	1
	30	□	0660-L30C	272	236	232	36	8	1
	5	★	0660LB	109	56	56	53	7	1
	10	□	0660X10DB	147	94	91	53	7	1
	20	□	0660X20DB	217	164	161	53	7	1
30	□	0660X30DB	287	234	231	53	7	1	
6.7	3	□	0670S-DIN	79	43	34	36	8	2
	3	□	0670S-DIN-C	79	43	34	36	8	1
	5	□	0670L-DIN	91	55	53	36	8	2
	5	□	0670L-DIN-C	91	55	53	36	8	1
	8	□	0670-L8C	118	82	78	36	8	1
	10	□	0670-L10C	132	96	92	36	8	1
	12	□	0670-L12C	146	110	106	36	8	1
	15	□	0670-L15C	167	131	127	36	8	1
	20	□	0670-L20C	202	166	162	36	8	1
	25	□	0670-L25C	237	201	197	36	8	1
	30	□	0670-L30C	272	236	232	36	8	1
	5	★	0670LB	109	56	56	53	7	1
	10	★	0670X10DB	147	94	91	53	7	1
	20	★	0670X20DB	217	164	161	53	7	1
30	★	0670X30DB	287	234	231	53	7	1	

(Примечание) Пожалуйста, свяжитесь с нами если Вы не нашли нужную геометрию в данном каталоге (могут быть заказаны другие диаметры и длины).

● : Есть на складе. ★ : Со склада в Японии.

□ : Нет на складе, выпускается исключительно под заказ.

L078

Диам. сверла D1 (мм)	Глубина сверления (l/d)	Наличие TF15	Обозначение	Размеры (мм)					Тип
				L1	L2	L3	L9	D4	
6.8	3	□	MNS0680S-DIN	79	43	34	36	8	2
	3	□	0680S-DIN-C	79	43	34	36	8	1
	5	□	0680L-DIN	79	43	34	36	8	2
	5	●	0680L-DIN-C	91	55	53	36	8	1
	8	□	0680-L8C	118	82	78	36	8	1
	10	□	0680-L10C	132	96	92	36	8	1
	12	●	0680-L12C	146	110	106	36	8	1
	15	□	0680-L15C	167	131	127	36	8	1
	20	●	0680-L20C	202	166	162	36	8	1
	25	□	0680-L25C	237	201	197	36	8	1
	30	●	0680-L30C	272	236	232	36	8	1
	5	★	0680LB	109	56	56	53	7	1
	10	□	0680X10DB	147	94	91	53	7	1
	20	□	0680X20DB	217	164	161	53	7	1
30	□	0680X30DB	287	234	231	53	7	1	
6.9	3	□	0690S-DIN	79	43	34	36	8	2
	3	□	0690S-DIN-C	79	43	34	36	8	1
	5	□	0690L-DIN	91	55	53	36	8	2
	5	□	0690L-DIN-C	91	55	53	36	8	1
	8	□	0690-L8C	118	82	78	36	8	1
	10	□	0690-L10C	132	96	92	36	8	1
	12	□	0690-L12C	146	110	106	36	8	1
	15	□	0690-L15C	167	131	127	36	8	1
	20	□	0690-L20C	202	166	162	36	8	1
	25	□	0690-L25C	237	201	197	36	8	1
	30	□	0690-L30C	272	236	232	36	8	1
	5	★	0690LB	109	56	56	53	7	1
	10	□	0690X10DB	147	94	91	53	7	1
	20	□	0690X20DB	217	164	161	53	7	1
30	□	0690X30DB	287	234	231	53	7	1	
7.0	3	□	0700S-DIN	79	43	34	36	8	2
	3	□	0700S-DIN-C	79	43	34	36	8	1
	5	□	0700L-DIN	91	55	53	36	8	2
	5	●	0700L-DIN-C	91	55	53	36	8	1
	8	□	0700-L8C	118	82	78	36	8	1
	10	□	0700-L10C	132	96	92	36	8	1
	12	●	0700-L12C	146	110	106	36	8	1
	15	□	0700-L15C	167	131	127	36	8	1
	20	●	0700-L20C	202	166	162	36	8	1
	25	□	0700-L25C	237	201	197	36	8	1
	30	●	0700-L30C	272	236	232	36	8	1
	5	★	0700LB	109	56	56	53	7	1
	10	★	0700X10DB	147	94	91	53	7	1
	20	★	0700X20DB	217	164	161	53	7	1
30	★	0700X30DB	287	234	231	53	7	1	

Диам. сверла D1 (мм)	Глубина сверления (l/d)	Наличие TF15	Обозначение	Размеры (мм)					Тип
				L1	L2	L3	L9	D4	
7.1	3	□	MNS0710S-DIN	79	43	41	36	8	2
	3	□	0710S-DIN-C	79	43	41	36	8	1
	5	□	0710L-DIN	91	55	53	36	8	2
	5	□	0710L-DIN-C	91	55	53	36	8	1
	8	□	0710-L8C	124	88	84	36	8	1
	10	□	0710-L10C	139	103	99	36	8	1
	12	□	0710-L12C	154	118	114	36	8	1
	15	□	0710-L15C	176	140	136	36	8	1
	20	□	0710-L20C	214	178	174	36	8	1
	25	□	0710-L25C	251	215	211	36	8	1
	30	□	0710-L30C	289	253	249	36	8	1
	5	★	0710LB	118	64	60	54	8	1
	10	□	0710X10DB	155	101	98	54	8	1
	20	□	0710X20DB	230	176	173	54	8	1
30	□	0710X30DB	305	251	248	54	8	1	
7.2	3	□	0720S-DIN	79	43	41	36	8	2
	3	□	0720S-DIN-C	79	43	41	36	8	1
	5	□	0720L-DIN	91	55	53	36	8	2
	5	□	0720L-DIN-C	91	55	53	36	8	1
	8	□	0720-L8C	124	88	84	36	8	1
	10	□	0720-L10C	139	103	99	36	8	1
	12	□	0720-L12C	154	118	114	36	8	1
	15	□	0720-L15C	176	140	136	36	8	1
	20	□	0720-L20C	214	178	174	36	8	1
	25	□	0720-L25C	251	215	211	36	8	1
	30	□	0720-L30C	289	253	249	36	8	1
	5	★	0720LB	118	64	60	54	8	1
	10	★	0720X10DB	155	101	98	54	8	1
	20	★	0720X20DB	230	176	173	54	8	1
30	★	0720X30DB	305	251	248	54	8	1	
7.3	3	□	0730S-DIN	79	43	41	36	8	2
	3	□	0730S-DIN-C	79	43	41	36	8	1
	5	□	0730L-DIN	91	55	53	36	8	2
	5	□	0730L-DIN-C	91	55	53	36	8	1
	8	□	0730-L8C	124	88	84	36	8	1
	10	□	0730-L10C	139	103	99	36	8	1
	12	□	0730-L12C	154	118	114	36	8	1
	15	□	0730-L15C	176	140	136	36	8	1
	20	□	0730-L20C	214	178	174	36	8	1
	25	□	0730-L25C	251	215	211	36	8	1
	30	□	0730-L30C	289	253	249	36	8	1
	5	★	0730LB	118	64	60	54	8	1
	10	□	0730X10DB	155	101	98	54	8	1
	20	□	0730X20DB	230	176	173	54	8	1
30	□	0730X30DB	305	251	248	54	8	1	

# СВЕРЛЕНИЕ (МОНОЛИТНЫЕ ТВЕРДОСПЛАВНЫЕ СВЕРЛА)

## MNS

ТВЕРДЫЙ  
СПЛАВ

Диам. сверла D1 (мм)	Глубина сверления (l/d)	Наличие TF15	Обозначение	Размеры (мм)					Тип
				L1	L2	L3	L9	D4	
7.4	3	<input type="checkbox"/>	MNS0740S-DIN	79	43	41	36	8	2
	3	<input type="checkbox"/>	0740S-DIN-C	79	43	41	36	8	1
	5	<input type="checkbox"/>	0740L-DIN	91	55	53	36	8	2
	5	<input type="checkbox"/>	0740L-DIN-C	91	55	53	36	8	1
	8	<input type="checkbox"/>	0740-L8C	124	88	84	36	8	1
	10	<input type="checkbox"/>	0740-L10C	139	103	99	36	8	1
	12	<input type="checkbox"/>	0740-L12C	154	118	114	36	8	1
	15	<input type="checkbox"/>	0740-L15C	176	140	136	36	8	1
	20	<input type="checkbox"/>	0740-L20C	214	178	174	36	8	1
	25	<input type="checkbox"/>	0740-L25C	251	215	211	36	8	1
	30	<input type="checkbox"/>	0740-L30C	289	253	249	36	8	1
	5	★	0740LB	118	64	60	54	8	1
	10	<input type="checkbox"/>	0740X10DB	155	101	98	54	8	1
	20	<input type="checkbox"/>	0740X20DB	230	176	173	54	8	1
30	<input type="checkbox"/>	0740X30DB	305	251	248	54	8	1	
7.5	3	<input type="checkbox"/>	0750S-DIN	79	43	41	36	8	2
	3	<input type="checkbox"/>	0750S-DIN-C	79	43	41	36	8	1
	5	<input type="checkbox"/>	0750L-DIN	91	55	53	36	8	2
	5	●	0750L-DIN-C	91	55	53	36	8	1
	8	<input type="checkbox"/>	0750-L8C	124	88	84	36	8	1
	10	<input type="checkbox"/>	0750-L10C	139	103	99	36	8	1
	12	●	0750-L12C	154	118	114	36	8	1
	15	<input type="checkbox"/>	0750-L15C	176	140	136	36	8	1
	20	●	0750-L20C	214	178	174	36	8	1
	25	<input type="checkbox"/>	0750-L25C	251	215	211	36	8	1
	30	●	0750-L30C	289	253	249	36	8	1
	5	★	0750LB	118	64	60	54	8	1
	10	<input type="checkbox"/>	0750X10DB	155	101	98	54	8	1
	20	<input type="checkbox"/>	0750X20DB	230	176	173	54	8	1
30	<input type="checkbox"/>	0750X30DB	305	251	248	54	8	1	
7.6	3	<input type="checkbox"/>	0760S-DIN	79	43	41	36	8	2
	3	<input type="checkbox"/>	0760S-DIN-C	79	43	41	36	8	1
	5	<input type="checkbox"/>	0760L-DIN	91	55	53	36	8	2
	5	<input type="checkbox"/>	0760L-DIN-C	91	55	53	36	8	1
	8	<input type="checkbox"/>	0760-L8C	129	93	89	36	8	1
	10	<input type="checkbox"/>	0760-L10C	145	109	105	36	8	1
	12	<input type="checkbox"/>	0760-L12C	161	125	121	36	8	1
	15	<input type="checkbox"/>	0760-L15C	185	149	145	36	8	1
	20	<input type="checkbox"/>	0760-L20C	225	189	185	36	8	1
	25	<input type="checkbox"/>	0760-L25C	265	229	225	36	8	1
	30	<input type="checkbox"/>	0760-L30C	305	269	265	36	8	1
	5	★	0760LB	118	64	64	54	8	1
	10	<input type="checkbox"/>	0760X10DB	161	107	104	54	8	1
	20	<input type="checkbox"/>	0760X20DB	241	187	184	54	8	1
30	<input type="checkbox"/>	0760X30DB	321	267	264	54	8	1	

Диам. сверла D1 (мм)	Глубина сверления (l/d)	Наличие TF15	Обозначение	Размеры (мм)					Тип
				L1	L2	L3	L9	D4	
7.7	3	<input type="checkbox"/>	MNS0770S-DIN	79	43	41	36	8	2
	3	<input type="checkbox"/>	0770S-DIN-C	79	43	41	36	8	1
	5	<input type="checkbox"/>	0770L-DIN	91	55	53	36	8	2
	5	<input type="checkbox"/>	0770L-DIN-C	91	55	53	36	8	1
	8	<input type="checkbox"/>	0770-L8C	129	93	89	36	8	1
	10	<input type="checkbox"/>	0770-L10C	145	109	105	36	8	1
	12	<input type="checkbox"/>	0770-L12C	161	125	121	36	8	1
	15	<input type="checkbox"/>	0770-L15C	185	149	145	36	8	1
	20	<input type="checkbox"/>	0770-L20C	225	189	185	36	8	1
	25	<input type="checkbox"/>	0770-L25C	265	229	225	36	8	1
	30	<input type="checkbox"/>	0770-L30C	305	269	265	36	8	1
	5	★	0770LB	118	64	64	54	8	1
	10	<input type="checkbox"/>	0770X10DB	161	107	104	54	8	1
	20	<input type="checkbox"/>	0770X20DB	241	187	184	54	8	1
30	<input type="checkbox"/>	0770X30DB	321	267	264	54	8	1	
7.8	3	<input type="checkbox"/>	0780S-DIN	79	43	41	36	8	2
	3	<input type="checkbox"/>	0780S-DIN-C	79	43	41	36	8	1
	5	<input type="checkbox"/>	0780L-DIN	91	55	53	36	8	2
	5	<input type="checkbox"/>	0780L-DIN-C	91	55	53	36	8	1
	8	<input type="checkbox"/>	0780-L8C	129	93	89	36	8	1
	10	<input type="checkbox"/>	0780-L10C	145	109	105	36	8	1
	12	<input type="checkbox"/>	0780-L12C	161	125	121	36	8	1
	15	<input type="checkbox"/>	0780-L15C	185	149	145	36	8	1
	20	<input type="checkbox"/>	0780-L20C	225	189	185	36	8	1
	25	<input type="checkbox"/>	0780-L25C	265	229	225	36	8	1
	30	<input type="checkbox"/>	0780-L30C	305	269	265	36	8	1
	5	★	0780LB	118	64	64	54	8	1
	10	★	0780X10DB	161	107	104	54	8	1
	20	★	0780X20DB	241	187	184	54	8	1
30	★	0780X30DB	321	267	264	54	8	1	
7.9	3	<input type="checkbox"/>	0790S-DIN	79	43	41	36	8	2
	3	<input type="checkbox"/>	0790S-DIN-C	79	43	41	36	8	1
	5	<input type="checkbox"/>	0790L-DIN	91	55	53	36	8	2
	5	<input type="checkbox"/>	0790L-DIN-C	91	55	53	36	8	1
	8	<input type="checkbox"/>	0790-L8C	129	93	89	36	8	1
	10	<input type="checkbox"/>	0790-L10C	145	109	105	36	8	1
	12	<input type="checkbox"/>	0790-L12C	161	125	121	36	8	1
	15	<input type="checkbox"/>	0790-L15C	185	149	145	36	8	1
	20	<input type="checkbox"/>	0790-L20C	225	189	185	36	8	1
	25	<input type="checkbox"/>	0790-L25C	265	229	225	36	8	1
	30	<input type="checkbox"/>	0790-L30C	305	269	265	36	8	1
	5	★	0790LB	118	64	64	54	8	1
	10	<input type="checkbox"/>	0790X10DB	161	107	104	54	8	1
	20	<input type="checkbox"/>	0790X20DB	241	187	184	54	8	1
30	<input type="checkbox"/>	0790X30DB	321	267	264	54	8	1	

(Примечание) Пожалуйста, свяжитесь с нами если Вы не нашли нужную геометрию в данном каталоге (могут быть заказаны другие диаметры и длины).

● : Есть на складе. ★ : Со склада в Японии.

□ : Нет на складе, выпускается исключительно под заказ.

L080

Заказ инструмента: <http://steelcam.org> | 8 (343) 382-52-03 | [sales@sverla-ekb.ru](mailto:sales@sverla-ekb.ru)

СВЕРЛЕНИЕ

Диам. сверла D1 (мм)	Глубина сверления (l/d)	Наличие TF15	Обозначение	Размеры (мм)					Тип
				L1	L2	L3	L9	D4	
8.0	3	□	MNS0800S-DIN	79	43	41	36	8	2
	3	□	0800S-DIN-C	79	43	41	36	8	1
	5	□	0800L-DIN	91	55	53	36	8	2
	5	●	0800L-DIN-C	91	55	53	36	8	1
	8	□	0800-L8C	129	93	89	36	8	1
	10	□	0800-L10C	145	109	105	36	8	1
	12	●	0800-L12C	161	125	121	36	8	1
	15	□	0800-L15C	185	149	145	36	8	1
	20	●	0800-L20C	225	189	185	36	8	1
	25	□	0800-L25C	265	229	225	36	8	1
	30	●	0800-L30C	305	269	265	36	8	1
	5	★	0800LB	118	64	64	54	8	1
	10	★	0800X10DB	161	107	104	54	8	1
	20	★	0800X20DB	241	187	184	54	8	1
30	★	0800X30DB	321	267	264	54	8	1	
8.1	3	□	0810S-DIN	88	48	46	40	10	2
	3	□	0810S-DIN-C	88	48	46	40	10	1
	5	□	0810L-DIN	102	62	60	40	10	2
	5	□	0810L-DIN-C	102	62	60	40	10	1
	8	□	0810-L8C	139	99	95	40	10	1
	10	□	0810-L10C	156	116	112	40	10	1
	12	□	0810-L12C	173	133	129	40	10	1
	15	□	0810-L15C	198	158	154	40	10	1
	20	□	0810-L20C	241	201	197	40	10	1
	25	□	0810-L25C	283	243	239	40	10	1
	30	□	0810-L30C	326	286	282	40	10	1
	5	★	0810LB	127	72	68	55	9	1
	10	□	0810X10DB	169	114	111	55	9	1
	20	□	0810X20DB	254	199	196	55	9	1
30	□	0810X30DB	339	284	281	55	9	1	
8.2	3	□	0820S-DIN	88	48	46	40	10	2
	3	□	0820S-DIN-C	88	48	46	40	10	1
	5	□	0820L-DIN	102	62	60	40	10	2
	5	□	0820L-DIN-C	102	62	60	40	10	1
	8	□	0820-L8C	139	99	95	40	10	1
	10	□	0820-L10C	156	116	112	40	10	1
	12	□	0820-L12C	173	133	129	40	10	1
	15	□	0820-L15C	198	158	154	40	10	1
	20	□	0820-L20C	241	201	197	40	10	1
	25	□	0820-L25C	283	243	239	40	10	1
	30	□	0820-L30C	326	286	282	40	10	1
	5	★	0820LB	127	72	68	55	9	1
	10	□	0820X10DB	169	114	111	55	9	1
	20	□	0820X20DB	254	199	196	55	9	1
30	□	0820X30DB	339	284	281	55	9	1	

Диам. сверла D1 (мм)	Глубина сверления (l/d)	Наличие TF15	Обозначение	Размеры (мм)					Тип
				L1	L2	L3	L9	D4	
8.3	3	□	MNS0830S-DIN	88	48	46	40	10	2
	3	□	0830S-DIN-C	88	48	46	40	10	1
	5	□	0830L-DIN	102	62	60	40	10	2
	5	□	0830L-DIN-C	102	62	60	40	10	1
	8	□	0830-L8C	139	99	95	40	10	1
	10	□	0830-L10C	156	116	112	40	10	1
	12	□	0830-L12C	173	133	129	40	10	1
	15	□	0830-L15C	198	158	154	40	10	1
	20	□	0830-L20C	241	201	197	40	10	1
	25	□	0830-L25C	283	243	239	40	10	1
	30	□	0830-L30C	326	286	282	40	10	1
	5	★	0830LB	127	72	68	55	9	1
	10	□	0830X10DB	169	114	111	55	9	1
	20	□	0830X20DB	254	199	196	55	9	1
30	□	0830X30DB	339	284	281	55	9	1	
8.4	3	□	0840S-DIN	88	48	46	40	10	2
	3	□	0840S-DIN-C	88	48	46	40	10	1
	5	□	0840L-DIN	102	62	60	40	10	2
	5	□	0840L-DIN-C	102	62	60	40	10	1
	8	□	0840-L8C	139	99	95	40	10	1
	10	□	0840-L10C	156	116	112	40	10	1
	12	□	0840-L12C	173	133	129	40	10	1
	15	□	0840-L15C	198	158	154	40	10	1
	20	□	0840-L20C	241	201	197	40	10	1
	25	□	0840-L25C	283	243	239	40	10	1
	30	□	0840-L30C	326	286	282	40	10	1
	5	★	0840LB	127	72	68	55	9	1
	10	□	0840X10DB	169	114	111	55	9	1
	20	□	0840X20DB	254	199	196	55	9	1
30	□	0840X30DB	339	284	281	55	9	1	
8.5	3	□	0850S-DIN	88	48	46	40	10	2
	3	□	0850S-DIN-C	88	48	46	40	10	1
	5	□	0850L-DIN	102	62	60	40	10	2
	5	●	0850L-DIN-C	102	62	60	40	10	1
	8	□	0850-L8C	139	99	95	40	10	1
	10	□	0850-L10C	156	116	112	40	10	1
	12	●	0850-L12C	173	133	129	40	10	1
	15	□	0850-L15C	198	158	154	40	10	1
	20	●	0850-L20C	241	201	197	40	10	1
	25	□	0850-L25C	283	243	239	40	10	1
	30	●	0850-L30C	326	286	282	40	10	1
	5	★	0850LB	127	72	68	55	9	1
	10	□	0850X10DB	169	114	111	55	9	1
	20	□	0850X20DB	254	199	196	55	9	1
30	□	0850X30DB	339	284	281	55	9	1	

# СВЕРЛЕНИЕ (МОНОЛИТНЫЕ ТВЕРДОСПЛАВНЫЕ СВЕРЛА)

## MNS

ТВЕРДЫЙ  
СПЛАВ

Диам. сверла D1 (мм)	Глубина сверления (l/d)	Наличие TF15	Обозначение	Размеры (мм)					Тип
				L1	L2	L3	L9	D4	
8.6	3	<input type="checkbox"/>	MNS0860S-DIN	88	48	46	40	10	2
	3	<input type="checkbox"/>	0860S-DIN-C	88	48	46	40	10	1
	5	<input type="checkbox"/>	0860L-DIN	102	62	60	40	10	2
	5	<input type="checkbox"/>	0860L-DIN-C	102	62	60	40	10	1
	8	<input type="checkbox"/>	0860-L8C	144	104	100	40	10	1
	10	<input type="checkbox"/>	0860-L10C	162	122	118	40	10	1
	12	<input type="checkbox"/>	0860-L12C	180	140	136	40	10	1
	15	<input type="checkbox"/>	0860-L15C	207	167	163	40	10	1
	20	<input type="checkbox"/>	0860-L20C	252	212	208	40	10	1
	25	<input type="checkbox"/>	0860-L25C	297	257	253	40	10	1
	30	<input type="checkbox"/>	0860-L30C	342	302	298	40	10	1
	5	★	0860LB	127	72	72	55	9	1
	10	<input type="checkbox"/>	0860X10DB	175	120	117	55	9	1
	20	<input type="checkbox"/>	0860X20DB	265	210	207	55	9	1
30	<input type="checkbox"/>	0860X30DB	355	300	297	55	9	1	
8.7	3	<input type="checkbox"/>	0870S-DIN	88	48	46	40	10	2
	3	<input type="checkbox"/>	0870S-DIN-C	88	48	46	40	10	1
	5	<input type="checkbox"/>	0870L-DIN	102	62	60	40	10	2
	5	<input type="checkbox"/>	0870L-DIN-C	102	62	60	40	10	1
	8	<input type="checkbox"/>	0870-L8C	144	104	100	40	10	1
	10	<input type="checkbox"/>	0870-L10C	162	122	118	40	10	1
	12	<input type="checkbox"/>	0870-L12C	180	140	136	40	10	1
	15	<input type="checkbox"/>	0870-L15C	207	167	163	40	10	1
	20	<input type="checkbox"/>	0870-L20C	252	212	208	40	10	1
	25	<input type="checkbox"/>	0870-L25C	297	257	253	40	10	1
	30	<input type="checkbox"/>	0870-L30C	342	302	298	40	10	1
	5	★	0870LB	127	72	72	55	9	1
	10	<input type="checkbox"/>	0870X10DB	175	120	117	55	9	1
	20	<input type="checkbox"/>	0870X20DB	265	210	207	55	9	1
30	<input type="checkbox"/>	0870X30DB	355	300	297	55	9	1	
8.8	3	<input type="checkbox"/>	0880S-DIN	88	48	46	40	10	2
	3	<input type="checkbox"/>	0880S-DIN-C	88	48	46	40	10	1
	5	<input type="checkbox"/>	0880L-DIN	102	62	60	40	10	2
	5	<input type="checkbox"/>	0880L-DIN-C	102	62	60	40	10	1
	8	<input type="checkbox"/>	0880-L8C	144	104	100	40	10	1
	10	<input type="checkbox"/>	0880-L10C	162	122	118	40	10	1
	12	<input type="checkbox"/>	0880-L12C	180	140	136	40	10	1
	15	<input type="checkbox"/>	0880-L15C	207	167	163	40	10	1
	20	<input type="checkbox"/>	0880-L20C	252	212	208	40	10	1
	25	<input type="checkbox"/>	0880-L25C	297	257	253	40	10	1
	30	<input type="checkbox"/>	0880-L30C	342	302	298	40	10	1
	5	★	0880LB	127	72	72	55	9	1
	10	<input type="checkbox"/>	0880X10DB	175	120	117	55	9	1
	20	<input type="checkbox"/>	0880X20DB	265	210	207	55	9	1
30	<input type="checkbox"/>	0880X30DB	355	300	297	55	9	1	

Диам. сверла D1 (мм)	Глубина сверления (l/d)	Наличие TF15	Обозначение	Размеры (мм)					Тип
				L1	L2	L3	L9	D4	
8.9	3	<input type="checkbox"/>	MNS0890S-DIN	88	48	46	40	10	2
	3	<input type="checkbox"/>	0890S-DIN-C	88	48	46	40	10	1
	5	<input type="checkbox"/>	0890L-DIN	102	62	60	40	10	2
	5	<input type="checkbox"/>	0890L-DIN-C	102	62	60	40	10	1
	8	<input type="checkbox"/>	0890-L8C	144	104	100	40	10	1
	10	<input type="checkbox"/>	0890-L10C	162	122	118	40	10	1
	12	<input type="checkbox"/>	0890-L12C	180	140	136	40	10	1
	15	<input type="checkbox"/>	0890-L15C	207	167	163	40	10	1
	20	<input type="checkbox"/>	0890-L20C	252	212	208	40	10	1
	25	<input type="checkbox"/>	0890-L25C	297	257	253	40	10	1
	30	<input type="checkbox"/>	0890-L30C	342	302	298	40	10	1
	5	★	0890LB	127	72	72	55	9	1
	10	<input type="checkbox"/>	0890X10DB	175	120	117	55	9	1
	20	<input type="checkbox"/>	0890X20DB	265	210	207	55	9	1
30	<input type="checkbox"/>	0890X30DB	355	300	297	55	9	1	
9.0	3	<input type="checkbox"/>	0900S-DIN	88	48	46	40	10	2
	3	<input type="checkbox"/>	0900S-DIN-C	88	48	46	40	10	1
	5	<input type="checkbox"/>	0900L-DIN	102	62	60	40	10	2
	5	●	0900L-DIN-C	102	62	60	40	10	1
	8	<input type="checkbox"/>	0900-L8C	144	104	100	40	10	1
	10	<input type="checkbox"/>	0900-L10C	162	122	118	40	10	1
	12	●	0900-L12C	180	140	136	40	10	1
	15	<input type="checkbox"/>	0900-L15C	207	167	163	40	10	1
	20	●	0900-L20C	252	212	208	40	10	1
	25	<input type="checkbox"/>	0900-L25C	297	257	253	40	10	1
	30	●	0900-L30C	342	302	298	40	10	1
	5	★	0900LB	127	72	72	55	9	1
	10	★	0900X10DB	175	120	117	55	9	1
	20	★	0900X20DB	265	210	207	55	9	1
30	★	0900X30DB	355	300	297	55	9	1	
9.1	3	<input type="checkbox"/>	0910S-DIN	89	49	47	40	10	2
	3	<input type="checkbox"/>	0910S-DIN-C	89	49	47	40	10	1
	5	<input type="checkbox"/>	0910L-DIN	103	63	62	40	10	2
	5	<input type="checkbox"/>	0910L-DIN-C	103	63	62	40	10	1
	8	<input type="checkbox"/>	0910-L8C	151	111	107	40	10	1
	10	<input type="checkbox"/>	0910-L10C	170	130	126	40	10	1
	12	<input type="checkbox"/>	0910-L12C	189	149	145	40	10	1
	15	<input type="checkbox"/>	0910-L15C	217	177	173	40	10	1
	20	<input type="checkbox"/>	0910-L20C	265	225	221	40	10	1
	25	<input type="checkbox"/>	0910-L25C	312	272	268	40	10	1
	30	<input type="checkbox"/>	0910-L30C	360	320	316	40	10	1
	5	★	0910LB	136	80	76	56	10	1
	10	<input type="checkbox"/>	0910X10DB	182	127	124	55	10	1
	20	<input type="checkbox"/>	0910X20DB	277	222	219	55	10	1
30	<input type="checkbox"/>	0910X30DB	372	317	314	55	10	1	

(Примечание) Пожалуйста, свяжитесь с нами если Вы не нашли нужную геометрию в данном каталоге (могут быть заказаны другие диаметры и длины).

● : Есть на складе. ★ : Со склада в Японии.

□ : Нет на складе, выпускается исключительно под заказ.

L082

Заказ инструмента: <http://steelcam.org> | 8 (343) 382-52-03 | [sales@sverla-ekb.ru](mailto:sales@sverla-ekb.ru)

СВЕРЛЕНИЕ

Диам. сверла D1 (мм)	Глубина сверления (l/d)	Наличие TF15	Обозначение	Размеры (мм)					Тип
				L1	L2	L3	L9	D4	
9.2	3	□	MNS0920S-DIN	89	49	47	40	10	2
	3	□	0920S-DIN-C	89	49	47	40	10	1
	5	□	0920L-DIN	103	63	62	40	10	2
	5	□	0920L-DIN-C	103	63	62	40	10	1
	8	□	0920-L8C	151	111	107	40	10	1
	10	□	0920-L10C	170	130	126	40	10	1
	12	□	0920-L12C	189	149	145	40	10	1
	15	□	0920-L15C	217	177	173	40	10	1
	20	□	0920-L20C	265	225	221	40	10	1
	25	□	0920-L25C	312	272	268	40	10	1
	30	□	0920-L30C	360	320	316	40	10	1
	5	★	0920LB	136	80	76	56	10	1
	10	□	0920X10DB	182	127	124	55	10	1
	20	□	0920X20DB	277	222	219	55	10	1
30	□	0920X30DB	372	317	314	55	10	1	
9.3	3	□	0930S-DIN	89	49	47	40	10	2
	3	□	0930S-DIN-C	89	49	47	40	10	1
	5	□	0930L-DIN	103	63	62	40	10	2
	5	□	0930L-DIN-C	103	63	62	40	10	1
	8	□	0930-L8C	151	111	107	40	10	1
	10	□	0930-L10C	170	130	126	40	10	1
	12	□	0930-L12C	189	149	145	40	10	1
	15	□	0930-L15C	217	177	173	40	10	1
	20	□	0930-L20C	265	225	221	40	10	1
	25	□	0930-L25C	312	272	268	40	10	1
	30	□	0930-L30C	360	320	316	40	10	1
	5	★	0930LB	136	80	76	56	10	1
	10	□	0930X10DB	182	127	124	55	10	1
	20	□	0930X20DB	277	222	219	55	10	1
30	□	0930X30DB	372	317	314	55	10	1	
9.4	3	□	0940S-DIN	89	49	47	40	10	2
	3	□	0940S-DIN-C	89	49	47	40	10	1
	5	□	0940L-DIN	103	63	62	40	10	2
	5	□	0940L-DIN-C	103	63	62	40	10	1
	8	□	0940-L8C	151	111	107	40	10	1
	10	□	0940-L10C	170	130	126	40	10	1
	12	□	0940-L12C	189	149	145	40	10	1
	15	□	0940-L15C	217	177	173	40	10	1
	20	□	0940-L20C	265	225	221	40	10	1
	25	□	0940-L25C	312	272	268	40	10	1
	30	□	0940-L30C	360	320	316	40	10	1
	5	★	0940LB	136	80	76	56	10	1
	10	□	0940X10DB	182	127	124	55	10	1
	20	□	0940X20DB	277	222	219	55	10	1
30	□	0940X30DB	372	317	314	55	10	1	

Диам. сверла D1 (мм)	Глубина сверления (l/d)	Наличие TF15	Обозначение	Размеры (мм)					Тип
				L1	L2	L3	L9	D4	
9.5	3	□	MNS0950S-DIN	89	49	47	40	10	2
	3	□	0950S-DIN-C	89	49	47	40	10	1
	5	□	0950L-DIN	103	63	62	40	10	2
	5	●	0950L-DIN-C	103	63	62	40	10	1
	8	□	0950-L8C	151	111	107	40	10	1
	10	□	0950-L10C	170	130	126	40	10	1
	12	●	0950-L12C	189	149	145	40	10	1
	15	□	0950-L15C	217	177	173	40	10	1
	20	●	0950-L20C	265	225	221	40	10	1
	25	□	0950-L25C	312	272	268	40	10	1
	30	●	0950-L30C	360	320	316	40	10	1
	5	★	0950LB	136	80	76	56	10	1
	10	□	0950X10DB	182	127	124	55	10	1
	20	□	0950X20DB	277	222	219	55	10	1
30	□	0950X30DB	372	317	314	55	10	1	
9.6	3	□	0960S-DIN	89	49	47	40	10	2
	3	□	0960S-DIN-C	89	49	47	40	10	1
	5	□	0960L-DIN	103	63	62	40	10	2
	5	□	0960L-DIN-C	103	63	62	40	10	1
	8	□	0960-L8C	156	116	112	40	10	1
	10	□	0960-L10C	176	136	132	40	10	1
	12	□	0960-L12C	196	156	152	40	10	1
	15	□	0960-L15C	226	186	182	40	10	1
	20	□	0960-L20C	276	236	232	40	10	1
	25	□	0960-L25C	326	286	282	40	10	1
	30	□	0960-L30C	376	336	332	40	10	1
	5	★	0960LB	136	80	80	56	10	1
	10	□	0960X10DB	188	133	130	55	10	1
	20	□	0960X20DB	288	233	230	55	10	1
30	□	0960X30DB	388	333	330	55	10	1	
9.7	3	□	0970S-DIN	89	49	47	40	10	2
	3	□	0970S-DIN-C	89	49	47	40	10	1
	5	□	0970L-DIN	103	63	62	40	10	2
	5	□	0970L-DIN-C	103	63	62	40	10	1
	8	□	0970-L8C	156	116	112	40	10	1
	10	□	0970-L10C	176	136	132	40	10	1
	12	□	0970-L12C	196	156	152	40	10	1
	15	□	0970-L15C	226	186	182	40	10	1
	20	□	0970-L20C	276	236	232	40	10	1
	25	□	0970-L25C	326	286	282	40	10	1
	30	□	0970-L30C	376	336	332	40	10	1
	5	★	0970LB	136	80	80	56	10	1
	10	□	0970X10DB	188	133	130	55	10	1
	20	□	0970X20DB	288	233	230	55	10	1
30	□	0970X30DB	388	333	330	55	10	1	

# СВЕРЛЕНИЕ (МОНОЛИТНЫЕ ТВЕРДОСПЛАВНЫЕ СВЕРЛА)

## MNS

ТВЕРДЫЙ  
СПЛАВ

Диам. сверла D1 (мм)	Глубина сверления (l/d)	Наличие TF15	Обозначение	Размеры (мм)					Тип
				L1	L2	L3	L9	D4	
9.8	3	□	MNS0980S-DIN	89	49	47	40	10	2
	3	□	0980S-DIN-C	89	49	47	40	10	1
	5	□	0980L-DIN	103	63	62	40	10	2
	5	□	0980L-DIN-C	103	63	62	40	10	1
	8	□	0980-L8C	156	116	112	40	10	1
	10	□	0980-L10C	176	136	132	40	10	1
	12	□	0980-L12C	196	156	152	40	10	1
	15	□	0980-L15C	226	186	182	40	10	1
	20	□	0980-L20C	276	236	232	40	10	1
	25	□	0980-L25C	326	286	282	40	10	1
	30	□	0980-L30C	376	336	332	40	10	1
	5	★	0980LB	136	80	80	56	10	1
	10	★	0980X10DB	188	133	130	55	10	1
	20	★	0980X20DB	288	233	230	55	10	1
30	★	0980X30DB	388	333	330	55	10	1	
9.9	3	□	0990S-DIN	89	49	47	40	10	2
	3	□	0990S-DIN-C	89	49	47	40	10	1
	5	□	0990L-DIN	103	63	62	40	10	2
	5	□	0990L-DIN-C	103	63	62	40	10	1
	8	□	0990-L8C	156	116	112	40	10	1
	10	□	0990-L10C	176	136	132	40	10	1
	12	□	0990-L12C	196	156	152	40	10	1
	15	□	0990-L15C	226	186	182	40	10	1
	20	□	0990-L20C	276	236	232	40	10	1
	25	□	0990-L25C	326	286	282	40	10	1
	30	□	0990-L30C	376	336	332	40	10	1
	5	★	0990LB	136	80	80	56	10	1
	10	□	0990X10DB	188	133	130	55	10	1
	20	□	0990X20DB	288	233	230	55	10	1
30	□	0990X30DB	388	333	330	55	10	1	
10.0	3	□	1000S-DIN	89	49	47	40	10	2
	3	□	1000S-DIN-C	89	49	47	40	10	1
	5	□	1000L-DIN	103	63	62	40	10	2
	5	●	1000L-DIN-C	103	63	62	40	10	1
	8	□	1000-L8C	156	116	112	40	10	1
	10	□	1000-L10C	176	136	132	40	10	1
	12	●	1000-L12C	196	156	152	40	10	1
	15	□	1000-L15C	226	186	182	40	10	1
	20	●	1000-L20C	276	236	232	40	10	1
	25	□	1000-L25C	326	286	282	40	10	1
	30	●	1000-L30C	376	336	332	40	10	1
	5	★	1000LB	136	80	80	56	10	1
	10	★	1000X10DB	188	133	130	55	10	1
	20	★	1000X20DB	288	233	230	55	10	1
30	★	1000X30DB	388	333	330	55	10	1	

Диам. сверла D1 (мм)	Глубина сверления (l/d)	Наличие TF15	Обозначение	Размеры (мм)					Тип
				L1	L2	L3	L9	D4	
10.1	3	□	MNS1010S-DIN	102	57	55	45	12	2
	3	□	1010S-DIN-C	102	57	55	45	12	1
	5	□	1010L-DIN	118	73	71	45	12	2
	5	□	1010L-DIN-C	118	73	71	45	12	1
	8	□	1010-L8C	167	122	118	45	12	1
	10	□	1010-L10C	188	143	139	45	12	1
	12	□	1010-L12C	209	164	160	45	12	1
	15	□	1010-L15C	240	195	191	45	12	1
	20	□	1010-L20C	293	248	244	45	12	1
	25	□	1010-L25C	345	300	296	45	12	1
	5	★	1010LB	149	88	84	61	11	1
	10	□	1010X10DB	201	140	137	61	11	1
	20	□	1010X20DB	306	245	242	61	11	1
	10.2	3	□	1020S-DIN	102	57	55	45	12
3		□	1020S-DIN-C	102	57	55	45	12	1
5		□	1020L-DIN	118	73	71	45	12	2
5		□	1020L-DIN-C	118	73	71	45	12	1
8		□	1020-L8C	167	122	118	45	12	1
10		□	1020-L10C	188	143	139	45	12	1
12		□	1020-L12C	209	164	160	45	12	1
15		□	1020-L15C	240	195	191	45	12	1
20		□	1020-L20C	293	248	244	45	12	1
25		□	1020-L25C	345	300	296	45	12	1
5		★	1020LB	149	88	84	61	11	1
10		□	1020X10DB	201	140	137	61	11	1
20		□	1020X20DB	306	245	242	61	11	1
10.3		3	□	1030S-DIN	102	57	55	45	12
	3	□	1030S-DIN-C	102	57	55	45	12	1
	5	□	1030L-DIN	118	73	71	45	12	2
	5	□	1030L-DIN-C	118	73	71	45	12	1
	8	□	1030-L8C	167	122	118	45	12	1
	10	□	1030-L10C	188	143	139	45	12	1
	12	□	1030-L12C	209	164	160	45	12	1
	15	□	1030-L15C	240	195	191	45	12	1
	20	□	1030-L20C	293	248	244	45	12	1
	25	□	1030-L25C	345	300	296	45	12	1
	5	★	1030LB	149	88	84	61	11	1
	10	□	1030X10DB	201	140	137	61	11	1
	20	□	1030X20DB	306	245	242	61	11	1

(Примечание) Пожалуйста, свяжитесь с нами если Вы не нашли нужную геометрию в данном каталоге (могут быть заказаны другие диаметры и длины).

● : Есть на складе. ★ : Со склада в Японии.

□ : Нет на складе, выпускается исключительно под заказ.

L084

Диам. сверла D1 (мм)	Глубина сверления (l/d)	Наличие TF15	Обозначение	Размеры (мм)					Тип	
				L1	L2	L3	L9	D4		
10.4	3	□	MNS1040S-DIN	102	57	55	45	12	2	
	3	□	1040S-DIN-C	102	57	55	45	12	1	
	5	□	1040L-DIN	118	73	71	45	12	2	
	5	□	1040L-DIN-C	118	73	71	45	12	1	
	8	□	1040-L8C	167	122	118	45	12	1	
	10	□	1040-L10C	188	143	139	45	12	1	
	12	□	1040-L12C	209	164	160	45	12	1	
	15	□	1040-L15C	240	195	191	45	12	1	
	20	□	1040-L20C	293	248	244	45	12	1	
	25	□	1040-L25C	345	300	296	45	12	1	
	5	★	1040LB	149	88	84	61	11	1	
	10	□	1040X10DB	201	140	137	61	11	1	
	20	□	1040X20DB	306	245	242	61	11	1	
	10.5	3	□	1050S-DIN	102	57	55	45	12	2
3		□	1050S-DIN-C	102	57	55	45	12	1	
5		□	1050L-DIN	118	73	71	45	12	2	
5		●	1050L-DIN-C	118	73	71	45	12	1	
8		□	1050-L8C	167	122	118	45	12	1	
10		□	1050-L10C	188	143	139	45	12	1	
12		●	1050-L12C	209	164	160	45	12	1	
15		□	1050-L15C	240	195	191	45	12	1	
20		●	1050-L20C	293	248	244	45	12	1	
25		□	1050-L25C	345	300	296	45	12	1	
5		★	1050LB	149	88	84	61	11	1	
10		★	1050X10DB	201	140	137	61	11	1	
20		★	1050X20DB	306	245	242	61	11	1	
10.6		3	□	1060S-DIN	102	57	55	45	12	2
	3	□	1060S-DIN-C	102	57	55	45	12	1	
	5	□	1060L-DIN	118	73	71	45	12	2	
	5	□	1060L-DIN-C	118	73	71	45	12	1	
	8	□	1060-L8C	172	127	123	45	12	1	
	10	□	1060-L10C	194	149	145	45	12	1	
	12	□	1060-L12C	216	171	167	45	12	1	
	15	□	1060-L15C	249	204	200	45	12	1	
	20	□	1060-L20C	304	259	255	45	12	1	
	25	□	1060-L25C	359	314	310	45	12	1	
	5	★	1060LB	149	88	88	61	11	1	
	10	□	1060X10DB	207	146	143	61	11	1	
	20	□	1060X20DB	317	256	253	61	11	1	
	10.7	3	□	1070S-DIN	102	57	55	45	12	2
3		□	1070S-DIN-C	102	57	55	45	12	1	
5		□	1070L-DIN	118	73	71	45	12	2	
5		□	1070L-DIN-C	118	73	71	45	12	1	
8		□	1070-L8C	172	127	123	45	12	1	
10		□	1070-L10C	194	149	145	45	12	1	
12		□	1070-L12C	216	171	167	45	12	1	
10.8		3	□	1080S-DIN	102	57	55	45	12	2
		3	□	1080S-DIN-C	102	57	55	45	12	1
		5	□	1080L-DIN	118	73	71	45	12	2
		5	□	1080L-DIN-C	118	73	71	45	12	1
		8	□	1080-L8C	172	127	123	45	12	1
	10	□	1080-L10C	194	149	145	45	12	1	
	12	□	1080-L12C	216	171	167	45	12	1	
	15	□	1080-L15C	249	204	200	45	12	1	
	20	□	1080-L20C	304	259	255	45	12	1	
	25	□	1080-L25C	359	314	310	45	12	1	
	5	★	1080LB	149	88	88	61	11	1	
	10	□	1080X10DB	207	146	143	61	11	1	
	20	□	1080X20DB	317	256	253	61	11	1	
	10.9	3	□	1090S-DIN	102	57	55	45	12	2
3		□	1090S-DIN-C	102	57	55	45	12	1	
5		□	1090L-DIN	118	73	71	45	12	2	
5		□	1090L-DIN-C	118	73	71	45	12	1	
8		□	1090-L8C	172	127	123	45	12	1	
10		□	1090-L10C	194	149	145	45	12	1	
12		□	1090-L12C	216	171	167	45	12	1	
15		□	1090-L15C	249	204	200	45	12	1	
20		□	1090-L20C	304	259	255	45	12	1	
25		□	1090-L25C	359	314	310	45	12	1	
5		★	1090LB	149	88	88	61	11	1	
10		□	1090X10DB	207	146	143	61	11	1	
20		□	1090X20DB	317	256	253	61	11	1	
11.0		3	□	1100S-DIN	102	57	55	45	12	2
	3	□	1100S-DIN-C	102	57	55	45	12	1	
	5	□	1100L-DIN	118	73	71	45	12	2	
	5	●	1100L-DIN-C	118	73	71	45	12	1	
	8	□	1100-L8C	172	127	123	45	12	1	
	10	□	1100-L10C	194	149	145	45	12	1	
	12	●	1100-L12C	216	171	167	45	12	1	
	15	□	1100-L15C	249	204	200	45	12	1	
	20	●	1100-L20C	304	259	255	45	12	1	
	25	□	1100-L25C	359	314	310	45	12	1	
	5	★	1100LB	149	88	88	61	11	1	
	10	★	1100X10DB	207	146	143	61	11	1	
	20	★	1100X20DB	317	256	253	61	11	1	

Диам. сверла D1 (мм)	Глубина сверления (l/d)	Наличие TF15	Обозначение	Размеры (мм)					Тип
				L1	L2	L3	L9	D4	
10.7	15	□	MNS1070-L15C	249	204	200	45	12	1
	20	□	1070-L20C	304	259	255	45	12	1
	25	□	1070-L25C	359	314	310	45	12	1
	5	★	1070LB	149	88	88	61	11	1
	10	□	1070X10DB	207	146	143	61	11	1
	20	□	1070X20DB	317	256	253	61	11	1
	10.8	3	□	1080S-DIN	102	57	55	45	12
3		□	1080S-DIN-C	102	57	55	45	12	1
5		□	1080L-DIN	118	73	71	45	12	2
5		□	1080L-DIN-C	118	73	71	45	12	1
8		□	1080-L8C	172	127	123	45	12	1
10		□	1080-L10C	194	149	145	45	12	1
12		□	1080-L12C	216	171	167	45	12	1
15		□	1080-L15C	249	204	200	45	12	1
20		□	1080-L20C	304	259	255	45	12	1
25		□	1080-L25C	359	314	310	45	12	1
5		★	1080LB	149	88	88	61	11	1
10		□	1080X10DB	207	146	143	61	11	1
20		□	1080X20DB	317	256	253	61	11	1
10.9		3	□	1090S-DIN	102	57	55	45	12
	3	□	1090S-DIN-C	102	57	55	45	12	1
	5	□	1090L-DIN	118	73	71	45	12	2
	5	□	1090L-DIN-C	118	73	71	45	12	1
	8	□	1090-L8C	172	127	123	45	12	1
	10	□	1090-L10C	194	149	145	45	12	1
	12	□	1090-L12C	216	171	167	45	12	1
	15	□	1090-L15C	249	204	200	45	12	1
	20	□	1090-L20C	304	259	255	45	12	1
	25	□	1090-L25C	359	314	310	45	12	1
	5	★	1090LB	149	88	88	61	11	1
	10	□	1090X10DB	207	146	143	61	11	1
	20	□	1090X20DB	317	256	253	61	11	1
	11.0	3	□	1100S-DIN	102	57	55	45	12
3		□	1100S-DIN-C	102	57	55	45	12	1
5		□	1100L-DIN	118	73	71	45	12	2
5		●	1100L-DIN-C	118	73	71	45	12	1
8		□	1100-L8C	172	127	123	45	12	1
10		□	1100-L10C	194	149	145	45	12	1
12		●	1100-L12C	216	171	167	45	12	1
15		□	1100-L15C	249	204	200	45	12	1
20		●	1100-L20C	304	259	255	45	12	1
25		□	1100-L25C	359	314	310	45	12	1
5		★	1100LB	149	88	88	61	11	1
10		★	1100X10DB	207	146	143	61	11	1
20		★	1100X20DB	317	256	253	61	11	1

# СВЕРЛЕНИЕ (МОНОЛИТНЫЕ ТВЕРДОСПЛАВНЫЕ СВЕРЛА)

## MNS

ТВЕРДЫЙ  
СПЛАВ

Диам. сверла D1 (мм)	Глубина сверления (l/d)	Наличие TF15	Обозначение	Размеры (мм)					Тип
				L1	L2	L3	L9	D4	
11.1	3	□	MNS1110S-DIN	102	57	55	45	12	2
	3	□	1110S-DIN-C	102	57	55	45	12	1
	5	□	1110L-DIN	118	73	71	45	12	2
	5	□	1110L-DIN-C	118	73	71	45	12	1
	8	□	1110-L8C	178	133	129	45	12	1
	10	□	1110-L10C	201	156	152	45	12	1
	12	□	1110-L12C	224	179	175	45	12	1
	15	□	1110-L15C	258	213	209	45	12	1
	20	□	1110-L20C	316	271	267	45	12	1
	25	□	1110-L25C	373	328	324	45	12	1
	5	★	1110LB	158	96	92	62	12	1
	10	□	1110X10DB	215	153	150	62	12	1
	20	□	1110X20DB	330	268	265	62	12	1
	11.2	3	□	1120S-DIN	102	57	55	45	12
3		□	1120S-DIN-C	102	57	55	45	12	1
5		□	1120L-DIN	118	73	71	45	12	2
5		□	1120L-DIN-C	118	73	71	45	12	1
8		□	1120-L8C	178	133	129	45	12	1
10		□	1120-L10C	201	156	152	45	12	1
12		□	1120-L12C	224	179	175	45	12	1
15		□	1120-L15C	258	213	209	45	12	1
20		□	1120-L20C	316	271	267	45	12	1
25		□	1120-L25C	373	328	324	45	12	1
5		★	1120LB	158	96	92	62	12	1
10		□	1120X10DB	215	153	150	62	12	1
20		□	1120X20DB	330	268	265	62	12	1
11.3		3	□	1130S-DIN	102	57	55	45	12
	3	□	1130S-DIN-C	102	57	55	45	12	1
	5	□	1130L-DIN	118	73	71	45	12	2
	5	□	1130L-DIN-C	118	73	71	45	12	1
	8	□	1130-L8C	178	133	129	45	12	1
	10	□	1130-L10C	201	156	152	45	12	1
	12	□	1130-L12C	224	179	175	45	12	1
	15	□	1130-L15C	258	213	209	45	12	1
	20	□	1130-L20C	316	271	267	45	12	1
	25	□	1130-L25C	373	328	324	45	12	1
	5	★	1130LB	158	96	92	62	12	1
	10	□	1130X10DB	215	153	150	62	12	1
	20	□	1130X20DB	330	268	265	62	12	1
	11.4	3	□	1140S-DIN	102	57	55	45	12
3		□	1140S-DIN-C	102	57	55	45	12	1
5		□	1140L-DIN	118	73	71	45	12	2
5		□	1140L-DIN-C	118	73	71	45	12	1
8		□	1140-L8C	178	133	129	45	12	1
10		□	1140-L10C	201	156	152	45	12	1
12		□	1140-L12C	224	179	175	45	12	1

Диам. сверла D1 (мм)	Глубина сверления (l/d)	Наличие TF15	Обозначение	Размеры (мм)					Тип
				L1	L2	L3	L9	D4	
11.4	15	□	MNS1140-L15C	258	213	209	45	12	1
	20	□	1140-L20C	316	271	267	45	12	1
	25	□	1140-L25C	373	328	324	45	12	1
	5	★	1140LB	158	96	92	62	12	1
	10	□	1140X10DB	215	153	150	62	12	1
	20	□	1140X20DB	330	268	265	62	12	1
	11.5	3	□	1150S-DIN	102	57	55	45	12
3		□	1150S-DIN-C	102	57	55	45	12	1
5		□	1150L-DIN	118	73	71	45	12	2
5		●	1150L-DIN-C	118	73	71	45	12	1
8		□	1150-L8C	178	133	129	45	12	1
10		□	1150-L10C	201	156	152	45	12	1
12		●	1150-L12C	224	179	175	45	12	1
15		□	1150-L15C	258	213	209	45	12	1
20		●	1150-L20C	316	271	267	45	12	1
25		□	1150-L25C	373	328	324	45	12	1
5		★	1150LB	158	96	92	62	12	1
10		□	1150X10DB	215	153	150	62	12	1
20		□	1150X20DB	330	268	265	62	12	1
11.6		3	□	1160S-DIN	102	57	55	45	12
	3	□	1160S-DIN-C	102	57	55	45	12	1
	5	□	1160L-DIN	118	73	71	45	12	2
	5	□	1160L-DIN-C	118	73	71	45	12	1
	8	□	1160-L8C	183	138	134	45	12	1
	10	□	1160-L10C	207	162	158	45	12	1
	12	□	1160-L12C	231	186	182	45	12	1
	15	□	1160-L15C	267	222	218	45	12	1
	20	□	1160-L20C	327	282	278	45	12	1
	25	□	1160-L25C	387	342	338	45	12	1
	5	★	1160LB	158	96	96	62	12	1
	10	□	1160X10DB	221	159	156	62	12	1
	20	□	1160X20DB	341	279	276	62	12	1
	11.7	3	□	1170S-DIN	102	57	55	45	12
3		□	1170S-DIN-C	102	57	55	45	12	1
5		□	1170L-DIN	118	73	71	45	12	2
5		□	1170L-DIN-C	118	73	71	45	12	1
8		□	1170-L8C	183	138	134	45	12	1
10		□	1170-L10C	207	162	158	45	12	1
12		□	1170-L12C	231	186	182	45	12	1
15		□	1170-L15C	267	222	218	45	12	1
20		□	1170-L20C	327	282	278	45	12	1
25		□	1170-L25C	387	342	338	45	12	1
5		★	1170LB	158	96	96	62	12	1
10		□	1170X10DB	221	159	156	62	12	1
20		□	1170X20DB	341	279	276	62	12	1

(Примечание) Пожалуйста, свяжитесь с нами если Вы не нашли нужную геометрию в данном каталоге (могут быть заказаны другие диаметры и длины).

● : Есть на складе. ★ : Со склада в Японии.

□ : Нет на складе, выпускается исключительно под заказ.

L086

Заказ инструмента: <http://steelcam.org> | 8 (343) 382-52-03 | [sales@sverla-ekb.ru](mailto:sales@sverla-ekb.ru)

СВЕРЛЕНИЕ

Диам. сверла D1 (мм)	Глубина сверления (l/d)	Наличие TF15	Обозначение	Размеры (мм)					Тип
				L1	L2	L3	L9	D4	
11.8	3	□	MNS1180S-DIN	102	57	55	45	12	2
	3	□	1180S-DIN-C	102	57	55	45	12	1
	5	□	1180L-DIN	118	73	71	45	12	2
	5	□	1180L-DIN-C	118	73	71	45	12	1
	8	□	1180-L8C	183	138	134	45	12	1
	10	□	1180-L10C	207	162	158	45	12	1
	12	□	1180-L12C	231	186	182	45	12	1
	15	□	1180-L15C	267	222	218	45	12	1
	20	□	1180-L20C	327	282	278	45	12	1
	25	□	1180-L25C	387	342	338	45	12	1
	5	★	1180LB	158	96	96	62	12	1
	10	□	1180X10DB	221	159	156	62	12	1
20	□	1180X20DB	341	279	276	62	12	1	
11.9	3	□	1190S-DIN	102	57	55	45	12	2
	3	□	1190S-DIN-C	102	57	55	45	12	1
	5	□	1190L-DIN	118	73	71	45	12	2
	5	□	1190L-DIN-C	118	73	71	45	12	1
	8	□	1190-L8C	183	138	134	45	12	1
	10	□	1190-L10C	207	162	158	45	12	1
	12	□	1190-L12C	231	186	182	45	12	1
	15	□	1190-L15C	267	222	218	45	12	1
	20	□	1190-L20C	327	282	278	45	12	1
	25	□	1190-L25C	387	342	338	45	12	1
	5	★	1190LB	158	96	96	62	12	1
	10	□	1190X10DB	221	159	156	62	12	1
20	□	1190X20DB	341	279	276	62	12	1	
12.0	3	□	1200S-DIN	102	57	55	45	12	2
	3	□	1200S-DIN-C	102	57	55	45	12	1
	5	□	1200L-DIN	118	73	71	45	12	2
	5	●	1200L-DIN-C	118	73	71	45	12	1
	8	□	1200-L8C	183	138	134	45	12	1
	10	□	1200-L10C	207	162	158	45	12	1
	12	●	1200-L12C	231	186	182	45	12	1
	15	□	1200-L15C	267	222	218	45	12	1
	20	●	1200-L20C	327	282	278	45	12	1
	25	□	1200-L25C	387	342	338	45	12	1
	5	★	1200LB	158	96	96	62	12	1
	10	★	1200X10DB	221	159	156	62	12	1
20	★	1200X20DB	341	279	276	62	12	1	
12.1	3	□	1210S-DIN	107	62	60	45	14	2
	3	□	1210S-DIN-C	107	62	60	45	14	1
	5	□	1210L-DIN	124	79	77	45	14	2
	5	□	1210L-DIN-C	124	79	77	45	14	1
	8	□	1210-L8C	189	144	140	45	14	1
	10	□	1210-L10C	214	169	165	45	14	1
	12	□	1210-L12C	239	194	190	45	14	1
	15	□	1210-L15C	276	231	227	45	14	1
	20	□	1210-L20C	339	294	290	45	14	1
	5	★	1210LB	167	104	100	63	13	1
	10	□	1210X10DB	229	166	163	63	13	1
	20	□	1210X20DB	354	291	288	63	13	1

Диам. сверла D1 (мм)	Глубина сверления (l/d)	Наличие TF15	Обозначение	Размеры (мм)					Тип
				L1	L2	L3	L9	D4	
12.2	3	□	MNS1220S-DIN	107	62	60	45	14	2
	3	□	1220S-DIN-C	107	62	60	45	14	1
	5	□	1220L-DIN	124	79	77	45	14	2
	5	□	1220L-DIN-C	124	79	77	45	14	1
	8	□	1220-L8C	189	144	140	45	14	1
	10	□	1220-L10C	214	169	165	45	14	1
	12	□	1220-L12C	239	194	190	45	14	1
	15	□	1220-L15C	276	231	227	45	14	1
	20	□	1220-L20C	339	294	290	45	14	1
	5	★	1220LB	167	104	100	63	13	1
	10	□	1220X10DB	229	166	163	63	13	1
	20	□	1220X20DB	354	291	288	63	13	1
12.3	3	□	1230S-DIN	107	62	60	45	14	2
	3	□	1230S-DIN-C	107	62	60	45	14	1
	5	□	1230L-DIN	124	79	77	45	14	2
	5	□	1230L-DIN-C	124	79	77	45	14	1
	8	□	1230-L8C	189	144	140	45	14	1
	10	□	1230-L10C	214	169	165	45	14	1
	12	□	1230-L12C	239	194	190	45	14	1
	15	□	1230-L15C	276	231	227	45	14	1
	20	□	1230-L20C	339	294	290	45	14	1
	5	★	1230LB	167	104	100	63	13	1
	10	□	1230X10DB	229	166	163	63	13	1
	20	□	1230X20DB	354	291	288	63	13	1
12.4	3	□	1240S-DIN	107	62	60	45	14	2
	3	□	1240S-DIN-C	107	62	60	45	14	1
	5	□	1240L-DIN	124	79	77	45	14	2
	5	□	1240L-DIN-C	124	79	77	45	14	1
	8	□	1240-L8C	189	144	140	45	14	1
	10	□	1240-L10C	214	169	165	45	14	1
	12	□	1240-L12C	239	194	190	45	14	1
	15	□	1240-L15C	276	231	227	45	14	1
	20	□	1240-L20C	339	294	290	45	14	1
	5	★	1240LB	167	104	100	63	13	1
	10	□	1240X10DB	229	166	163	63	13	1
	20	□	1240X20DB	354	291	288	63	13	1
12.5	3	□	1250S-DIN	107	62	60	45	14	2
	3	□	1250S-DIN-C	107	62	60	45	14	1
	5	□	1250L-DIN	124	79	77	45	14	2
	5	●	1250L-DIN-C	124	79	77	45	14	1
	8	□	1250-L8C	189	144	140	45	14	1
	10	□	1250-L10C	214	169	165	45	14	1
	12	●	1250-L12C	239	194	190	45	14	1
	15	□	1250-L15C	276	231	227	45	14	1
	20	●	1250-L20C	339	294	290	45	14	1
	5	★	1250LB	167	104	100	63	13	1
	10	□	1250X10DB	229	166	163	63	13	1
	20	□	1250X20DB	354	291	288	63	13	1

# СВЕРЛЕНИЕ (МОНОЛИТНЫЕ ТВЕРДОСПЛАВНЫЕ СВЕРЛА)

## MNS

ТВЕРДЫЙ  
СПЛАВ

Диам. сверла D1 (мм)	Глубина сверления (l/d)	Наличие TF15	Обозначение	Размеры (мм)					Тип
				L1	L2	L3	L9	D4	
12.6	3	<input type="checkbox"/>	MNS1260S-DIN	107	62	60	45	14	2
	3	<input type="checkbox"/>	1260S-DIN-C	107	62	60	45	14	1
	5	<input type="checkbox"/>	1260L-DIN	124	79	77	45	14	2
	5	<input type="checkbox"/>	1260L-DIN-C	124	79	77	45	14	1
	8	<input type="checkbox"/>	1260-L8C	194	149	145	45	14	1
	10	<input type="checkbox"/>	1260-L10C	220	175	171	45	14	1
	12	<input type="checkbox"/>	1260-L12C	246	201	197	45	14	1
	15	<input type="checkbox"/>	1260-L15C	285	240	236	45	14	1
	20	<input type="checkbox"/>	1260-L20C	350	305	301	45	14	1
	5	<input checked="" type="checkbox"/>	1260LB	167	104	104	63	13	1
10	<input type="checkbox"/>	1260X10DB	235	172	169	63	13	1	
20	<input type="checkbox"/>	1260X20DB	365	302	299	63	13	1	
12.7	3	<input type="checkbox"/>	1270S-DIN	107	62	60	45	14	2
	3	<input type="checkbox"/>	1270S-DIN-C	107	62	60	45	14	1
	5	<input type="checkbox"/>	1270L-DIN	124	79	77	45	14	2
	5	<input type="checkbox"/>	1270L-DIN-C	124	79	77	45	14	1
	8	<input type="checkbox"/>	1270-L8C	194	149	145	45	14	1
	10	<input type="checkbox"/>	1270-L10C	220	175	171	45	14	1
	12	<input type="checkbox"/>	1270-L12C	246	201	197	45	14	1
	15	<input type="checkbox"/>	1270-L15C	285	240	236	45	14	1
	20	<input type="checkbox"/>	1270-L20C	350	305	301	45	14	1
	5	<input checked="" type="checkbox"/>	1270LB	167	104	104	63	13	1
10	<input type="checkbox"/>	1270X10DB	235	172	169	63	13	1	
20	<input type="checkbox"/>	1270X20DB	365	302	299	63	13	1	
12.8	3	<input type="checkbox"/>	1280S-DIN	107	62	60	45	14	2
	3	<input type="checkbox"/>	1280S-DIN-C	107	62	60	45	14	1
	5	<input type="checkbox"/>	1280L-DIN	124	79	77	45	14	2
	5	<input type="checkbox"/>	1280L-DIN-C	124	79	77	45	14	1
	8	<input type="checkbox"/>	1280-L8C	194	149	145	45	14	1
	10	<input type="checkbox"/>	1280-L10C	220	175	171	45	14	1
	12	<input type="checkbox"/>	1280-L12C	246	201	197	45	14	1
	15	<input type="checkbox"/>	1280-L15C	285	240	236	45	14	1
	20	<input type="checkbox"/>	1280-L20C	350	305	301	45	14	1
	5	<input checked="" type="checkbox"/>	1280LB	167	104	104	63	13	1
10	<input type="checkbox"/>	1280X10DB	235	172	169	63	13	1	
20	<input type="checkbox"/>	1280X20DB	365	302	299	63	13	1	
12.9	3	<input type="checkbox"/>	1290S-DIN	107	62	60	45	14	2
	3	<input type="checkbox"/>	1290S-DIN-C	107	62	60	45	14	1
	5	<input type="checkbox"/>	1290L-DIN	124	79	77	45	14	2
	5	<input type="checkbox"/>	1290L-DIN-C	124	79	77	45	14	1
	8	<input type="checkbox"/>	1290-L8C	194	149	145	45	14	1
	10	<input type="checkbox"/>	1290-L10C	220	175	171	45	14	1
	12	<input type="checkbox"/>	1290-L12C	246	201	197	45	14	1
	15	<input type="checkbox"/>	1290-L15C	285	240	236	45	14	1
	20	<input type="checkbox"/>	1290-L20C	350	305	301	45	14	1
	5	<input checked="" type="checkbox"/>	1290LB	167	104	104	63	13	1
10	<input type="checkbox"/>	1290X10DB	235	172	169	63	13	1	
20	<input type="checkbox"/>	1290X20DB	365	302	299	63	13	1	

Диам. сверла D1 (мм)	Глубина сверления (l/d)	Наличие TF15	Обозначение	Размеры (мм)					Тип
				L1	L2	L3	L9	D4	
13.0	3	<input type="checkbox"/>	MNS1300S-DIN	107	62	60	45	14	2
	3	<input type="checkbox"/>	1300S-DIN-C	107	62	60	45	14	1
	5	<input type="checkbox"/>	1300L-DIN	124	79	77	45	14	2
	5	<input checked="" type="checkbox"/>	1300L-DIN-C	124	79	77	45	14	1
	8	<input type="checkbox"/>	1300-L8C	194	149	145	45	14	1
	10	<input type="checkbox"/>	1300-L10C	220	175	171	45	14	1
	12	<input checked="" type="checkbox"/>	1300-L12C	246	201	197	45	14	1
	15	<input type="checkbox"/>	1300-L15C	285	240	236	45	14	1
	20	<input checked="" type="checkbox"/>	1300-L20C	350	305	301	45	14	1
	5	<input checked="" type="checkbox"/>	1300LB	167	104	104	63	13	1
10	<input checked="" type="checkbox"/>	1300X10DB	235	172	169	63	13	1	
20	<input checked="" type="checkbox"/>	1300X20DB	365	302	299	63	13	1	
13.1	3	<input type="checkbox"/>	1310S-DIN	107	62	60	45	14	2
	3	<input type="checkbox"/>	1310S-DIN-C	107	62	60	45	14	1
	5	<input type="checkbox"/>	1310L-DIN	124	79	77	45	14	2
	5	<input type="checkbox"/>	1310L-DIN-C	124	79	77	45	14	1
	8	<input type="checkbox"/>	1310-L8C	200	155	151	45	14	1
	10	<input type="checkbox"/>	1310-L10C	227	182	178	45	14	1
	12	<input type="checkbox"/>	1310-L12C	254	209	205	45	14	1
	15	<input type="checkbox"/>	1310-L15C	294	249	245	45	14	1
	20	<input type="checkbox"/>	1310-L20C	362	317	313	45	14	1
	5	<input checked="" type="checkbox"/>	1310LB	176	112	108	64	14	1
10	<input type="checkbox"/>	1310X10DB	243	179	176	64	14	1	
20	<input type="checkbox"/>	1310X20DB	378	314	311	64	14	1	
13.2	3	<input type="checkbox"/>	1320S-DIN	107	62	60	45	14	2
	3	<input type="checkbox"/>	1320S-DIN-C	107	62	60	45	14	1
	5	<input type="checkbox"/>	1320L-DIN	124	79	77	45	14	2
	5	<input type="checkbox"/>	1320L-DIN-C	124	79	77	45	14	1
	8	<input type="checkbox"/>	1320-L8C	200	155	151	45	14	1
	10	<input type="checkbox"/>	1320-L10C	227	182	178	45	14	1
	12	<input type="checkbox"/>	1320-L12C	254	209	205	45	14	1
	15	<input type="checkbox"/>	1320-L15C	294	249	245	45	14	1
	20	<input type="checkbox"/>	1320-L20C	362	317	313	45	14	1
	5	<input checked="" type="checkbox"/>	1320LB	176	112	108	64	14	1
10	<input type="checkbox"/>	1320X10DB	243	179	176	64	14	1	
20	<input type="checkbox"/>	1320X20DB	378	314	311	64	14	1	
13.3	3	<input type="checkbox"/>	1330S-DIN	107	62	60	45	14	2
	3	<input type="checkbox"/>	1330S-DIN-C	107	62	60	45	14	1
	5	<input type="checkbox"/>	1330L-DIN	124	79	77	45	14	2
	5	<input type="checkbox"/>	1330L-DIN-C	124	79	77	45	14	1
	8	<input type="checkbox"/>	1330-L8C	200	155	151	45	14	1
	10	<input type="checkbox"/>	1330-L10C	227	182	178	45	14	1
	12	<input type="checkbox"/>	1330-L12C	254	209	205	45	14	1
	15	<input type="checkbox"/>	1330-L15C	294	249	245	45	14	1
	20	<input type="checkbox"/>	1330-L20C	362	317	313	45	14	1
	5	<input checked="" type="checkbox"/>	1330LB	176	112	108	64	14	1
10	<input type="checkbox"/>	1330X10DB	243	179	176	64	14	1	
20	<input type="checkbox"/>	1330X20DB	378	314	311	64	14	1	

(Примечание) Пожалуйста, свяжитесь с нами если Вы не нашли нужную геометрию в данном каталоге (могут быть заказаны другие диаметры и длины).

● : Есть на складе. ★ : Со склада в Японии.

□ : Нет на складе, выпускается исключительно под заказ.

L088

Заказ инструмента: <http://steelcam.org> | 8 (343) 382-52-03 | [sales@sverla-ekb.ru](mailto:sales@sverla-ekb.ru)

Диам. сверла D1 (мм)	Глубина сверления (l/d)	Наличие TF15	Обозначение	Размеры (мм)					Тип
				L1	L2	L3	L9	D4	
13.4	3	□	MNS1340S-DIN	107	62	60	45	14	2
	3	□	1340S-DIN-C	107	62	60	45	14	1
	5	□	1340L-DIN	124	79	77	45	14	2
	5	□	1340L-DIN-C	124	79	77	45	14	1
	8	□	1340-L8C	200	155	151	45	14	1
	10	□	1340-L10C	227	182	178	45	14	1
	12	□	1340-L12C	254	209	205	45	14	1
	15	□	1340-L15C	294	249	245	45	14	1
	20	□	1340-L20C	362	317	313	45	14	1
	5	★	1340LB	176	112	108	64	14	1
	10	□	1340X10DB	243	179	176	64	14	1
20	□	1340X20DB	378	314	311	64	14	1	
13.5	3	□	1350S-DIN	107	62	60	45	14	2
	3	□	1350S-DIN-C	107	62	60	45	14	1
	5	□	1350L-DIN	124	79	77	45	14	2
	5	●	1350L-DIN-C	124	79	77	45	14	1
	8	□	1350-L8C	200	155	151	45	14	1
	10	□	1350-L10C	227	182	178	45	14	1
	12	●	1350-L12C	254	209	205	45	14	1
	15	□	1350-L15C	294	249	245	45	14	1
	20	●	1350-L20C	362	317	313	45	14	1
	5	★	1350LB	176	112	108	64	14	1
	10	□	1350X10DB	243	179	176	64	14	1
20	□	1350X20DB	378	314	311	64	14	1	
13.6	3	□	1360S-DIN	107	62	60	45	14	2
	3	□	1360S-DIN-C	107	62	60	45	14	1
	5	□	1360L-DIN	124	79	77	45	14	2
	5	□	1360L-DIN-C	124	79	77	45	14	1
	8	□	1360-L8C	205	160	156	45	14	1
	10	□	1360-L10C	233	188	184	45	14	1
	12	□	1360-L12C	261	216	212	45	14	1
	15	□	1360-L15C	303	258	254	45	14	1
	20	□	1360-L20C	373	328	324	45	14	1
	5	★	1360LB	176	112	112	64	14	1
	10	□	1360X10DB	249	185	182	64	14	1
20	□	1360X20DB	389	325	322	64	14	1	
13.7	3	□	1370S-DIN	107	62	60	45	14	2
	3	□	1370S-DIN-C	107	62	60	45	14	1
	5	□	1370L-DIN	124	79	77	45	14	2
	5	□	1370L-DIN-C	124	79	77	45	14	1
	8	□	1370-L8C	205	160	156	45	14	1
	10	□	1370-L10C	233	188	184	45	14	1
	12	□	1370-L12C	261	216	212	45	14	1
	15	□	1370-L15C	303	258	254	45	14	1
	20	□	1370-L20C	373	328	324	45	14	1
	5	★	1370LB	176	112	112	64	14	1
	10	□	1370X10DB	249	185	182	64	14	1
20	□	1370X20DB	389	325	322	64	14	1	

Диам. сверла D1 (мм)	Глубина сверления (l/d)	Наличие TF15	Обозначение	Размеры (мм)					Тип
				L1	L2	L3	L9	D4	
13.8	3	□	MNS1380S-DIN	107	62	60	45	14	2
	3	□	1380S-DIN-C	107	62	60	45	14	1
	5	□	1380L-DIN	124	79	77	45	14	2
	5	□	1380L-DIN-C	124	79	77	45	14	1
	8	□	1380-L8C	205	160	156	45	14	1
	10	□	1380-L10C	233	188	184	45	14	1
	12	□	1380-L12C	261	216	212	45	14	1
	15	□	1380-L15C	303	258	254	45	14	1
	20	□	1380-L20C	373	328	324	45	14	1
	5	★	1380LB	176	112	112	64	14	1
	10	□	1380X10DB	249	185	182	64	14	1
20	□	1380X20DB	389	325	322	64	14	1	
13.9	3	□	1390S-DIN	107	62	60	45	14	2
	3	□	1390S-DIN-C	107	62	60	45	14	1
	5	□	1390L-DIN	124	79	77	45	14	2
	5	□	1390L-DIN-C	124	79	77	45	14	1
	8	□	1390-L8C	205	160	156	45	14	1
	10	□	1390-L10C	233	188	184	45	14	1
	12	□	1390-L12C	261	216	212	45	14	1
	15	□	1390-L15C	303	258	254	45	14	1
	20	□	1390-L20C	373	328	324	45	14	1
	5	★	1390LB	176	112	112	64	14	1
	10	□	1390X10DB	249	185	182	64	14	1
20	□	1390X20DB	389	325	322	64	14	1	
14.0	3	□	1400S-DIN	107	62	60	45	14	2
	3	□	1400S-DIN-C	107	62	60	45	14	1
	5	□	1400L-DIN	124	79	77	45	14	2
	5	●	1400L-DIN-C	124	79	77	45	14	1
	8	□	1400-L8C	205	160	156	45	14	1
	10	□	1400-L10C	233	188	184	45	14	1
	12	●	1400-L12C	261	216	212	45	14	1
	15	□	1400-L15C	303	258	254	45	14	1
	20	●	1400-L20C	373	328	324	45	14	1
	5	★	1400LB	176	112	112	64	14	1
	10	★	1400X10DB	249	185	182	64	14	1
20	★	1400X20DB	389	325	322	64	14	1	
14.1	3	□	1410S-DIN	114	66	64	48	16	2
	3	□	1410S-DIN-C	114	66	64	48	16	1
	5	□	1410L-DIN	132	84	82	48	16	2
	5	□	1410L-DIN-C	132	84	82	48	16	1
14.2	3	□	1420S-DIN	114	66	64	48	16	2
	3	□	1420S-DIN-C	114	66	64	48	16	1
	5	□	1420L-DIN	132	84	82	48	16	2
	5	●	1420L-DIN-C	132	84	82	48	16	1
14.3	3	□	1430S-DIN	114	66	64	48	16	2
	3	□	1430S-DIN-C	114	66	64	48	16	1
	5	□	1430L-DIN	132	84	82	48	16	2
	5	□	1430L-DIN-C	132	84	82	48	16	1

# СВЕРЛЕНИЕ (МОНОЛИТНЫЕ ТВЕРДОСПЛАВНЫЕ СВЕРЛА)

## MNS

ТВЕРДЫЙ  
СПЛАВ

Диам. сверла D1 (мм)	Глубина сверления (l/d)	Наличие TF15	Обозначение	Размеры (мм)					Тип
				L1	L2	L3	L9	D4	
14.4	3	<input type="checkbox"/>	MNS1440S-DIN	114	66	64	48	16	2
	3	<input type="checkbox"/>	1440S-DIN-C	114	66	64	48	16	1
	5	<input type="checkbox"/>	1440L-DIN	132	84	82	48	16	2
	5	<input type="checkbox"/>	1440L-DIN-C	132	84	82	48	16	1
14.5	3	<input type="checkbox"/>	1450S-DIN	114	66	64	48	16	2
	3	<input type="checkbox"/>	1450S-DIN-C	114	66	64	48	16	1
	5	<input type="checkbox"/>	1450L-DIN	132	84	82	48	16	2
	5	<input checked="" type="checkbox"/>	1450L-DIN-C	132	84	82	48	16	1
14.6	3	<input type="checkbox"/>	1460S-DIN	114	66	64	48	16	2
	3	<input type="checkbox"/>	1460S-DIN-C	114	66	64	48	16	1
	5	<input type="checkbox"/>	1460L-DIN	132	84	82	48	16	2
	5	<input type="checkbox"/>	1460L-DIN-C	132	84	82	48	16	1
14.7	3	<input type="checkbox"/>	1470S-DIN	114	66	64	48	16	2
	3	<input type="checkbox"/>	1470S-DIN-C	114	66	64	48	16	1
	5	<input type="checkbox"/>	1470L-DIN	132	84	82	48	16	2
	5	<input type="checkbox"/>	1470L-DIN-C	132	84	82	48	16	1
14.8	3	<input type="checkbox"/>	1480S-DIN	114	66	64	48	16	2
	3	<input type="checkbox"/>	1480S-DIN-C	114	66	64	48	16	1
	5	<input type="checkbox"/>	1480L-DIN	132	84	82	48	16	2
	5	<input type="checkbox"/>	1480L-DIN-C	132	84	82	48	16	1
14.9	3	<input type="checkbox"/>	1490S-DIN	114	66	64	48	16	2
	3	<input type="checkbox"/>	1490S-DIN-C	114	66	64	48	16	1
	5	<input type="checkbox"/>	1490L-DIN	132	84	82	48	16	2
	5	<input type="checkbox"/>	1490L-DIN-C	132	84	82	48	16	1
15.0	3	<input type="checkbox"/>	1500S-DIN	114	66	64	48	16	2
	3	<input type="checkbox"/>	1500S-DIN-C	114	66	64	48	16	1
	5	<input type="checkbox"/>	1500L-DIN	132	84	82	48	16	2
	5	<input checked="" type="checkbox"/>	1500L-DIN-C	132	84	82	48	16	1
15.1	3	<input type="checkbox"/>	1510S-DIN	115	67	65	48	16	2
	3	<input type="checkbox"/>	1510S-DIN-C	115	67	65	48	16	1
	5	<input type="checkbox"/>	1510L-DIN	133	85	83	48	16	2
	5	<input type="checkbox"/>	1510L-DIN-C	133	85	83	48	16	1
15.2	3	<input type="checkbox"/>	1520S-DIN	115	67	65	48	16	2
	3	<input type="checkbox"/>	1520S-DIN-C	115	67	65	48	16	1
	5	<input type="checkbox"/>	1520L-DIN	133	85	83	48	16	2
	5	<input type="checkbox"/>	1520L-DIN-C	133	85	83	48	16	1
15.3	3	<input type="checkbox"/>	1530S-DIN	115	67	65	48	16	2
	3	<input type="checkbox"/>	1530S-DIN-C	115	67	65	48	16	1
	5	<input type="checkbox"/>	1530L-DIN	133	85	83	48	16	2
	5	<input type="checkbox"/>	1530L-DIN-C	133	85	83	48	16	1
15.4	3	<input type="checkbox"/>	1540S-DIN	115	67	65	48	16	2
	3	<input type="checkbox"/>	1540S-DIN-C	115	67	65	48	16	1
	5	<input type="checkbox"/>	1540L-DIN	133	85	83	48	16	2
	5	<input type="checkbox"/>	1540L-DIN-C	133	85	83	48	16	1
15.5	3	<input type="checkbox"/>	1550S-DIN	115	67	65	48	16	2
	3	<input type="checkbox"/>	1550S-DIN-C	115	67	65	48	16	1
	5	<input type="checkbox"/>	1550L-DIN	133	85	83	48	16	2
	5	<input checked="" type="checkbox"/>	1550L-DIN-C	133	85	83	48	16	1

Диам. сверла D1 (мм)	Глубина сверления (l/d)	Наличие TF15	Обозначение	Размеры (мм)					Тип
				L1	L2	L3	L9	D4	
15.6	3	<input type="checkbox"/>	MNS1560S-DIN	115	67	65	48	16	2
	3	<input type="checkbox"/>	1560S-DIN-C	115	67	65	48	16	1
	5	<input type="checkbox"/>	1560L-DIN	133	85	83	48	16	2
	5	<input type="checkbox"/>	1560L-DIN-C	133	85	83	48	16	1
15.7	3	<input type="checkbox"/>	1570S-DIN	115	67	65	48	16	2
	3	<input type="checkbox"/>	1570S-DIN-C	115	67	65	48	16	1
	5	<input type="checkbox"/>	1570L-DIN	133	85	83	48	16	2
	5	<input type="checkbox"/>	1570L-DIN-C	133	85	83	48	16	1
15.8	3	<input type="checkbox"/>	1580S-DIN	115	67	65	48	16	2
	3	<input type="checkbox"/>	1580S-DIN-C	115	67	65	48	16	1
	5	<input type="checkbox"/>	1580L-DIN	133	85	83	48	16	2
	5	<input type="checkbox"/>	1580L-DIN-C	133	85	83	48	16	1
15.9	3	<input type="checkbox"/>	1590S-DIN	115	67	65	48	16	2
	3	<input type="checkbox"/>	1590S-DIN-C	115	67	65	48	16	1
	5	<input type="checkbox"/>	1590L-DIN	133	85	83	48	16	2
	5	<input type="checkbox"/>	1590L-DIN-C	133	85	83	48	16	1
16.0	3	<input type="checkbox"/>	1600S-DIN	115	67	65	48	16	2
	3	<input type="checkbox"/>	1600S-DIN-C	115	67	65	48	16	1
	5	<input type="checkbox"/>	1600L-DIN	133	85	83	48	16	2
	5	<input checked="" type="checkbox"/>	1600L-DIN-C	133	85	83	48	16	1
16.1	3	<input type="checkbox"/>	1610S-DIN	123	75	73	48	18	2
	3	<input type="checkbox"/>	1610S-DIN-C	123	75	73	48	18	1
	5	<input type="checkbox"/>	1610L-DIN	143	95	93	48	18	2
	5	<input type="checkbox"/>	1610L-DIN-C	143	95	93	48	18	1
16.2	3	<input type="checkbox"/>	1620S-DIN	123	75	73	48	18	2
	3	<input type="checkbox"/>	1620S-DIN-C	123	75	73	48	18	1
	5	<input type="checkbox"/>	1620L-DIN	143	95	93	48	18	2
	5	<input type="checkbox"/>	1620L-DIN-C	143	95	93	48	18	1
16.3	3	<input type="checkbox"/>	1630S-DIN	123	75	73	48	18	2
	3	<input type="checkbox"/>	1630S-DIN-C	123	75	73	48	18	1
	5	<input type="checkbox"/>	1630L-DIN	143	95	93	48	18	2
	5	<input type="checkbox"/>	1630L-DIN-C	143	95	93	48	18	1
16.4	3	<input type="checkbox"/>	1640S-DIN	123	75	73	48	18	2
	3	<input type="checkbox"/>	1640S-DIN-C	123	75	73	48	18	1
	5	<input type="checkbox"/>	1640L-DIN	143	95	93	48	18	2
	5	<input type="checkbox"/>	1640L-DIN-C	143	95	93	48	18	1
16.5	3	<input type="checkbox"/>	1650S-DIN	123	75	73	48	18	2
	3	<input type="checkbox"/>	1650S-DIN-C	123	75	73	48	18	1
	5	<input type="checkbox"/>	1650L-DIN	143	95	93	48	18	2
	5	<input checked="" type="checkbox"/>	1650L-DIN-C	143	95	93	48	18	1
16.6	3	<input type="checkbox"/>	1660S-DIN	123	75	73	48	18	2
	3	<input type="checkbox"/>	1660S-DIN-C	123	75	73	48	18	1
	5	<input type="checkbox"/>	1660L-DIN	143	95	93	48	18	2
	5	<input type="checkbox"/>	1660L-DIN-C	143	95	93	48	18	1
16.7	3	<input type="checkbox"/>	1670S-DIN	123	75	73	48	18	2
	3	<input type="checkbox"/>	1670S-DIN-C	123	75	73	48	18	1
	5	<input type="checkbox"/>	1670L-DIN	143	95	93	48	18	2
	5	<input type="checkbox"/>	1670L-DIN-C	143	95	93	48	18	1

(Примечание) Пожалуйста, свяжитесь с нами если Вы не нашли нужную геометрию в данном каталоге (могут быть заказаны другие диаметры и длины).

● : Есть на складе. □ : Нет на складе, выпускается исключительно под заказ.

L090

Заказ инструмента: <http://steelcam.org> | 8 (343) 382-52-03 | [sales@sverla-ekb.ru](mailto:sales@sverla-ekb.ru)

СВЕРЛЕНИЕ

Диам. сверла D1 (мм)	Глубина сверления (l/d)	Наличие TF15	Обозначение	Размеры (мм)					Тип
				L1	L2	L3	L9	D4	
16.8	3	□	MNS1680S-DIN	123	75	73	48	18	2
	3	□	1680S-DIN-C	123	75	73	48	18	1
	5	□	1680L-DIN	143	95	93	48	18	2
	5	□	1680L-DIN-C	143	95	93	48	18	1
16.9	3	□	1690S-DIN	123	75	73	48	18	2
	3	□	1690S-DIN-C	123	75	73	48	18	1
	5	□	1690L-DIN	143	95	93	48	18	2
	5	□	1690L-DIN-C	143	95	93	48	18	1
17.0	3	□	1700S-DIN	123	75	73	48	18	2
	3	□	1700S-DIN-C	123	75	73	48	18	1
	5	□	1700L-DIN	143	95	93	48	18	2
	5	●	1700L-DIN-C	143	95	93	48	18	1
17.1	3	□	1710S-DIN	123	75	73	48	18	2
	3	□	1710S-DIN-C	123	75	73	48	18	1
	5	□	1710L-DIN	143	95	93	48	18	2
	5	□	1710L-DIN-C	143	95	93	48	18	1
17.2	3	□	1720S-DIN	123	75	73	48	18	2
	3	□	1720S-DIN-C	123	75	73	48	18	1
	5	□	1720L-DIN	143	95	93	48	18	2
	5	□	1720L-DIN-C	143	95	93	48	18	1
17.3	3	□	1730S-DIN	123	75	73	48	18	2
	3	□	1730S-DIN-C	123	75	73	48	18	1
	5	□	1730L-DIN	143	95	93	48	18	2
	5	□	1730L-DIN-C	143	95	93	48	18	1
17.4	3	□	1740S-DIN	123	75	73	48	18	2
	3	□	1740S-DIN-C	123	75	73	48	18	1
	5	□	1740L-DIN	143	95	93	48	18	2
	5	□	1740L-DIN-C	143	95	93	48	18	1
17.5	3	□	1750S-DIN	123	75	73	48	18	2
	3	□	1750S-DIN-C	123	75	73	48	18	1
	5	□	1750L-DIN	143	95	93	48	18	2
	5	●	1750L-DIN-C	143	95	93	48	18	1
17.6	3	□	1760S-DIN	123	75	73	48	18	2
	3	□	1760S-DIN-C	123	75	73	48	18	1
	5	□	1760L-DIN	143	95	93	48	18	2
	5	□	1760L-DIN-C	143	95	93	48	18	1
17.7	3	□	1770S-DIN	123	75	73	48	18	2
	3	□	1770S-DIN-C	123	75	73	48	18	1
	5	□	1770L-DIN	143	95	93	48	18	2
	5	□	1770L-DIN-C	143	95	93	48	18	1
17.8	3	□	1780S-DIN	123	75	73	48	18	2
	3	□	1780S-DIN-C	123	75	73	48	18	1
	5	□	1780L-DIN	143	95	93	48	18	2
	5	□	1780L-DIN-C	143	95	93	48	18	1
17.9	3	□	1790S-DIN	123	75	73	48	18	2
	3	□	1790S-DIN-C	123	75	73	48	18	1
	5	□	1790L-DIN	143	95	93	48	18	2
	5	□	1790L-DIN-C	143	95	93	48	18	1

Диам. сверла D1 (мм)	Глубина сверления (l/d)	Наличие TF15	Обозначение	Размеры (мм)					Тип
				L1	L2	L3	L9	D4	
18.0	3	□	MNS1800S-DIN	123	75	73	48	18	2
	3	□	1800S-DIN-C	123	75	73	48	18	1
	5	□	1800L-DIN	143	95	93	48	18	2
	5	●	1800L-DIN-C	143	95	93	48	18	1
18.1	3	□	1810S-DIN	131	81	79	50	20	2
	3	□	1810S-DIN-C	131	81	79	50	20	1
	5	□	1810L-DIN	153	103	101	50	20	2
	5	□	1810L-DIN-C	153	103	101	50	20	1
18.2	3	□	1820S-DIN	131	81	79	50	20	2
	3	□	1820S-DIN-C	131	81	79	50	20	1
	5	□	1820L-DIN	153	103	101	50	20	2
	5	□	1820L-DIN-C	153	103	101	50	20	1
18.3	3	□	1830S-DIN	131	81	79	50	20	2
	3	□	1830S-DIN-C	131	81	79	50	20	1
	5	□	1830L-DIN	153	103	101	50	20	2
	5	□	1830L-DIN-C	153	103	101	50	20	1
18.4	3	□	1840S-DIN	131	81	79	50	20	2
	3	□	1840S-DIN-C	131	81	79	50	20	1
	5	□	1840L-DIN	153	103	101	50	20	2
	5	□	1840L-DIN-C	153	103	101	50	20	1
18.5	3	□	1850S-DIN	131	81	79	50	20	2
	3	□	1850S-DIN-C	131	81	79	50	20	1
	5	□	1850L-DIN	153	103	101	50	20	2
	5	●	1850L-DIN-C	153	103	101	50	20	1
18.6	3	□	1860S-DIN	131	81	79	50	20	2
	3	□	1860S-DIN-C	131	81	79	50	20	1
	5	□	1860L-DIN	153	103	101	50	20	2
	5	□	1860L-DIN-C	153	103	101	50	20	1
18.7	3	□	1870S-DIN	131	81	79	50	20	2
	3	□	1870S-DIN-C	131	81	79	50	20	1
	5	□	1870L-DIN	153	103	101	50	20	2
	5	□	1870L-DIN-C	153	103	101	50	20	1
18.8	3	□	1880S-DIN	131	81	79	50	20	2
	3	□	1880S-DIN-C	131	81	79	50	20	1
	5	□	1880L-DIN	153	103	101	50	20	2
	5	□	1880L-DIN-C	153	103	101	50	20	1
18.9	3	□	1890S-DIN	131	81	79	50	20	2
	3	□	1890S-DIN-C	131	81	79	50	20	1
	5	□	1890L-DIN	153	103	101	50	20	2
	5	□	1890L-DIN-C	153	103	101	50	20	1
19.0	3	□	1900S-DIN	131	81	79	50	20	2
	3	□	1900S-DIN-C	131	81	79	50	20	1
	5	□	1900L-DIN	153	103	101	50	20	2
	5	□	1900L-DIN-C	153	103	101	50	20	1
19.1	3	□	1910S-DIN	131	81	79	50	20	2
	3	□	1910S-DIN-C	131	81	79	50	20	1
	5	□	1910L-DIN	153	103	101	50	20	2
	5	□	1910L-DIN-C	153	103	101	50	20	1

# СВЕРЛЕНИЕ (МОНОЛИТНЫЕ ТВЕРДОСПЛАВНЫЕ СВЕРЛА)

## MNS

ТВЕРДЫЙ  
СПЛАВ

Диам. сверла D1 (мм)	Глубина сверления (l/d)	Наличие TF15	Обозначение	Размеры (мм)					Тип
				L1	L2	L3	L9	D4	
19.2	3	<input type="checkbox"/>	MNS1920S-DIN	131	81	79	50	20	2
	3	<input type="checkbox"/>	1920S-DIN-C	131	81	79	50	20	1
	5	<input type="checkbox"/>	1920L-DIN	153	103	101	50	20	2
	5	<input type="checkbox"/>	1920L-DIN-C	153	103	101	50	20	1
19.3	3	<input type="checkbox"/>	1930S-DIN	131	81	79	50	20	2
	3	<input type="checkbox"/>	1930S-DIN-C	131	81	79	50	20	1
	5	<input type="checkbox"/>	1930L-DIN	153	103	101	50	20	2
	5	<input type="checkbox"/>	1930L-DIN-C	153	103	101	50	20	1
19.4	3	<input type="checkbox"/>	1940S-DIN	131	81	79	50	20	2
	3	<input type="checkbox"/>	1940S-DIN-C	131	81	79	50	20	1
	5	<input type="checkbox"/>	1940L-DIN	153	103	101	50	20	2
	5	<input type="checkbox"/>	1940L-DIN-C	153	103	101	50	20	1
19.5	3	<input type="checkbox"/>	1950S-DIN	131	81	79	50	20	2
	3	<input type="checkbox"/>	1950S-DIN-C	131	81	79	50	20	1
	5	<input type="checkbox"/>	1950L-DIN	153	103	101	50	20	2
	5	<input checked="" type="checkbox"/>	1950L-DIN-C	153	103	101	50	20	1
19.6	3	<input type="checkbox"/>	1960S-DIN	131	81	79	50	20	2
	3	<input type="checkbox"/>	1960S-DIN-C	131	81	79	50	20	1
	5	<input type="checkbox"/>	1960L-DIN	153	103	101	50	20	2
	5	<input type="checkbox"/>	1960L-DIN-C	153	103	101	50	20	1
19.7	3	<input type="checkbox"/>	1970S-DIN	131	81	79	50	20	2
	3	<input type="checkbox"/>	1970S-DIN-C	131	81	79	50	20	1
	5	<input type="checkbox"/>	1970L-DIN	153	103	101	50	20	2
	5	<input type="checkbox"/>	1970L-DIN-C	153	103	101	50	20	1
19.8	3	<input type="checkbox"/>	1980S-DIN	131	81	79	50	20	2
	3	<input type="checkbox"/>	1980S-DIN-C	131	81	79	50	20	1
	5	<input type="checkbox"/>	1980L-DIN	153	103	101	50	20	2
	5	<input type="checkbox"/>	1980L-DIN-C	153	103	101	50	20	1
19.9	3	<input type="checkbox"/>	1990S-DIN	131	81	79	50	20	2
	3	<input type="checkbox"/>	1990S-DIN-C	131	81	79	50	20	1
	5	<input type="checkbox"/>	1990L-DIN	153	103	101	50	20	2
	5	<input type="checkbox"/>	1990L-DIN-C	153	103	101	50	20	1
20.0	3	<input type="checkbox"/>	2000S-DIN	131	81	79	50	20	2
	3	<input type="checkbox"/>	2000S-DIN-C	131	81	79	50	20	1
	5	<input type="checkbox"/>	2000L-DIN	153	103	101	50	20	2
	5	<input checked="" type="checkbox"/>	2000L-DIN-C	153	103	101	50	20	1

(Примечание) Пожалуйста, свяжитесь с нами если Вы не нашли нужную геометрию в данном каталоге (могут быть заказаны другие диаметры и длины).

СВЕРЛЕНИЕ

● : Есть на складе. □ : Нет на складе, выпускается исключительно под заказ.

L092

Заказ инструмента: <http://steelcam.org> | 8 (343) 382-52-03 | [sales@sverla-ekb.ru](mailto:sales@sverla-ekb.ru)

## РЕКОМЕНДУЕМЫЕ РЕЖИМЫ РЕЗАНИЯ

## ■ Тип LB

Обрабатываемый материал	Алюминиевые сплавы (Si<5%)		Алюминиевые сплавы (5%≤Si≤10%)		Алюминиевые сплавы (Si>10%)		
	Диам. сверла (мм)	Частота вращения (мин <sup>-1</sup> )	Подача (мин.—макс.) (мм/об)	Частота вращения (мин <sup>-1</sup> )	Подача (мин.—макс.) (мм/об)	Частота вращения (мин <sup>-1</sup> )	Подача (мин.—макс.) (мм/об)
	<b>3.2</b>	11900	0.1 (0.11—0.16)	11900	0.15 (0.16—0.21)	11900	0.15 (0.16—0.21)
	<b>4.0</b>	9500	0.15 (0.13—0.20)	9500	0.2 (0.20—0.27)	9500	0.2 (0.20—0.27)
	<b>5.0</b>	7600	0.2 (0.17—0.25)	7600	0.25 (0.25—0.33)	7600	0.25 (0.25—0.33)
	<b>6.3</b>	7500	0.25 (0.21—0.32)	7500	0.35 (0.32—0.42)	7500	0.35 (0.32—0.42)
	<b>8.0</b>	5900	0.3 (0.27—0.40)	5900	0.45 (0.40—0.53)	5900	0.45 (0.40—0.53)
	<b>10.0</b>	4700	0.4 (0.33—0.50)	4700	0.55 (0.50—0.67)	4700	0.55 (0.50—0.67)
	<b>14.0</b>	5300	0.5 (0.40—0.60)	5300	0.7 (0.60—0.80)	5300	0.7 (0.60—0.80)

(Примечание 1) При сверлении отверстий с глубиной сверления свыше  $l/d=10$  рекомендуется сначала просверлить направляющее отверстие. (В противном случае возможна поломка сверла.)

(Примечание 2) Для предварительного сверления рекомендуются сверла Mitsubishi MNS, MAE-MB или MAS-MB.

## ■ Тип DB

Обрабатываемый материал	Алюминиевые сплавы (Si<5%)		Алюминиевые сплавы (5%≤Si≤10%)		Алюминиевые сплавы (Si>10%)		
	Диам. сверла (мм)	Частота вращения (мин <sup>-1</sup> )	Подача (мин.—макс.) (мм/об)	Частота вращения (мин <sup>-1</sup> )	Подача (мин.—макс.) (мм/об)	Частота вращения (мин <sup>-1</sup> )	Подача (мин.—макс.) (мм/об)
	<b>3.2</b>	8900	0.1 (0.11—0.16)	8900	0.15 (0.16—0.21)	8900	0.15 (0.16—0.21)
	<b>4.0</b>	7100	0.15 (0.13—0.20)	7100	0.2 (0.20—0.27)	7100	0.2 (0.20—0.27)
	<b>5.0</b>	5700	0.2 (0.17—0.25)	5700	0.25 (0.25—0.33)	5700	0.25 (0.25—0.33)
	<b>6.3</b>	6000	0.25 (0.21—0.32)	6000	0.35 (0.32—0.42)	6000	0.35 (0.32—0.42)
	<b>8.0</b>	4700	0.3 (0.27—0.40)	4700	0.45 (0.40—0.53)	4700	0.45 (0.40—0.53)
	<b>10.0</b>	3800	0.4 (0.33—0.50)	3800	0.55 (0.50—0.67)	3800	0.55 (0.50—0.67)
	<b>14.0</b>	4200	0.5 (0.40—0.60)	4200	0.7 (0.60—0.80)	4200	0.7 (0.60—0.80)

(Примечание 1) При сверлении отверстий с глубиной сверления свыше  $l/d=10$  рекомендуется сначала просверлить направляющее отверстие. (В противном случае возможна поломка сверла.)

(Примечание 2) Для предварительного сверления рекомендуются сверла Mitsubishi MNS, MAE-MB или MAS-MB.

### УКАЗАНИЯ ПО ЭКСПЛУАТАЦИИ СЕРИИ MNS (L/D 3, 5, 8)

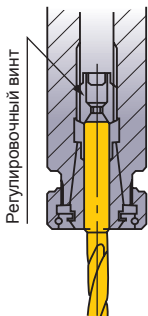
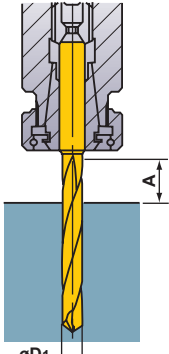
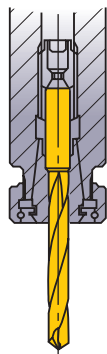
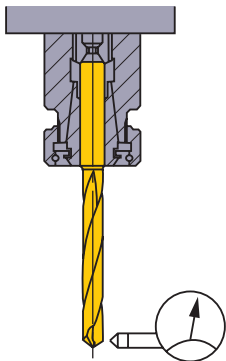
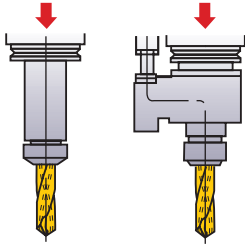
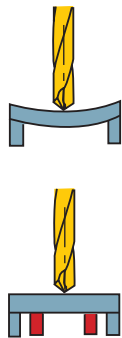
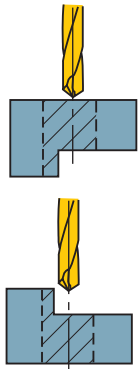
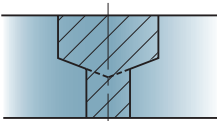
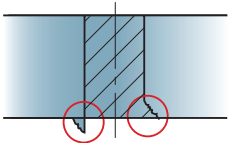
<p><b>Крепление сверла</b></p>  <p>Регулировочный винт</p> <p>Цанговый патрон с упорным подшипником надежно держит сверло.</p>	<p><b>Длина сверла</b></p>  <p><math>A : \geq D1 \times 1.5</math></p>	<p><b>Установка сверла</b></p>  <p>Не прижимать по режущей кромке.</p>	<p><b>Допуск на установку</b></p>  <p>Биение <math>\leq 0.03\text{мм}</math></p>
<p><b>Метод охлаждения (MNS)</b></p>  <p>Тип охлаждения через шпиндель    Тип охлаждения на вращающийся шпиндель станка</p> <p>Давление СОЖ приблизительно. 0.5—7МПа</p>	<p><b>Рекомендации по использованию СОЖ</b></p> <p>&lt;Тип MNS&gt;</p> <ol style="list-style-type: none"> <li>1) Рекомендуется регулярно проводить замену СОЖ во избежание забивания каналов в сверле.</li> <li>2) Для предотвращения забивания мелкой стружкой отверстий сверла используйте фильтр, как профилактическую меру. Для сверл малого диаметра рекомендуется применять фильтр с более мелкими отверстиями.</li> </ol>	<p><b>Тонкая заготовка</b></p>  <p>Если наблюдается отгиб.</p> <p>Необходима опора для заготовки.</p>	<p><b>Прерывистое резание</b></p>  <p>Один процесс</p> <p>① Уменьшить подачу при сверлении разомкнутой детали (при прерывистом сверлении).</p> <p>Требуется предварительная обработка.</p> <p>① До сверления предварительно подрезать торец концевой фрезой.</p>
<p><b>Ступенчатые отверстия.</b></p>  <ol style="list-style-type: none"> <li>① Разделите операцию на два перехода.</li> <li>② Сначала просверлите отверстие большего диаметра.</li> </ol> <p>*Инструменты для снятия фаски и цекования могут быть изготовлены по заказу.</p>	<p><b>Образование заусенцев и выкрашивание заготовки.</b></p>  <ol style="list-style-type: none"> <li>① На выходе сверла из отверстия снизьте подачу.</li> <li>② Снять фаску.</li> <li>③ Измените угол при вершине.</li> </ol>		

■ УКАЗАНИЯ ПО ЭКСПЛУАТАЦИИ ДЛИННОЙ СЕРИИ MNS (L/D 10, 12, 15, 20, 25, 30)

**СВЕРЛЕНИЕ НА ПЛОСКИХ ПОВЕРХНОСТЯХ** ● Сделать глухое отверстие

■ 1. Выполнить направляющее отверстие

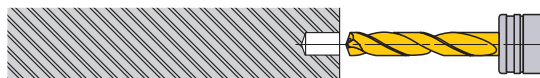

- ① Для выполнения направляющего отверстия мы рекомендуем использовать сверла фирмы Mitsubishi типа MNS, MAE-MB или MAS-MB.
- ② Используйте сверло такого же диаметра, как и для обработки глубоких отверстий.
- ③ Направляющее отверстие : мин. 1D или глубже  
(Выберите глубину направляющего отверстия, соответствующую длине сверхдлинного сверла.)

■ 2. Предварительная обработка при помощи длинного сверла.



- ① Вход в направляющее отверстие с малой частотой вращения.  
(Скорость резания 20—30 м/мин, подача 0.2—0.3 мм/об)
- ② Остановить сверло для глубоких отверстий 1—3 мм до достижения дна направляющего отверстия.

■ 3. сверление глубокого отверстия

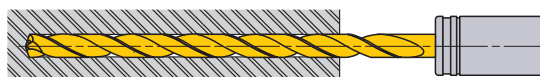

- ① Увеличьте частоту вращения и подачу за цикл и просверлите до желаемой глубины.

■ 4. Выведите сверло



- ① После просверливания, примерно на 1—2 мм до конца отверстия, уменьшить скорость резания (скорость резания 20—30 м/мин.)
- ② Выньте сверло примерно до глубины направляющего отверстия (Vf=3000мм/мин.)
- ③ Выведите сверло из направляющего отверстия с уменьшенной частотой вращения (n=300, Vf=3000мм/мин)

**СВЕРЛЕНИЕ НА НАКЛОННЫХ ПОВЕРХНОСТЯХ** ● Отверстия на изогнутых заготовках

■ 1. Плоское фрезерование



- ① Фрезеруйте плоскую поверхность в заготовке и установите фрезу с тем же диаметром, что и диаметр желаемого отверстия.

■ 2. Выполнить направляющее отверстие



- ① Для выполнения направляющего отверстия мы рекомендуем использовать сверла фирмы Mitsubishi типа MNS, MAE-MB или MAS-MB.
- ② Используйте сверло такого же диаметра, как и для обработки глубоких отверстий.
- ③ Направляющее отверстие : мин. 1D или глубже  
(Выберите глубину направляющего отверстия, соответствующую длине сверхдлинного сверла.)

■ 3. Предварительная обработка при помощи длинного сверла.

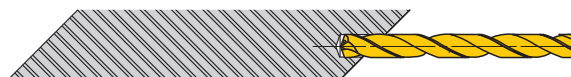

- ① Вход в направляющее отверстие с малой частотой вращения.  
(Скорость резания 20—30 м/мин, подача 0.2—0.3 мм/об)
- ② Остановить сверло для глубоких отверстий 1—3 мм до достижения дна направляющего отверстия.

■ 4. сверление глубокого отверстия



- ① Увеличьте частоту вращения и подачу за цикл и просверлите до желаемой глубины.

■ 5. Проходные отверстия

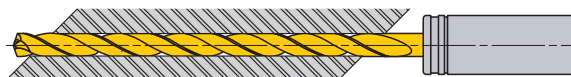

- ① При выходе из заготовки режущая кромка сверла может обломиться.
- ② Уменьшите подачу до Vf=0.05мм—0.1мм/об.

■ 6. Выведите сверло



- ① Поднимите сверло из направляющего отверстия до глубины начальной точки с подачей 3000мм/мин.
- ② Обработайте отверстие со скоростью резания 20—30м/мин и подачей 0.2—0.3мм/об.

# СВЕРЛЕНИЕ (МОНОЛИТНЫЕ ТВЕРДОСПЛАВНЫЕ СВЕРЛА)

## MAE, MAS

- Применяется для сверления алюминиевых сплавов и чугунов.
- Высокая точность получаемого отверстия.
- Предварительное сверление для накатки резьбы.
- Винтовые каналы для внутреннего охлаждения дают возможность использовать высокоскоростную обработку (сверла типа MAS).

Углеродистая сталь Легированная сталь	Закалённая сталь	Нержавеющая сталь	Чугун	Лёгкий сплав	Жаропрочные сплавы
			○	◎	

D1=3	3<D1≤6	6<D1≤10	10<D1≤16
+0.005 0	+0.005 0	+0.005 0	+0.005 0
0 -0.006	0 -0.008	0 -0.009	0 -0.011

**MAE** (Наружное охлаждение)

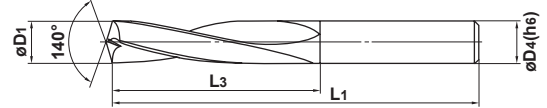

**MAS** (Внутреннее охлаждение)

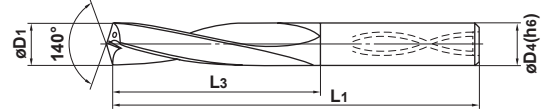

(Примечание 1) Сверла типа MAS диаметром более  $\phi 5.0$  мм имеют углубление на торце.  
(Примечание 2) Сверла MAE/MAS предназначены для использования с термоматрицами.

Диам. сверла D1 (мм)	Глубина сверления (l/d)	Охлаждение (Внут./Нар.)	Наличие HT10	Обозначение	Размеры (мм)		
					L3	L1	D4
3.0	3	Нар.	★	MAE0300MB	21	61	3
	3	Внут.	□	MAS0300MB	21	61	3
	6	Внут.	●	MAS0300LB	30	70	3
3.1	3	Нар.	★	MAE0310MB	24	64	4
	3	Внут.	□	MAS0310MB	24	64	4
	6	Внут.	★	MAS0310LB	34	74	4
3.2	3	Нар.	★	MAE0320MB	24	64	4
	3	Внут.	□	MAS0320MB	24	64	4
	6	Внут.	★	MAS0320LB	34	74	4
3.3	3	Нар.	★	MAE0330MB	24	64	4
	3	Внут.	□	MAS0330MB	24	64	4
	6	Внут.	●	MAS0330LB	34	74	4
3.4	3	Нар.	★	MAE0340MB	24	64	4
	3	Внут.	□	MAS0340MB	24	64	4
	6	Внут.	★	MAS0340LB	34	74	4
3.5	3	Нар.	★	MAE0350MB	24	64	4
	3	Внут.	□	MAS0350MB	24	64	4
	6	Внут.	●	MAS0350LB	34	74	4
3.6	3	Нар.	★	MAE0360MB	28	68	4
	3	Внут.	□	MAS0360MB	28	68	4
	6	Внут.	★	MAS0360LB	40	80	4
3.65	3	Нар.	★	* MAE0365MB	28	68	4
	3	Внут.	□	* MAS0365MB	28	68	4
	6	Внут.	●	* MAS0365LB	40	80	4
3.7	3	Нар.	★	MAE0370MB	28	68	4
	3	Внут.	□	MAS0370MB	28	68	4
	6	Внут.	★	MAS0370LB	40	80	4
3.8	3	Нар.	★	MAE0380MB	28	68	4
	3	Внут.	□	MAS0380MB	28	68	4
	6	Внут.	★	MAS0380LB	40	80	4
3.9	3	Нар.	★	MAE0390MB	28	68	4
	3	Внут.	□	MAS0390MB	28	68	4
	6	Внут.	★	MAS0390LB	40	80	4
4.0	3	Нар.	★	MAE0400MB	28	68	4
	3	Внут.	□	MAS0400MB	28	68	4
	6	Внут.	●	MAS0400LB	40	80	4
4.1	3	Нар.	★	MAE0410MB	31	71	5
	3	Внут.	□	MAS0410MB	31	71	5
	6	Внут.	★	MAS0410LB	44	84	5

Диам. сверла D1 (мм)	Глубина сверления (l/d)	Охлаждение (Внут./Нар.)	Наличие HT10	Обозначение	Размеры (мм)		
					L3	L1	D4
4.2	3	Нар.	★	MAE0420MB	31	71	5
	3	Внут.	□	MAS0420MB	31	71	5
	6	Внут.	●	MAS0420LB	44	84	5
4.3	3	Нар.	★	MAE0430MB	31	71	5
	3	Внут.	□	MAS0430MB	31	71	5
	6	Внут.	★	MAS0430LB	44	84	5
4.4	3	Нар.	★	MAE0440MB	31	71	5
	3	Внут.	□	MAS0440MB	31	71	5
	6	Внут.	★	MAS0440LB	44	84	5
4.5	3	Нар.	★	MAE0450MB	31	71	5
	3	Внут.	□	MAS0450MB	31	71	5
	6	Внут.	★	MAS0450LB	44	84	5
4.6	3	Нар.	★	* MAE0460MB	33	73	5
	3	Внут.	□	* MAS0460MB	33	73	5
	6	Внут.	●	* MAS0460LB	48	88	5
4.7	3	Нар.	★	MAE0470MB	33	73	5
	3	Внут.	□	MAS0470MB	33	73	5
	6	Внут.	★	MAS0470LB	48	88	5
4.8	3	Нар.	★	MAE0480MB	33	73	5
	3	Внут.	□	MAS0480MB	33	73	5
	6	Внут.	★	MAS0480LB	48	88	5
4.9	3	Нар.	★	MAE0490MB	33	73	5
	3	Внут.	□	MAS0490MB	33	73	5
	6	Внут.	★	MAS0490LB	48	88	5
5.0	3	Нар.	★	MAE0500MB	33	73	5
	3	Внут.	●	MAS0500MB	33	73	5
	6	Внут.	●	MAS0500LB	48	88	5
5.1	3	Нар.	★	MAE0510MB	36	76	6
	3	Внут.	□	MAS0510MB	36	76	6
	6	Внут.	★	MAS0510LB	52	92	6
5.2	3	Нар.	★	MAE0520MB	36	76	6
	3	Внут.	□	MAS0520MB	36	76	6
	6	Внут.	●	MAS0520LB	52	92	6
5.3	3	Нар.	★	MAE0530MB	36	76	6
	3	Внут.	□	MAS0530MB	36	76	6
	6	Внут.	★	MAS0530LB	52	92	6
5.4	3	Нар.	★	MAE0540MB	36	76	6
	3	Внут.	□	MAS0540MB	36	76	6
	6	Внут.	★	MAS0540LB	52	92	6

\* : Стандартные размеры отверстий для резьбонакатных метчиков.

● : Есть на складе. ★ : Со склада в Японии.

□ : Нет на складе, выпускается исключительно под заказ.

L096

Диам. сверла D1 (мм)	Глубина сверления (l/d)	Охлаждение (Внут./Нар.)	Наличие НТ110	Обозначение	Размеры (мм)		
					L3	L1	D4
5.5	3	Нар.	★	* MAE0550MB	36	76	6
	3	Внут.	★	* MAS0550MB	36	76	6
	6	Внут.	●	* MAS0550LB	52	92	6
5.6	3	Нар.	★	MAE0560MB	39	79	6
	3	Внут.	□	MAS0560MB	39	79	6
	6	Внут.	★	MAS0560LB	57	97	6
5.7	3	Нар.	★	MAE0570MB	39	79	6
	3	Внут.	□	MAS0570MB	39	79	6
	6	Внут.	★	MAS0570LB	57	97	6
5.8	3	Нар.	★	MAE0580MB	39	79	6
	3	Внут.	□	MAS0580MB	39	79	6
	6	Внут.	★	MAS0580LB	57	97	6
5.9	3	Нар.	★	MAE0590MB	39	79	6
	3	Внут.	□	MAS0590MB	39	79	6
	6	Внут.	★	MAS0590LB	57	97	6
6.0	3	Нар.	★	MAE0600MB	39	79	6
	3	Внут.	●	MAS0600MB	39	79	6
	6	Внут.	●	MAS0600LB	57	97	6
6.1	3	Нар.	★	MAE0610MB	42	84	7
	3	Внут.	□	MAS0610MB	42	84	7
	6	Внут.	★	MAS0610LB	62	104	7
6.2	3	Нар.	★	MAE0620MB	42	84	7
	3	Внут.	□	MAS0620MB	42	84	7
	6	Внут.	★	MAS0620LB	62	104	7
6.3	3	Нар.	★	MAE0630MB	42	84	7
	3	Внут.	□	MAS0630MB	42	84	7
	6	Внут.	★	MAS0630LB	62	104	7
6.4	3	Нар.	★	MAE0640MB	42	84	7
	3	Внут.	□	MAS0640MB	42	84	7
	6	Внут.	★	MAS0640LB	62	104	7
6.5	3	Нар.	★	MAE0650MB	42	84	7
	3	Внут.	★	MAS0650MB	42	84	7
	6	Внут.	●	MAS0650LB	62	104	7
6.6	3	Нар.	★	MAE0660MB	42	84	7
	3	Внут.	□	MAS0660MB	42	84	7
	6	Внут.	★	MAS0660LB	65	107	7
6.7	3	Нар.	★	MAE0670MB	42	84	7
	3	Внут.	□	MAS0670MB	42	84	7
	6	Внут.	●	MAS0670LB	65	107	7
6.8	3	Нар.	★	MAE0680MB	42	84	7
	3	Внут.	★	MAS0680MB	42	84	7
	6	Внут.	●	MAS0680LB	65	107	7
6.9	3	Нар.	★	MAE0690MB	42	84	7
	3	Внут.	□	MAS0690MB	42	84	7
	6	Внут.	★	MAS0690LB	65	107	7
7.0	3	Нар.	★	MAE0700MB	42	84	7
	3	Внут.	★	MAS0700MB	42	84	7
	6	Внут.	●	MAS0700LB	65	107	7

Диам. сверла D1 (мм)	Глубина сверления (l/d)	Охлаждение (Внут./Нар.)	Наличие НТ110	Обозначение	Размеры (мм)		
					L3	L1	D4
7.1	3	Нар.	★	MAE0710MB	48	90	8
	3	Внут.	□	MAS0710MB	48	90	8
	6	Внут.	★	MAS0710LB	68	110	8
7.2	3	Нар.	★	MAE0720MB	48	90	8
	3	Внут.	□	MAS0720MB	48	90	8
	6	Внут.	★	MAS0720LB	68	110	8
7.3	3	Нар.	★	MAE0730MB	48	90	8
	3	Внут.	□	MAS0730MB	48	90	8
	6	Внут.	★	MAS0730LB	68	110	8
7.35	3	Нар.	★	* MAE0735MB	48	90	8
	3	Внут.	★	* MAS0735MB	48	90	8
	6	Внут.	●	* MAS0735LB	68	110	8
7.4	3	Нар.	★	MAE0740MB	48	90	8
	3	Внут.	□	MAS0740MB	48	90	8
	6	Внут.	★	MAS0740LB	68	110	8
7.5	3	Нар.	★	MAE0750MB	48	90	8
	3	Внут.	□	MAS0750MB	48	90	8
	6	Внут.	★	MAS0750LB	68	110	8
7.6	3	Нар.	★	MAE0760MB	48	90	8
	3	Внут.	□	MAS0760MB	48	90	8
	6	Внут.	★	MAS0760LB	72	114	8
7.7	3	Нар.	★	MAE0770MB	48	90	8
	3	Внут.	□	MAS0770MB	48	90	8
	6	Внут.	★	MAS0770LB	72	114	8
7.8	3	Нар.	★	MAE0780MB	48	90	8
	3	Внут.	□	MAS0780MB	48	90	8
	6	Внут.	★	MAS0780LB	72	114	8
7.9	3	Нар.	★	MAE0790MB	48	90	8
	3	Внут.	□	MAS0790MB	48	90	8
	6	Внут.	★	MAS0790LB	72	114	8
8.0	3	Нар.	★	MAE0800MB	48	90	8
	3	Внут.	●	MAS0800MB	48	90	8
	6	Внут.	●	MAS0800LB	72	114	8
8.1	3	Нар.	★	MAE0810MB	50	94	9
	3	Внут.	□	MAS0810MB	50	94	9
	6	Внут.	★	MAS0810LB	75	119	9
8.2	3	Нар.	★	MAE0820MB	50	94	9
	3	Внут.	□	MAS0820MB	50	94	9
	6	Внут.	★	MAS0820LB	75	119	9
8.3	3	Нар.	★	MAE0830MB	50	94	9
	3	Внут.	□	MAS0830MB	50	94	9
	6	Внут.	★	MAS0830LB	75	119	9
8.4	3	Нар.	★	MAE0840MB	50	94	9
	3	Внут.	□	MAS0840MB	50	94	9
	6	Внут.	★	MAS0840LB	75	119	9
8.5	3	Нар.	★	MAE0850MB	50	94	9
	3	Внут.	●	MAS0850MB	50	94	9
	6	Внут.	★	MAS0850LB	75	119	9

\* : Стандартные размеры отверстий для резьбонакатных метчиков.

# СВЕРЛЕНИЕ (МОНОЛИТНЫЕ ТВЕРДОСПЛАВНЫЕ СВЕРЛА)

## MAE, MAS

ТВЕРДЫЙ  
СПЛАВ

Диам. сверла D1 (мм)	Глубина сверления (l/d)	Охлаждение (Внут./Нар.)	Наличие HT110	Обозначение	Размеры (мм)		
					L3	L1	D4
8.6	3	Нар.	★	MAE0860MB	50	94	9
	3	Внут.	□	MAS0860MB	50	94	9
	6	Внут.	★	MAS0860LB	77	121	9
8.7	3	Нар.	★	MAE0870MB	50	94	9
	3	Внут.	□	MAS0870MB	50	94	9
	6	Внут.	★	MAS0870LB	77	121	9
8.8	3	Нар.	★	MAE0880MB	50	94	9
	3	Внут.	□	MAS0880MB	50	94	9
	6	Внут.	★	MAS0880LB	77	121	9
8.9	3	Нар.	★	MAE0890MB	50	94	9
	3	Внут.	□	MAS0890MB	50	94	9
	6	Внут.	★	MAS0890LB	77	121	9
9.0	3	Нар.	★	MAE0900MB	50	94	9
	3	Внут.	★	MAS0900MB	50	94	9
	6	Внут.	●	MAS0900LB	77	121	9
9.1	3	Нар.	★	MAE0910MB	53	97	10
	3	Внут.	□	MAS0910MB	53	97	10
	6	Внут.	★	MAS0910LB	81	125	10
9.2	3	Нар.	★	MAE0920MB	53	97	10
	3	Внут.	□	MAS0920MB	53	97	10
	6	Внут.	★	MAS0920LB	81	125	10
9.21	3	Нар.	★	* MAE0921MB	53	97	10
	3	Внут.	★	* MAS0921MB	53	97	10
	6	Внут.	★	* MAS0921LB	81	125	10
9.3	3	Нар.	★	MAE0930MB	53	97	10
	3	Внут.	□	MAS0930MB	53	97	10
	6	Внут.	★	MAS0930LB	81	125	10
9.4	3	Нар.	★	MAE0940MB	53	97	10
	3	Внут.	□	MAS0940MB	53	97	10
	6	Внут.	★	MAS0940LB	81	125	10
9.5	3	Нар.	★	MAE0950MB	53	97	10
	3	Внут.	★	MAS0950MB	53	97	10
	6	Внут.	●	MAS0950LB	81	125	10
9.6	3	Нар.	★	MAE0960MB	53	97	10
	3	Внут.	□	MAS0960MB	53	97	10
	6	Внут.	★	MAS0960LB	81	125	10
9.7	3	Нар.	★	MAE0970MB	53	97	10
	3	Внут.	□	MAS0970MB	53	97	10
	6	Внут.	★	MAS0970LB	81	125	10
9.8	3	Нар.	★	MAE0980MB	53	97	10
	3	Внут.	□	MAS0980MB	53	97	10
	6	Внут.	★	MAS0980LB	81	125	10
9.9	3	Нар.	★	MAE0990MB	53	97	10
	3	Внут.	□	MAS0990MB	53	97	10
	6	Внут.	★	MAS0990LB	81	125	10
10.0	3	Нар.	★	MAE1000MB	53	97	10
	3	Внут.	●	MAS1000MB	53	97	10
	6	Внут.	●	MAS1000LB	81	125	10

Диам. сверла D1 (мм)	Глубина сверления (l/d)	Охлаждение (Внут./Нар.)	Наличие HT110	Обозначение	Размеры (мм)		
					L3	L1	D4
10.1	3	Нар.	□	MAE1010MB	55	101	11
	3	Внут.	□	MAS1010MB	55	101	11
	6	Внут.	□	MAS1010LB	89	135	11
10.2	3	Нар.	□	MAE1020MB	55	101	11
	3	Внут.	□	MAS1020MB	55	101	11
	6	Внут.	□	MAS1020LB	89	135	11
10.3	3	Нар.	★	MAE1030MB	55	101	11
	3	Внут.	★	MAS1030MB	55	101	11
	6	Внут.	●	MAS1030LB	89	135	11
10.4	3	Нар.	□	MAE1040MB	55	101	11
	3	Внут.	□	MAS1040MB	55	101	11
	6	Внут.	□	MAS1040LB	89	135	11
10.5	3	Нар.	★	MAE1050MB	55	101	11
	3	Внут.	★	MAS1050MB	55	101	11
	6	Внут.	●	MAS1050LB	89	135	11
10.6	3	Нар.	□	MAE1060MB	55	101	11
	3	Внут.	□	MAS1060MB	55	101	11
	6	Внут.	□	MAS1060LB	89	135	11
10.7	3	Нар.	□	MAE1070MB	55	101	11
	3	Внут.	□	MAS1070MB	55	101	11
	6	Внут.	□	MAS1070LB	89	135	11
10.8	3	Нар.	□	MAE1080MB	55	101	11
	3	Внут.	□	MAS1080MB	55	101	11
	6	Внут.	□	MAS1080LB	89	135	11
10.9	3	Нар.	□	MAE1090MB	55	101	11
	3	Внут.	□	MAS1090MB	55	101	11
	6	Внут.	□	MAS1090LB	89	135	11
11.0	3	Нар.	★	MAE1100MB	55	101	11
	3	Внут.	★	MAS1100MB	55	101	11
	6	Внут.	●	MAS1100LB	89	135	11
11.08	3	Нар.	★	* MAE1108MB	60	106	12
	3	Внут.	★	* MAS1108MB	60	106	12
	6	Внут.	●	* MAS1108LB	94	140	12
11.1	3	Нар.	□	MAE1110MB	60	106	12
	3	Внут.	□	MAS1110MB	60	106	12
	6	Внут.	□	MAS1110LB	94	140	12
11.2	3	Нар.	□	MAE1120MB	60	106	12
	3	Внут.	□	MAS1120MB	60	106	12
	6	Внут.	□	MAS1120LB	94	140	12
11.3	3	Нар.	□	MAE1130MB	60	106	12
	3	Внут.	□	MAS1130MB	60	106	12
	6	Внут.	□	MAS1130LB	94	140	12
11.4	3	Нар.	□	MAE1140MB	60	106	12
	3	Внут.	□	MAS1140MB	60	106	12
	6	Внут.	□	MAS1140LB	94	140	12
11.5	3	Нар.	□	MAE1150MB	60	106	12
	3	Внут.	□	MAS1150MB	60	106	12
	6	Внут.	□	MAS1150LB	94	140	12

\* : Стандартные размеры отверстий для резьбонакатных метчиков.

● : Есть на складе. ★ : Со склада в Японии.

□ : Нет на складе, выпускается исключительно под заказ.

L098

Заказ инструмента: <http://steelcam.org> | 8 (343) 382-52-03 | [sales@sverla-ekb.ru](mailto:sales@sverla-ekb.ru)

Диам. сверла D1 (мм)	Глубина сверления (l/d)	Охлаждение (Внут./Нар.)	Наличие НТ110	Обозначение	Размеры (мм)		
					L3	L1	D4
11.6	3	Нар.	□	MAE1160MB	60	106	12
	3	Внут.	□	MAS1160MB	60	106	12
	6	Внут.	□	MAS1160LB	94	140	12
11.7	3	Нар.	□	MAE1170MB	60	106	12
	3	Внут.	□	MAS1170MB	60	106	12
	6	Внут.	□	MAS1170LB	94	140	12
11.8	3	Нар.	□	MAE1180MB	60	106	12
	3	Внут.	□	MAS1180MB	60	106	12
	6	Внут.	□	MAS1180LB	94	140	12
11.9	3	Нар.	□	MAE1190MB	60	106	12
	3	Внут.	□	MAS1190MB	60	106	12
	6	Внут.	□	MAS1190LB	94	140	12
12.0	3	Нар.	★	MAE1200MB	60	106	12
	3	Внут.	●	MAS1200MB	60	106	12
	6	Внут.	●	MAS1200LB	94	140	12
12.1	3	Нар.	□	MAE1210MB	65	115	13
	3	Внут.	□	MAS1210MB	65	115	13
	6	Внут.	□	MAS1210LB	100	150	13
12.2	3	Нар.	□	MAE1220MB	65	115	13
	3	Внут.	□	MAS1220MB	65	115	13
	6	Внут.	□	MAS1220LB	100	150	13
12.3	3	Нар.	□	MAE1230MB	65	115	13
	3	Внут.	□	MAS1230MB	65	115	13
	6	Внут.	□	MAS1230LB	100	150	13
12.4	3	Нар.	□	MAE1240MB	65	115	13
	3	Внут.	□	MAS1240MB	65	115	13
	6	Внут.	□	MAS1240LB	100	150	13
12.5	3	Нар.	★	MAE1250MB	65	115	13
	3	Внут.	●	MAS1250MB	65	115	13
	6	Внут.	●	MAS1250LB	100	150	13
12.6	3	Нар.	□	MAE1260MB	65	115	13
	3	Внут.	□	MAS1260MB	65	115	13
	6	Внут.	□	MAS1260LB	100	150	13
12.7	3	Нар.	□	MAE1270MB	65	115	13
	3	Внут.	□	MAS1270MB	65	115	13
	6	Внут.	□	MAS1270LB	100	150	13
12.8	3	Нар.	□	MAE1280MB	65	115	13
	3	Внут.	□	MAS1280MB	65	115	13
	6	Внут.	□	MAS1280LB	100	150	13
12.9	3	Нар.	□	MAE1290MB	65	115	13
	3	Внут.	□	MAS1290MB	65	115	13
	6	Внут.	□	MAS1290LB	100	150	13
12.96	3	Нар.	★	* MAE1296MB	65	115	13
	3	Внут.	★	* MAS1296MB	65	115	13
	6	Внут.	★	* MAS1296LB	100	150	13
13.0	3	Нар.	★	MAE1300MB	65	115	13
	3	Внут.	★	MAS1300MB	65	115	13
	6	Внут.	●	MAS1300LB	100	150	13

\* : Стандартные размеры отверстий для резьбонакатных метчиков.

Диам. сверла D1 (мм)	Глубина сверления (l/d)	Охлаждение (Внут./Нар.)	Наличие НТ110	Обозначение	Размеры (мм)		
					L3	L1	D4
13.1	3	Нар.	□	MAE1310MB	70	120	14
	3	Внут.	□	MAS1310MB	70	120	14
	6	Внут.	□	MAS1310LB	110	160	14
13.2	3	Нар.	□	MAE1320MB	70	120	14
	3	Внут.	□	MAS1320MB	70	120	14
	6	Внут.	□	MAS1320LB	110	160	14
13.3	3	Нар.	□	MAE1330MB	70	120	14
	3	Внут.	□	MAS1330MB	70	120	14
	6	Внут.	□	MAS1330LB	110	160	14
13.4	3	Нар.	□	MAE1340MB	70	120	14
	3	Внут.	□	MAS1340MB	70	120	14
	6	Внут.	□	MAS1340LB	110	160	14
13.5	3	Нар.	★	MAE1350MB	70	120	14
	3	Внут.	★	MAS1350MB	70	120	14
	6	Внут.	★	MAS1350LB	110	160	14
13.6	3	Нар.	□	MAE1360MB	70	120	14
	3	Внут.	□	MAS1360MB	70	120	14
	6	Внут.	□	MAS1360LB	110	160	14
13.7	3	Нар.	□	MAE1370MB	70	120	14
	3	Внут.	□	MAS1370MB	70	120	14
	6	Внут.	□	MAS1370LB	110	160	14
13.8	3	Нар.	□	MAE1380MB	70	120	14
	3	Внут.	□	MAS1380MB	70	120	14
	6	Внут.	□	MAS1380LB	110	160	14
13.9	3	Нар.	□	MAE1390MB	70	120	14
	3	Внут.	□	MAS1390MB	70	120	14
	6	Внут.	□	MAS1390LB	110	160	14
14.0	3	Нар.	★	MAE1400MB	70	120	14
	3	Внут.	●	MAS1400MB	70	120	14
	6	Внут.	●	MAS1400LB	110	160	14
14.1	3	Нар.	□	MAE1410MB	72	130	15
	3	Внут.	□	MAS1410MB	72	130	15
	6	Внут.	□	MAS1410LB	115	173	15
14.2	3	Нар.	□	MAE1420MB	72	130	15
	3	Внут.	□	MAS1420MB	72	130	15
	6	Внут.	□	MAS1420LB	115	173	15
14.3	3	Нар.	□	MAE1430MB	72	130	15
	3	Внут.	□	MAS1430MB	72	130	15
	6	Внут.	□	MAS1430LB	115	173	15
14.4	3	Нар.	□	MAE1440MB	72	130	15
	3	Внут.	□	MAS1440MB	72	130	15
	6	Внут.	□	MAS1440LB	115	173	15
14.5	3	Нар.	□	MAE1450MB	72	130	15
	3	Внут.	□	MAS1450MB	72	130	15
	6	Внут.	□	MAS1450LB	115	173	15
14.6	3	Нар.	□	MAE1460MB	72	130	15
	3	Внут.	□	MAS1460MB	72	130	15
	6	Внут.	□	MAS1460LB	115	173	15

Диам. сверла D1 (мм)	Глубина сверления (l/d)	Охлаждение (Внут./Нар.)	Наличие HT110	Обозначение	Размеры (мм)		
					L3	L1	D4
14.7	3	Нар.	<input type="checkbox"/>	MAE1470MB	72	130	15
	3	Внут.	<input type="checkbox"/>	MAS1470MB	72	130	15
	6	Внут.	<input type="checkbox"/>	MAS1470LB	115	173	15
14.8	3	Нар.	<input type="checkbox"/>	MAE1480MB	72	130	15
	3	Внут.	<input type="checkbox"/>	MAS1480MB	72	130	15
	6	Внут.	<input type="checkbox"/>	MAS1480LB	115	173	15
14.9	3	Нар.	<input type="checkbox"/>	MAE1490MB	72	130	15
	3	Внут.	<input type="checkbox"/>	MAS1490MB	72	130	15
	6	Внут.	<input type="checkbox"/>	MAS1490LB	115	173	15
14.96	3	Нар.	★	* MAE1496MB	72	130	15
	3	Внут.	★	* MAS1496MB	72	130	15
	6	Внут.	★	* MAS1496LB	115	173	15
15.0	3	Нар.	★	MAE1500MB	72	130	15
	3	Внут.	★	MAS1500MB	72	130	15
	6	Внут.	●	MAS1500LB	115	173	15
15.1	3	Нар.	<input type="checkbox"/>	MAE1510MB	76	134	16
	3	Внут.	<input type="checkbox"/>	MAS1510MB	76	134	16
	6	Внут.	<input type="checkbox"/>	MAS1510LB	120	178	16
15.2	3	Нар.	<input type="checkbox"/>	MAE1520MB	76	134	16
	3	Внут.	<input type="checkbox"/>	MAS1520MB	76	134	16
	6	Внут.	<input type="checkbox"/>	MAS1520LB	120	178	16
15.3	3	Нар.	<input type="checkbox"/>	MAE1530MB	76	134	16
	3	Внут.	<input type="checkbox"/>	MAS1530MB	76	134	16
	6	Внут.	<input type="checkbox"/>	MAS1530LB	120	178	16
15.4	3	Нар.	<input type="checkbox"/>	MAE1540MB	76	134	16
	3	Внут.	<input type="checkbox"/>	MAS1540MB	76	134	16
	6	Внут.	<input type="checkbox"/>	MAS1540LB	120	178	16
15.5	3	Нар.	<input type="checkbox"/>	MAE1550MB	76	134	16
	3	Внут.	<input type="checkbox"/>	MAS1550MB	76	134	16
	6	Внут.	<input type="checkbox"/>	MAS1550LB	120	178	16
15.6	3	Нар.	<input type="checkbox"/>	MAE1560MB	76	134	16
	3	Внут.	<input type="checkbox"/>	MAS1560MB	76	134	16
	6	Внут.	<input type="checkbox"/>	MAS1560LB	120	178	16
15.7	3	Нар.	<input type="checkbox"/>	MAE1570MB	76	134	16
	3	Внут.	<input type="checkbox"/>	MAS1570MB	76	134	16
	6	Внут.	<input type="checkbox"/>	MAS1570LB	120	178	16
15.8	3	Нар.	<input type="checkbox"/>	MAE1580MB	76	134	16
	3	Внут.	<input type="checkbox"/>	MAS1580MB	76	134	16
	6	Внут.	<input type="checkbox"/>	MAS1580LB	120	178	16
15.9	3	Нар.	<input type="checkbox"/>	MAE1590MB	76	134	16
	3	Внут.	<input type="checkbox"/>	MAS1590MB	76	134	16
	6	Внут.	<input type="checkbox"/>	MAS1590LB	120	178	16
16.0	3	Нар.	★	MAE1600MB	76	134	16
	3	Внут.	★	MAS1600MB	76	134	16
	6	Внут.	●	MAS1600LB	120	178	16

\* : Стандартные размеры отверстий для резьбонакатных метчиков.

● : Есть на складе. ★ : Со склада в Японии.

□ : Нет на складе, выпускается исключительно под заказ.

## РЕКОМЕНДУЕМЫЕ РЕЖИМЫ РЕЗАНИЯ

Тип	Обрабатываемый материал	Диам. сверла $\phi 3.0 - \phi 6.0$		Диам. сверла $\phi 6.1 - \phi 10.0$		Диам. сверла $\phi 10.1 - \phi 16.0$	
		Скорость резания (м/мин)	Подача (мм/об)	Скорость резания (м/мин)	Подача (мм/об)	Скорость резания (м/мин)	Подача (мм/об)
МАЕ	<b>N</b> Алюминиевые сплавы	90 (40–140)	0.15 (0.05–0.3)	100 (50–150)	0.2 (0.1–0.3)	120 (60–170)	0.25 (0.1–0.4)
	Алюминиевое литье	100 (60–150)	0.12 (0.05–0.25)	110 (70–160)	0.15 (0.05–0.25)	130 (80–180)	0.2 (0.1–0.3)
	<b>K</b> Серый чугун	40 (20–60)	0.15 (0.1–0.2)	60 (40–80)	0.2 (0.1–0.3)	80 (60–100)	0.3 (0.2–0.4)
	Ковкий чугун	30 (20–40)	0.1 (0.05–0.15)	40 (20–60)	0.12 (0.05–0.2)	60 (40–80)	0.2 (0.1–0.3)
МАС	<b>N</b> Алюминиевые сплавы	100 (60–150)	0.15 (0.05–0.3)	120 (80–170)	0.2 (0.1–0.3)	150 (100–200)	0.25 (0.1–0.4)
	Алюминиевое литье	120 (80–170)	0.12 (0.05–0.25)	150 (100–180)	0.15 (0.05–0.25)	160 (120–200)	0.2 (0.1–0.3)
	<b>K</b> Серый чугун	60 (40–80)	0.15 (0.1–0.2)	80 (60–110)	0.2 (0.1–0.3)	100 (70–130)	0.3 (0.2–0.4)
	Ковкий чугун	45 (30–60)	0.1 (0.05–0.15)	60 (40–80)	0.12 (0.05–0.2)	80 (60–100)	0.2 (0.1–0.3)

## ДИАМЕТРЫ ОТВЕРСТИЙ И СВЕРЛ ДЛЯ НАРЕЗАНИЯ РЕЗЬБЫ

Диаметр и шаг резьбы	Нарезание резьбы			Накатка резьбы		
	Диаметр сверла ( $\phi D_1$ )	Диаметр отверстия		Диаметр сверла ( $\phi D_1$ )	Диаметр отверстия	
		макс.	мин.		макс.	мин.
<b>M4x0.7</b>	<b>3.3</b>	3.242	3.422	<b>3.65</b>	3.65	3.70
<b>M5x0.8</b>	<b>4.2</b>	4.134	4.334	<b>4.60</b>	4.59	4.66
<b>M6x1.0</b>	<b>5.0</b>	4.917	5.153	<b>5.50</b>	5.48	5.57
<b>M8x1.25</b>	<b>6.8</b>	6.647	6.912	<b>7.35</b>	7.34	7.41
<b>M10x1.5</b>	<b>8.5</b>	8.376	8.676	<b>9.21</b>	9.18	9.28
<b>M12x1.75</b>	<b>10.3</b>	10.106	10.441	<b>11.08</b>	11.05	11.15
<b>M14x2</b>	<b>12.0</b>	11.835	12.210	<b>12.96</b>	12.92	13.04
<b>M16x2</b>	<b>14.0</b>	13.835	14.210	<b>14.96</b>	14.92	15.04

# СВЕРЛЕНИЕ (МОНОЛИТНЫЕ ТВЕРДОСПЛАВНЫЕ СВЕРЛА)

## MHS

- Высокое сопротивление продольному изгибу и уникальная двойная кромка.
- Сверление без периодического вывода сверла и длительный срок службы инструмента для сверления стали с высокой твердостью, 35HRC-55HRC

Углеродистая сталь Легированная сталь	Закалённая сталь	Нержавеющая сталь	Чугун	Лёгкий сплав	Жаропрочные сплавы
○	◎	○			○

	D1≤3	3<D1≤6	6<D1≤10	10<D1≤12
	+0.010 -0.002	+0.010 -0.002	+0.010 -0.005	+0.010 -0.008
	0 -0.006	0 -0.008	0 -0.009	0 -0.011

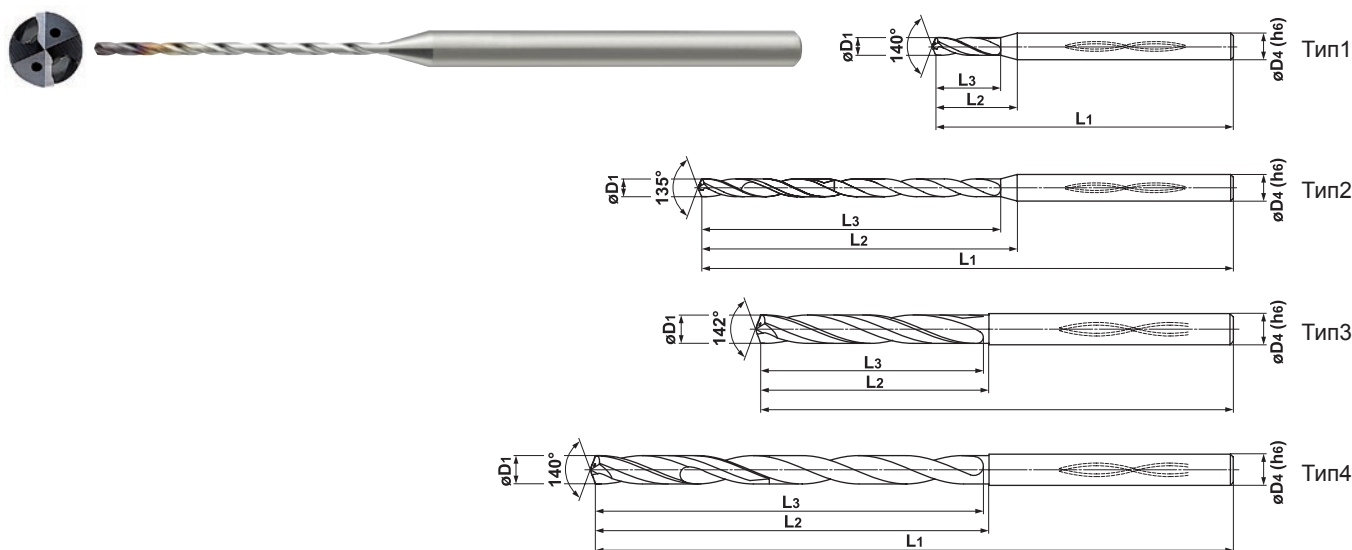

(Примечание 1) Сверла MHS предназначены для использования с термоматрицами.

(Примечание 2) Используйте самое короткое сверло такого же диаметра для сверления направляющего отверстия.

Диам. сверла D1 (мм)	Глубина сверления (l/d)	Охлаждение (Внут./Нар.)	Наличие VP-15TF	Обозначение	Размеры (мм)				Тип
					L3	L2	L1	D4	
0.95	3	Внут.	★	MHS0095L006B	6	9.8	60	3	1
	6	Внут.	★	0095L009B	9	12.8	60	3	2
	13	Внут.	★	0095L015B	15	18.8	60	3	2
	23	Внут.	★	0095L025B	25	28.8	60	3	2
	30	Внут.	★	0095L035B	35	38.8	80	3	2
1.00	3	Внут.	●	0100L006B	6	9.7	60	3	1
	6	Внут.	●	0100L009B	9	12.7	60	3	2
	12	Внут.	★	0100L015B	15	18.7	60	3	2
	22	Внут.	●	0100L025B	25	28.7	60	3	2
	30	Внут.	●	0100L035B	35	38.7	80	3	2
1.10	2	Внут.	●	0110L006B	6	9.5	60	3	1
	5	Внут.	★	0110L009B	9	12.5	60	3	2
	11	Внут.	●	0110L015B	15	18.5	60	3	2
	20	Внут.	●	0110L025B	25	28.5	60	3	2
	29	Внут.	●	0110L035B	35	38.5	80	3	2
1.20	2	Внут.	●	0120L006B	6	9.4	60	3	1
	5	Внут.	★	0120L009B	9	12.4	60	3	2
	10	Внут.	●	0120L015B	15	18.4	60	3	2
	18	Внут.	●	0120L025B	25	28.4	60	3	2
	26	Внут.	●	0120L035B	35	38.4	80	3	2
1.30	2	Внут.	●	0130L007B	7	10.2	60	3	1
	5	Внут.	★	0130L011B	11	14.2	60	3	2
	12	Внут.	●	0130L020B	20	23.2	60	3	2
	20	Внут.	●	0130L030B	30	33.2	80	3	2
	30	Внут.	●	0130L045B	45	48.2	80	3	2

Диам. сверла D1 (мм)	Глубина сверления (l/d)	Охлаждение (Внут./Нар.)	Наличие VP-15TF	Обозначение	Размеры (мм)				Тип
					L3	L2	L1	D4	
1.40	2	Внут.	●	MHS0140L007B	7	10.0	60	3	1
	5	Внут.	★	0140L011B	11	14.0	60	3	2
	11	Внут.	●	0140L020B	20	23.0	60	3	2
	18	Внут.	●	0140L030B	30	33.0	80	3	2
	29	Внут.	●	0140L045B	45	48.0	80	3	2
1.45	3	Внут.	●	0145L008B	8	10.9	60	3	1
	6	Внут.	★	0145L013B	13	15.9	60	3	2
	11	Внут.	★	0145L020B	20	22.9	60	3	2
	21	Внут.	●	0145L035B	35	37.9	80	3	2
	30	Внут.	★	0145L055B	55	57.9	100	3	2
1.50	2	Внут.	●	0150L008B	8	10.8	60	3	1
	6	Внут.	★	0150L013B	13	15.8	60	3	2
	10	Внут.	●	0150L020B	20	22.8	60	3	2
	20	Внут.	●	0150L035B	35	37.8	80	3	2
	30	Внут.	●	0150L055B	55	57.8	100	3	2
1.60	2	Внут.	●	0160L008B	8	10.6	60	3	1
	5	Внут.	★	0160L013B	13	15.6	60	3	2
	10	Внут.	●	0160L020B	20	22.6	60	3	2
	19	Внут.	●	0160L035B	35	37.6	80	3	2
	30	Внут.	●	0160L055B	55	57.6	100	3	2
1.70	2	Внут.	●	0170L008B	8	10.4	60	3	1
	5	Внут.	★	0170L013B	13	15.4	60	3	2
	9	Внут.	●	0170L020B	20	22.4	60	3	2
	18	Внут.	●	0170L035B	35	37.4	80	3	2
	29	Внут.	●	0170L055B	55	57.4	100	3	2

(Примечание) Пожалуйста, свяжитесь с нами если Вы не нашли нужную геометрию в данном каталоге (могут быть заказаны другие диаметры и длины).

● : Есть на складе. ★ : Со склада в Японии.

□ : Нет на складе, выпускается исключительно под заказ.

Диам. сверла D1 (мм)	Глубина сверления (l/d)	Охлаждение (Внут./Нар.)	Наличие VP15TF	Обозначение	Размеры (мм)				Тип
					L3	L2	L1	D4	
NEW	3	Внут.	●	MHS0180L010B	10	12.2	60	3	1
1.80	5	Внут.	★	0180L015B	15	17.2	60	3	2
	11	Внут.	●	0180L025B	25	27.2	60	3	2
	22	Внут.	●	0180L045B	45	47.2	80	3	2
	30	Внут.	●	0180L065B	65	67.2	100	3	2
NEW	2	Внут.	●	0190L010B	10	12.1	60	3	1
1.90	5	Внут.	★	0190L015B	15	17.1	60	3	2
	10	Внут.	●	0190L025B	25	27.1	60	3	2
	21	Внут.	●	0190L045B	45	47.1	80	3	2
	30	Внут.	●	0190L065B	65	67.1	100	3	2
NEW	2	Внут.	●	0195L010B	10	12.0	60	3	1
1.95	5	Внут.	★	0195L015B	15	17.0	60	3	2
	10	Внут.	★	0195L025B	25	27.0	60	3	2
	20	Внут.	●	0195L045B	45	47.0	80	3	2
	30	Внут.	★	0195L065B	65	67.0	100	3	2
NEW	2	Внут.	●	0200L010B	10	11.9	60	3	1
2.00	5	Внут.	★	0200L015B	15	16.9	60	3	2
	9	Внут.	●	0200L025B	25	26.9	60	3	2
	20	Внут.	●	0200L045B	45	46.9	80	3	2
	30	Внут.	●	0200L065B	65	66.9	100	3	2
NEW	3	Внут.	●	0210L012B	12	13.7	60	3	1
2.10	7	Внут.	★	0210L020B	20	21.7	60	3	2
	11	Внут.	●	0210L030B	30	31.7	80	3	2
	23	Внут.	●	0210L055B	55	56.7	100	3	2
	30	Внут.	●	0210L075B	75	76.7	120	3	2
NEW	2	Внут.	●	0220L012B	12	13.5	60	3	1
2.20	6	Внут.	★	0220L020B	20	21.5	60	3	2
	11	Внут.	●	0220L030B	30	31.5	80	3	2
	22	Внут.	●	0220L055B	55	56.5	100	3	2
	30	Внут.	●	0220L075B	75	76.5	120	3	2
NEW	2	Внут.	●	0230L012B	12	13.3	60	3	1
2.30	6	Внут.	★	0230L020B	20	21.3	60	3	2
	10	Внут.	●	0230L030B	30	31.3	80	3	2
	21	Внут.	●	0230L055B	55	56.3	100	3	2
	30	Внут.	●	0230L075B	75	76.3	120	3	2
NEW	2	Внут.	●	0240L012B	12	13.1	60	3	1
2.40	5	Внут.	★	0240L020B	20	21.1	60	3	2
	9	Внут.	●	0240L030B	30	31.1	80	3	2
	20	Внут.	●	0240L055B	55	56.1	100	3	2
	28	Внут.	●	0240L075B	75	76.1	120	3	2
NEW	2	Внут.	★	0245L013B	13	14.0	70	4	1
2.45	5	Внут.	★	0245L020B	20	21.0	70	4	2
	11	Внут.	★	0245L035B	35	36.0	90	4	2
	24	Внут.	★	0245L065B	65	66.0	110	4	2
	30	Внут.	★	0245L090B	90	91.0	140	4	2
NEW	2	Внут.	●	0250L013B	13	15.8	70	4	1
2.50	5	Внут.	★	0250L020B	20	22.8	70	4	2
	11	Внут.	●	0250L035B	35	37.8	90	4	2
	23	Внут.	●	0250L065B	65	67.8	110	4	2
	30	Внут.	●	0250L090B	90	92.8	140	4	2

Диам. сверла D1 (мм)	Глубина сверления (l/d)	Охлаждение (Внут./Нар.)	Наличие VP15TF	Обозначение	Размеры (мм)				Тип
					L3	L2	L1	D4	
NEW	2	Внут.	●	MHS0260L013B	13	15.6	70	4	1
2.60	5	Внут.	★	0260L020B	20	22.6	70	4	2
	10	Внут.	●	0260L035B	35	37.6	90	4	2
	22	Внут.	●	0260L065B	65	67.6	110	4	2
	30	Внут.	●	0260L090B	90	92.6	140	4	2
NEW	2	Внут.	●	0270L013B	13	15.4	70	4	1
2.70	4	Внут.	★	0270L020B	20	22.4	70	4	2
	10	Внут.	●	0270L035B	35	37.4	90	4	2
	21	Внут.	●	0270L065B	65	67.4	110	4	2
	30	Внут.	●	0270L090B	90	92.4	140	4	2
NEW	2	Внут.	●	0280L014B	14	16.2	70	4	1
2.80	4	Внут.	★	0280L020B	20	22.2	70	4	2
	9	Внут.	●	0280L035B	35	37.2	90	4	2
	20	Внут.	●	0280L065B	65	67.2	110	4	2
	29	Внут.	●	0280L090B	90	92.2	140	4	2
NEW	2	Внут.	●	0290L014B	14	16.1	70	4	1
2.90	4	Внут.	★	0290L020B	20	22.1	70	4	2
	9	Внут.	●	0290L035B	35	37.1	90	4	2
	19	Внут.	●	0290L065B	65	67.1	110	4	2
	28	Внут.	●	0290L090B	90	92.1	140	4	2
NEW	2	Внут.	★	0295L014B	14	16	70	4	1
2.95	4	Внут.	★	0295L020B	20	22	70	4	2
	9	Внут.	★	0295L035B	35	37	90	4	2
	19	Внут.	●	0295L065B	65	67	110	4	2
	28	Внут.	★	0295L090B	90	92	140	4	2
3.0	4	Внут.	●	0300L020B	19	20	70	4	3
	10	Внут.	●	0300L040B	39	40	90	4	4
	17	Внут.	●	0300L060B	59	60	110	4	4
	27	Внут.	●	0300L090B	89	90	140	4	4
3.1	4	Внут.	□	0310L020B	19.5	20	70	4	3
	10	Внут.	□	0310L040B	39.5	40	90	4	4
	17	Внут.	□	0310L060B	59.5	60	110	4	4
	26	Внут.	□	0310L090B	89.5	90	140	4	4
3.2	4	Внут.	□	0320L020B	19.5	20	70	4	3
	10	Внут.	□	0320L040B	39.5	40	90	4	4
	16	Внут.	□	0320L060B	59.5	60	110	4	4
	25	Внут.	□	0320L090B	89.5	90	140	4	4
3.3	3	Внут.	□	0330L020B	19.5	20	70	4	3
	9	Внут.	□	0330L040B	39.5	40	90	4	4
	16	Внут.	□	0330L060B	59.5	60	110	4	4
	25	Внут.	□	0330L090B	89.5	90	140	4	4
3.4	3	Внут.	□	0340L020B	19.5	20	70	4	3
	9	Внут.	□	0340L040B	39.5	40	90	4	4
	15	Внут.	□	0340L060B	59.5	60	110	4	4
	24	Внут.	□	0340L090B	89.5	90	140	4	4
3.5	3	Внут.	●	0350L020B	19.5	20	70	4	3
	9	Внут.	●	0350L040B	39.5	40	90	4	4
	14	Внут.	●	0350L060B	59.5	60	110	4	4
	23	Внут.	●	0350L090B	89.5	90	140	4	4

# СВЕРЛЕНИЕ (МОНОЛИТНЫЕ ТВЕРДОСПЛАВНЫЕ СВЕРЛА)

## MHS

ТВЕРДЫЙ  
СПЛАВ

Диам. сверла D1 (мм)	Глубина сверления (l/d)	Охлаждение (Внут./Нар.)	Наличие VP15TF	Обозначение	Размеры (мм)				Тип
					L3	L2	L1	D4	
3.6	3	Внут.	□	MHS0360L020B	20	20	70	4	3
	9	Внут.	□	0360L040B	40	40	90	4	4
	14	Внут.	□	0360L060B	60	60	110	4	4
	22	Внут.	□	0360L090B	90	90	140	4	4
	30	Внут.	□	0360L120B	120	120	170	4	4
3.7	3	Внут.	□	0370L020B	20	20	70	4	3
	8	Внут.	□	0370L040B	40	40	90	4	4
	14	Внут.	□	0370L060B	60	60	110	4	4
	22	Внут.	□	0370L090B	90	90	140	4	4
3.8	3	Внут.	★	0380L020B	20	20	70	4	3
	8	Внут.	★	0380L040B	40	40	90	4	4
	13	Внут.	★	0380L060B	60	60	110	4	4
	21	Внут.	★	0380L090B	90	90	140	4	4
3.9	3	Внут.	□	0390L020B	20	20	70	4	3
	8	Внут.	□	0390L040B	40	40	90	4	4
	13	Внут.	□	0390L060B	60	60	110	4	4
	21	Внут.	□	0390L090B	90	90	140	4	4
4.0	2	Внут.	●	0400L020B	20	20	70	4	3
	7	Внут.	●	0400L040B	40	40	90	4	4
	12	Внут.	●	0400L060B	60	60	110	4	4
	20	Внут.	●	0400L090B	90	90	140	4	4
	27	Внут.	●	0400L120B	120	120	170	4	4
4.1	2	Внут.	□	0410L020B	18.5	20	70	6	3
	7	Внут.	□	0410L040B	38.5	40	90	6	4
	12	Внут.	□	0410L060B	58.5	60	110	6	4
	19	Внут.	□	0410L090B	88.5	90	140	6	4
	26	Внут.	□	0410L120B	118.5	120	170	6	4
4.2	2	Внут.	□	0420L020B	18.5	20	70	6	3
	7	Внут.	□	0420L040B	38.5	40	90	6	4
	11	Внут.	□	0420L060B	58.5	60	110	6	4
	19	Внут.	□	0420L090B	88.5	90	140	6	4
	26	Внут.	□	0420L120B	118.5	120	170	6	4
4.3	2	Внут.	□	0430L020B	18.5	20	70	6	3
	6	Внут.	□	0430L040B	38.5	40	90	6	4
	11	Внут.	□	0430L060B	58.5	60	110	6	4
	18	Внут.	□	0430L090B	88.5	90	140	6	4
	25	Внут.	□	0430L120B	118.5	120	170	6	4
4.4	2	Внут.	□	0440L020B	18.5	20	70	6	3
	6	Внут.	□	0440L040B	38.5	40	90	6	4
	11	Внут.	□	0440L060B	58.5	60	110	6	4
	18	Внут.	□	0440L090B	88.5	90	140	6	4
	24	Внут.	□	0440L120B	118.5	120	170	6	4
4.5	2	Внут.	●	0450L020B	18.5	20	70	6	3
	6	Внут.	●	0450L040B	38.5	40	90	6	4
	10	Внут.	●	0450L060B	58.5	60	110	6	4
	17	Внут.	●	0450L090B	88.5	90	140	6	4
	24	Внут.	●	0450L120B	118.5	120	170	6	4

Диам. сверла D1 (мм)	Глубина сверления (l/d)	Охлаждение (Внут./Нар.)	Наличие VP15TF	Обозначение	Размеры (мм)				Тип
					L3	L2	L1	D4	
4.6	2	Внут.	□	MHS0460L020B	19	20	70	6	3
	6	Внут.	□	0460L040B	39	40	90	6	4
	10	Внут.	□	0460L060B	59	60	110	6	4
	17	Внут.	□	0460L090B	89	90	140	6	4
	23	Внут.	□	0460L120B	119	120	170	6	4
	30	Внут.	□	0460L150B	149	150	200	6	4
4.7	2	Внут.	□	0470L020B	19	20	70	6	3
	6	Внут.	□	0470L040B	39	40	90	6	4
	10	Внут.	□	0470L060B	59	60	110	6	4
	16	Внут.	□	0470L090B	89	90	140	6	4
	23	Внут.	□	0470L120B	119	120	170	6	4
	29	Внут.	□	0470L150B	149	150	200	6	4
4.8	1	Внут.	★	0480L020B	19	20	70	6	3
	6	Внут.	★	0480L040B	39	40	90	6	4
	10	Внут.	★	0480L060B	59	60	110	6	4
	16	Внут.	★	0480L090B	89	90	140	6	4
	22	Внут.	★	0480L120B	119	120	170	6	4
4.9	1	Внут.	□	0490L020B	19	20	70	6	3
	5	Внут.	□	0490L040B	39	40	90	6	4
	10	Внут.	□	0490L060B	59	60	110	6	4
	16	Внут.	□	0490L090B	89	90	140	6	4
	22	Внут.	□	0490L120B	119	120	170	6	4
5.0	1	Внут.	●	0500L020B	19	20	70	6	3
	5	Внут.	●	0500L040B	39	40	90	6	4
	9	Внут.	●	0500L060B	59	60	110	6	4
	15	Внут.	●	0500L090B	89	90	140	6	4
	21	Внут.	●	0500L120B	119	120	170	6	4
	27	Внут.	●	0500L150B	149	150	200	6	4
5.1	3	Внут.	□	0510L030B	29.5	30	80	6	3
	9	Внут.	□	0510L060B	59.5	60	110	6	4
	15	Внут.	□	0510L090B	89.5	90	140	6	4
	21	Внут.	□	0510L120B	119.5	120	170	6	4
	27	Внут.	□	0510L150B	149.5	150	200	6	4
5.2	3	Внут.	□	0520L030B	29.5	30	80	6	3
	9	Внут.	□	0520L060B	59.5	60	110	6	4
	15	Внут.	□	0520L090B	89.5	90	140	6	4
	20	Внут.	□	0520L120B	119.5	120	170	6	4
	26	Внут.	□	0520L150B	149.5	150	200	6	4
5.3	3	Внут.	□	0530L030B	29.5	30	80	6	3
	9	Внут.	□	0530L060B	59.5	60	110	6	4
	14	Внут.	□	0530L090B	89.5	90	140	6	4
	20	Внут.	□	0530L120B	119.5	120	170	6	4
	26	Внут.	□	0530L150B	149.5	150	200	6	4
5.4	3	Внут.	□	0540L030B	29.5	30	80	6	3
	9	Внут.	□	0540L060B	59.5	60	110	6	4
	14	Внут.	□	0540L090B	89.5	90	140	6	4
	20	Внут.	□	0540L120B	119.5	120	170	6	4
	25	Внут.	□	0540L150B	149.5	150	200	6	4

(Примечание) Пожалуйста, свяжитесь с нами если Вы не нашли нужную геометрию в данном каталоге (могут быть заказаны другие диаметры и длины).

● : Есть на складе. ★ : Со склада в Японии.

□ : Нет на складе, выпускается исключительно под заказ.

Диам. сверла D1 (мм)	Глубина сверления (l/d)	Охлаждение (Внут./Нар.)	Наличие VP15TF	Обозначение	Размеры (мм)				Тип
					L3	L2	L1	D4	
5.5	3	Внут.	●	MHS0550L030B	29.5	30	80	6	3
	8	Внут.	●	0550L060B	59.5	60	110	6	4
	14	Внут.	●	0550L090B	89.5	90	140	6	4
	19	Внут.	●	0550L120B	119.5	120	170	6	4
	25	Внут.	●	0550L150B	149.5	150	200	6	4
5.6	3	Внут.	□	0560L030B	30	30	80	6	3
	8	Внут.	□	0560L060B	60	60	110	6	4
	14	Внут.	□	0560L090B	90	90	140	6	4
	19	Внут.	□	0560L120B	120	120	170	6	4
	24	Внут.	□	0560L150B	150	150	200	6	4
5.7	3	Внут.	□	0570L030B	30	30	80	6	3
	8	Внут.	□	0570L060B	60	60	110	6	4
	13	Внут.	□	0570L090B	90	90	140	6	4
	19	Внут.	□	0570L120B	120	120	170	6	4
5.8	3	Внут.	★	0580L030B	30	30	80	6	3
	8	Внут.	★	0580L060B	60	60	110	6	4
	13	Внут.	★	0580L090B	90	90	140	6	4
	18	Внут.	★	0580L120B	120	120	170	6	4
	23	Внут.	★	0580L150B	150	150	200	6	4
5.9	3	Внут.	□	0590L030B	30	30	80	6	3
	8	Внут.	□	0590L060B	60	60	110	6	4
	13	Внут.	□	0590L090B	90	90	140	6	4
	18	Внут.	□	0590L120B	120	120	170	6	4
	23	Внут.	□	0590L150B	150	150	200	6	4
6.0	2	Внут.	●	0600L030B	30	30	80	6	3
	7	Внут.	●	0600L060B	60	60	110	6	4
	12	Внут.	●	0600L090B	90	90	140	6	4
	17	Внут.	●	0600L120B	120	120	170	6	4
	22	Внут.	●	0600L150B	150	150	200	6	4
6.1	2	Внут.	□	0610L030B	28.5	30	80	8	3
	7	Внут.	□	0610L060B	58.5	60	110	8	4
	12	Внут.	□	0610L090B	88.5	90	140	8	4
	17	Внут.	□	0610L120B	118.5	120	170	8	4
	22	Внут.	□	0610L150B	148.5	150	200	8	4
6.2	2	Внут.	□	0620L030B	28.5	30	80	8	3
	7	Внут.	□	0620L060B	58.5	60	110	8	4
	12	Внут.	□	0620L090B	88.5	90	140	8	4
	17	Внут.	□	0620L120B	118.5	120	170	8	4
	21	Внут.	□	0620L150B	148.5	150	200	8	4
6.3	2	Внут.	□	0630L030B	28.5	30	80	8	3
	7	Внут.	□	0630L060B	58.5	60	110	8	4
	12	Внут.	□	0630L090B	88.5	90	140	8	4
	16	Внут.	□	0630L120B	118.5	120	170	8	4
	21	Внут.	□	0630L150B	148.5	150	200	8	4
6.4	2	Внут.	□	0640L030B	28.5	30	80	8	3
	7	Внут.	□	0640L060B	58.5	60	110	8	4
	11	Внут.	□	0640L090B	88.5	90	140	8	4
	16	Внут.	□	0640L120B	118.5	120	170	8	4
	21	Внут.	□	0640L150B	148.5	150	200	8	4

Диам. сверла D1 (мм)	Глубина сверления (l/d)	Охлаждение (Внут./Нар.)	Наличие VP15TF	Обозначение	Размеры (мм)				Тип
					L3	L2	L1	D4	
6.5	2	Внут.	●	MHS0650L030B	28.5	30	80	8	3
	6	Внут.	●	0650L060B	58.5	60	110	8	4
	11	Внут.	●	0650L090B	88.5	90	140	8	4
	16	Внут.	●	0650L120B	118.5	120	170	8	4
	20	Внут.	●	0650L150B	148.5	150	200	8	4
6.6	2	Внут.	□	0660L030B	29	30	80	8	3
	6	Внут.	□	0660L060B	59	60	110	8	4
	11	Внут.	□	0660L090B	89	90	140	8	4
	16	Внут.	□	0660L120B	119	120	170	8	4
	20	Внут.	□	0660L150B	149	150	200	8	4
6.7	2	Внут.	□	0670L030B	29	30	80	8	3
	6	Внут.	□	0670L060B	59	60	110	8	4
	11	Внут.	□	0670L090B	89	90	140	8	4
	15	Внут.	□	0670L120B	119	120	170	8	4
	20	Внут.	□	0670L150B	149	150	200	8	4
6.8	2	Внут.	★	0680L030B	29	30	80	8	3
	6	Внут.	★	0680L060B	59	60	110	8	4
	11	Внут.	★	0680L090B	89	90	140	8	4
	15	Внут.	★	0680L120B	119	120	170	8	4
	19	Внут.	★	0680L150B	149	150	200	8	4
6.9	2	Внут.	□	0690L030B	29	30	80	8	3
	6	Внут.	□	0690L060B	59	60	110	8	4
	10	Внут.	□	0690L090B	89	90	140	8	4
	15	Внут.	□	0690L120B	119	120	170	8	4
	19	Внут.	□	0690L150B	149	150	200	8	4
7.0	2	Внут.	●	0700L030B	29	30	80	8	3
	6	Внут.	●	0700L060B	59	60	110	8	4
	10	Внут.	●	0700L090B	89	90	140	8	4
	14	Внут.	●	0700L120B	119	120	170	8	4
	19	Внут.	●	0700L150B	149	150	200	8	4
7.1	2	Внут.	□	0710L030B	29.5	30	80	8	3
	6	Внут.	□	0710L060B	59.5	60	110	8	4
	10	Внут.	□	0710L090B	89.5	90	140	8	4
	14	Внут.	□	0710L120B	119.5	120	170	8	4
	19	Внут.	□	0710L150B	149.5	150	200	8	4
7.2	2	Внут.	□	0720L030B	29.5	30	80	8	3
	6	Внут.	□	0720L060B	59.5	60	110	8	4
	10	Внут.	□	0720L090B	89.5	90	140	8	4
	14	Внут.	□	0720L120B	119.5	120	170	8	4
	18	Внут.	□	0720L150B	149.5	150	200	8	4
25	Внут.	□	0720L200B	199.5	200	250	8	4	

# СВЕРЛЕНИЕ (МОНОЛИТНЫЕ ТВЕРДОСПЛАВНЫЕ СВЕРЛА)

# MHS

ТВЕРДЫЙ  
СПЛАВ

СВЕРЛЕНИЕ

Диам. сверла D1 (мм)	Глубина сверления (l/d)	Охлаждение (Внут./Нар.)	Наличие VP15TF	Обозначение	Размеры (мм)				Тип
					L3	L2	L1	D4	
7.3	2	Внут.	□	MHS0730L030B	29.5	30	80	8	3
	6	Внут.	□	0730L060B	59.5	60	110	8	4
	10	Внут.	□	0730L090B	89.5	90	140	8	4
	14	Внут.	□	0730L120B	119.5	120	170	8	4
	18	Внут.	□	0730L150B	149.5	150	200	8	4
	25	Внут.	□	0730L200B	199.5	200	250	8	4
7.4	1	Внут.	□	0740L030B	29.5	30	80	8	3
	6	Внут.	□	0740L060B	59.5	60	110	8	4
	10	Внут.	□	0740L090B	89.5	90	140	8	4
	14	Внут.	□	0740L120B	119.5	120	170	8	4
	18	Внут.	□	0740L150B	149.5	150	200	8	4
	24	Внут.	□	0740L200B	199.5	200	250	8	4
7.5	1	Внут.	●	0750L030B	29.5	30	80	8	3
	5	Внут.	●	0750L060B	59.5	60	110	8	4
	9	Внут.	●	0750L090B	89.5	90	140	8	4
	13	Внут.	●	0750L120B	119.5	120	170	8	4
	17	Внут.	●	0750L150B	149.5	150	200	8	4
	24	Внут.	●	0750L200B	199.5	200	250	8	4
7.6	1	Внут.	□	0760L030B	30	30	80	8	3
	5	Внут.	□	0760L060B	60	60	110	8	4
	9	Внут.	□	0760L090B	90	90	140	8	4
	13	Внут.	□	0760L120B	120	120	170	8	4
	17	Внут.	□	0760L150B	150	150	200	8	4
	24	Внут.	□	0760L200B	200	200	250	8	4
7.7	1	Внут.	□	0770L030B	30	30	80	8	3
	5	Внут.	□	0770L060B	60	60	110	8	4
	9	Внут.	□	0770L090B	90	90	140	8	4
	13	Внут.	□	0770L120B	120	120	170	8	4
	17	Внут.	□	0770L150B	150	150	200	8	4
	23	Внут.	□	0770L200B	200	200	250	8	4
7.8	1	Внут.	★	0780L030B	30	30	80	8	3
	5	Внут.	★	0780L060B	60	60	110	8	4
	9	Внут.	★	0780L090B	90	90	140	8	4
	13	Внут.	★	0780L120B	120	120	170	8	4
	17	Внут.	★	0780L150B	150	150	200	8	4
	23	Внут.	★	0780L200B	200	200	250	8	4
7.9	1	Внут.	□	0790L030B	30	30	80	8	3
	5	Внут.	□	0790L060B	60	60	110	8	4
	9	Внут.	□	0790L090B	90	90	140	8	4
	13	Внут.	□	0790L120B	120	120	170	8	4
	16	Внут.	□	0790L150B	150	150	200	8	4
	29	Внут.	□	0790L250B	250	250	300	8	4

Диам. сверла D1 (мм)	Глубина сверления (l/d)	Охлаждение (Внут./Нар.)	Наличие VP15TF	Обозначение	Размеры (мм)				Тип
					L3	L2	L1	D4	
8.0	1	Внут.	●	MHS0800L030B	30	30	80	8	3
	5	Внут.	●	0800L060B	60	60	110	8	4
	9	Внут.	●	0800L090B	90	90	140	8	4
	12	Внут.	●	0800L120B	120	120	170	8	4
	16	Внут.	●	0800L150B	150	150	200	8	4
	22	Внут.	●	0800L200B	200	200	250	8	4
	29	Внут.	●	0800L250B	250	250	300	8	4
	8.1	2	Внут.	□	0810L040B	38.5	40	100	10
8		Внут.	□	0810L090B	88.5	90	150	10	4
12		Внут.	□	0810L120B	118.5	120	180	10	4
16		Внут.	□	0810L150B	148.5	150	210	10	4
22		Внут.	□	0810L200B	198.5	200	260	10	4
28		Внут.	□	0810L250B	248.5	250	310	10	4
8.2	2	Внут.	□	0820L040B	38.5	40	100	10	3
	8	Внут.	□	0820L090B	88.5	90	150	10	4
	12	Внут.	□	0820L120B	118.5	120	180	10	4
	16	Внут.	□	0820L150B	148.5	150	210	10	4
	22	Внут.	□	0820L200B	198.5	200	260	10	4
	28	Внут.	□	0820L250B	248.5	250	310	10	4
8.3	2	Внут.	□	0830L040B	38.5	40	100	10	3
	8	Внут.	□	0830L090B	88.5	90	150	10	4
	12	Внут.	□	0830L120B	118.5	120	180	10	4
	15	Внут.	□	0830L150B	148.5	150	210	10	4
	21	Внут.	□	0830L200B	198.5	200	260	10	4
	27	Внут.	□	0830L250B	248.5	250	310	10	4
8.4	2	Внут.	□	0840L040B	38.5	40	100	10	3
	8	Внут.	□	0840L090B	88.5	90	150	10	4
	12	Внут.	□	0840L120B	118.5	120	180	10	4
	15	Внут.	□	0840L150B	148.5	150	210	10	4
	21	Внут.	□	0840L200B	198.5	200	260	10	4
	27	Внут.	□	0840L250B	248.5	250	310	10	4
8.5	2	Внут.	●	0850L040B	38.5	40	100	10	3
	8	Внут.	●	0850L090B	88.5	90	150	10	4
	11	Внут.	●	0850L120B	118.5	120	180	10	4
	15	Внут.	●	0850L150B	148.5	150	210	10	4
	21	Внут.	●	0850L200B	198.5	200	260	10	4
	27	Внут.	●	0850L250B	248.5	250	310	10	4
8.6	2	Внут.	□	0860L040B	39	40	100	10	3
	8	Внут.	□	0860L090B	89	90	150	10	4
	11	Внут.	□	0860L120B	119	120	180	10	4
	15	Внут.	□	0860L150B	149	150	210	10	4
	21	Внут.	□	0860L200B	199	200	260	10	4
	26	Внут.	□	0860L250B	249	250	310	10	4
8.7	2	Внут.	□	0870L040B	39	40	100	10	3
	8	Внут.	□	0870L090B	89	90	150	10	4
	11	Внут.	□	0870L120B	119	120	180	10	4
	15	Внут.	□	0870L150B	149	150	210	10	4
	20	Внут.	□	0870L200B	199	200	260	10	4
	26	Внут.	□	0870L250B	249	250	310	10	4

(Примечание) Пожалуйста, свяжитесь с нами если Вы не нашли нужную геометрию в данном каталоге (могут быть заказаны другие диаметры и длины).

● : Есть на складе. ★ : Со склада в Японии.

□ : Нет на складе, выпускается исключительно под заказ.

L106

Заказ инструмента: <http://steelcam.org> | 8 (343) 382-52-03 | [sales@sverla-ekb.ru](mailto:sales@sverla-ekb.ru)

Диам. сверла D1 (мм)	Глубина сверления (l/d)	Охлаждение (Внут./Нар.)	Наличие VP15TF	Обозначение	Размеры (мм)				Тип
					L3	L2	L1	D4	
8.8	2	Внут.	★	MHS0880L040B	39	40	100	10	3
	8	Внут.	★	0880L090B	89	90	150	10	4
	11	Внут.	★	0880L120B	119	120	180	10	4
	14	Внут.	★	0880L150B	149	150	210	10	4
	20	Внут.	★	0880L200B	199	200	260	10	4
	26	Внут.	★	0880L250B	249	250	310	10	4
8.9	2	Внут.	□	0890L040B	39	40	100	10	3
	7	Внут.	□	0890L090B	89	90	150	10	4
	11	Внут.	□	0890L120B	119	120	180	10	4
	14	Внут.	□	0890L150B	149	150	210	10	4
	20	Внут.	□	0890L200B	199	200	260	10	4
9.0	2	Внут.	●	0900L040B	39	40	100	10	3
	7	Внут.	●	0900L090B	89	90	150	10	4
	11	Внут.	●	0900L120B	119	120	180	10	4
	14	Внут.	●	0900L150B	149	150	210	10	4
	20	Внут.	●	0900L200B	199	200	260	10	4
9.1	2	Внут.	□	0910L040B	39.5	40	100	10	3
	7	Внут.	□	0910L090B	89.5	90	150	10	4
	11	Внут.	□	0910L120B	119.5	120	180	10	4
	14	Внут.	□	0910L150B	149.5	150	210	10	4
	19	Внут.	□	0910L200B	199.5	200	260	10	4
	25	Внут.	□	0910L250B	249.5	250	310	10	4
9.2	2	Внут.	□	0920L040B	39.5	40	100	10	3
	7	Внут.	□	0920L090B	89.5	90	150	10	4
	10	Внут.	□	0920L120B	119.5	120	180	10	4
	14	Внут.	□	0920L150B	149.5	150	210	10	4
	19	Внут.	□	0920L200B	199.5	200	260	10	4
	25	Внут.	□	0920L250B	249.5	250	310	10	4
9.3	2	Внут.	□	0930L040B	39.5	40	100	10	3
	7	Внут.	□	0930L090B	89.5	90	150	10	4
	10	Внут.	□	0930L120B	119.5	120	180	10	4
	14	Внут.	□	0930L150B	149.5	150	210	10	4
	19	Внут.	□	0930L200B	199.5	200	260	10	4
	24	Внут.	□	0930L250B	249.5	250	310	10	4
9.4	2	Внут.	□	0940L040B	39.5	40	100	10	3
	7	Внут.	□	0940L090B	89.5	90	150	10	4
	10	Внут.	□	0940L120B	119.5	120	180	10	4
	13	Внут.	□	0940L150B	149.5	150	210	10	4
	19	Внут.	□	0940L200B	199.5	200	260	10	4
	24	Внут.	□	0940L250B	249.5	250	310	10	4

Диам. сверла D1 (мм)	Глубина сверления (l/d)	Охлаждение (Внут./Нар.)	Наличие VP15TF	Обозначение	Размеры (мм)				Тип
					L3	L2	L1	D4	
9.5	2	Внут.	●	MHS0950L040B	39.5	40	100	10	3
	7	Внут.	●	0950L090B	89.5	90	150	10	4
	10	Внут.	●	0950L120B	119.5	120	180	10	4
	13	Внут.	●	0950L150B	149.5	150	210	10	4
	18	Внут.	●	0950L200B	199.5	200	260	10	4
	24	Внут.	●	0950L250B	249.5	250	310	10	4
	29	Внут.	●	0950L300B	299.5	300	360	10	4
9.6	2	Внут.	□	0960L040B	40	40	100	10	3
	7	Внут.	□	0960L090B	90	90	150	10	4
	10	Внут.	□	0960L120B	120	120	180	10	4
	13	Внут.	□	0960L150B	150	150	210	10	4
	18	Внут.	□	0960L200B	200	200	260	10	4
	24	Внут.	□	0960L250B	250	250	310	10	4
9.7	2	Внут.	□	0970L040B	40	40	100	10	3
	7	Внут.	□	0970L090B	90	90	150	10	4
	10	Внут.	□	0970L120B	120	120	180	10	4
	13	Внут.	□	0970L150B	150	150	210	10	4
	18	Внут.	□	0970L200B	200	200	260	10	4
	23	Внут.	□	0970L250B	250	250	310	10	4
9.8	2	Внут.	★	0980L040B	40	40	100	10	3
	7	Внут.	★	0980L090B	90	90	150	10	4
	10	Внут.	★	0980L120B	120	120	180	10	4
	13	Внут.	★	0980L150B	150	150	210	10	4
	18	Внут.	★	0980L200B	200	200	260	10	4
	23	Внут.	★	0980L250B	250	250	310	10	4
9.9	2	Внут.	□	0990L040B	40	40	100	10	3
	7	Внут.	□	0990L090B	90	90	150	10	4
	10	Внут.	□	0990L120B	120	120	180	10	4
	13	Внут.	□	0990L150B	150	150	210	10	4
	18	Внут.	□	0990L200B	200	200	260	10	4
	23	Внут.	□	0990L250B	250	250	310	10	4
10.0	1	Внут.	●	1000L040B	40	40	100	10	3
	6	Внут.	●	1000L090B	90	90	150	10	4
	9	Внут.	●	1000L120B	120	120	180	10	4
	12	Внут.	●	1000L150B	150	150	210	10	4
	17	Внут.	●	1000L200B	200	200	260	10	4
	22	Внут.	●	1000L250B	250	250	310	10	4
10.1	1	Внут.	□	1010L040B	38.5	40	100	12	3
	6	Внут.	□	1010L090B	88.5	90	150	12	4
	9	Внут.	□	1010L120B	118.5	120	180	12	4
	12	Внут.	□	1010L150B	148.5	150	210	12	4
	17	Внут.	□	1010L200B	198.5	200	260	12	4
	22	Внут.	□	1010L250B	248.5	250	310	12	4

# СВЕРЛЕНИЕ (МОНОЛИТНЫЕ ТВЕРДОСПЛАВНЫЕ СВЕРЛА)

## MHS

ТВЕРДЫЙ  
СПЛАВ

Диам. сверла D1 (мм)	Глубина сверления (l/d)	Охлаждение (Внут./Нар.)	Наличие VP15TF	Обозначение	Размеры (мм)				Тип
					L3	L2	L1	D4	
10.2	1	Внут.	□	MHS1020L040B	38.5	40	100	12	3
	6	Внут.	□	1020L090B	88.5	90	150	12	4
	9	Внут.	□	1020L120B	118.5	120	180	12	4
	12	Внут.	□	1020L150B	148.5	150	210	12	4
	17	Внут.	□	1020L200B	198.5	200	260	12	4
	22	Внут.	□	1020L250B	248.5	250	310	12	4
	27	Внут.	□	1020L300B	298.5	300	360	12	4
10.3	1	Внут.	□	1030L040B	38.5	40	100	12	3
	6	Внут.	□	1030L090B	88.5	90	150	12	4
	9	Внут.	□	1030L120B	118.5	120	180	12	4
	12	Внут.	□	1030L150B	148.5	150	210	12	4
	17	Внут.	□	1030L200B	198.5	200	260	12	4
	22	Внут.	□	1030L250B	248.5	250	310	12	4
	26	Внут.	□	1030L300B	298.5	300	360	12	4
10.4	1	Внут.	□	1040L040B	38.5	40	100	12	3
	6	Внут.	□	1040L090B	88.5	90	150	12	4
	9	Внут.	□	1040L120B	118.5	120	180	12	4
	12	Внут.	□	1040L150B	148.5	150	210	12	4
	17	Внут.	□	1040L200B	198.5	200	260	12	4
	21	Внут.	□	1040L250B	248.5	250	310	12	4
	26	Внут.	□	1040L300B	298.5	300	360	12	4
10.5	1	Внут.	●	1050L040B	38.5	40	100	12	3
	6	Внут.	●	1050L090B	88.5	90	150	12	4
	9	Внут.	●	1050L120B	118.5	120	180	12	4
	12	Внут.	●	1050L150B	148.5	150	210	12	4
	16	Внут.	●	1050L200B	198.5	200	260	12	4
	21	Внут.	●	1050L250B	248.5	250	310	12	4
	26	Внут.	●	1050L300B	298.5	300	360	12	4
10.6	1	Внут.	□	1060L040B	39	40	100	12	3
	6	Внут.	□	1060L090B	89	90	150	12	4
	9	Внут.	□	1060L120B	119	120	180	12	4
	12	Внут.	□	1060L150B	149	150	210	12	4
	16	Внут.	□	1060L200B	199	200	260	12	4
	21	Внут.	□	1060L250B	249	250	310	12	4
	26	Внут.	□	1060L300B	299	300	360	12	4
10.7	1	Внут.	□	1070L040B	39	40	100	12	3
	6	Внут.	□	1070L090B	89	90	150	12	4
	9	Внут.	□	1070L120B	119	120	180	12	4
	11	Внут.	□	1070L150B	149	150	210	12	4
	16	Внут.	□	1070L200B	199	200	260	12	4
	21	Внут.	□	1070L250B	249	250	310	12	4
	25	Внут.	□	1070L300B	299	300	360	12	4
10.8	1	Внут.	★	1080L040B	39	40	100	12	3
	6	Внут.	★	1080L090B	89	90	150	12	4
	9	Внут.	★	1080L120B	119	120	180	12	4
	11	Внут.	★	1080L150B	149	150	210	12	4
	16	Внут.	★	1080L200B	199	200	260	12	4
	21	Внут.	★	1080L250B	249	250	310	12	4
	25	Внут.	★	1080L300B	299	300	360	12	4

Диам. сверла D1 (мм)	Глубина сверления (l/d)	Охлаждение (Внут./Нар.)	Наличие VP15TF	Обозначение	Размеры (мм)				Тип
					L3	L2	L1	D4	
10.9	1	Внут.	□	MHS1090L040B	39	40	100	12	3
	6	Внут.	□	1090L090B	89	90	150	12	4
	8	Внут.	□	1090L120B	119	120	180	12	4
	11	Внут.	□	1090L150B	149	150	210	12	4
	16	Внут.	□	1090L200B	199	200	260	12	4
	20	Внут.	□	1090L250B	249	250	310	12	4
	25	Внут.	□	1090L300B	299	300	360	12	4
11.0	1	Внут.	●	1100L040B	39	40	100	12	3
	6	Внут.	●	1100L090B	89	90	150	12	4
	8	Внут.	●	1100L120B	119	120	180	12	4
	11	Внут.	●	1100L150B	149	150	210	12	4
	16	Внут.	●	1100L200B	199	200	260	12	4
	20	Внут.	●	1100L250B	249	250	310	12	4
	25	Внут.	●	1100L300B	299	300	360	12	4
11.1	1	Внут.	□	1110L040B	39.5	40	100	12	3
	6	Внут.	□	1110L090B	89.5	90	150	12	4
	8	Внут.	□	1110L120B	119.5	120	180	12	4
	11	Внут.	□	1110L150B	149.5	150	210	12	4
	15	Внут.	□	1110L200B	199.5	200	260	12	4
	20	Внут.	□	1110L250B	249.5	250	310	12	4
	24	Внут.	□	1110L300B	299.5	300	360	12	4
11.2	1	Внут.	□	1120L040B	39.5	40	100	12	3
	5	Внут.	□	1120L090B	89.5	90	150	12	4
	8	Внут.	□	1120L120B	119.5	120	180	12	4
	11	Внут.	□	1120L150B	149.5	150	210	12	4
	15	Внут.	□	1120L200B	199.5	200	260	12	4
	20	Внут.	□	1120L250B	249.5	250	310	12	4
	24	Внут.	□	1120L300B	299.5	300	360	12	4
11.3	1	Внут.	□	1130L040B	39.5	40	100	12	3
	5	Внут.	□	1130L090B	89.5	90	150	12	4
	8	Внут.	□	1130L120B	119.5	120	180	12	4
	11	Внут.	□	1130L150B	149.5	150	210	12	4
	15	Внут.	□	1130L200B	199.5	200	260	12	4
	20	Внут.	□	1130L250B	249.5	250	310	12	4
	24	Внут.	□	1130L300B	299.5	300	360	12	4
11.4	1	Внут.	□	1140L040B	39.5	40	100	12	3
	5	Внут.	□	1140L090B	89.5	90	150	12	4
	8	Внут.	□	1140L120B	119.5	120	180	12	4
	11	Внут.	□	1140L150B	149.5	150	210	12	4
	15	Внут.	□	1140L200B	199.5	200	260	12	4
	19	Внут.	□	1140L250B	249.5	250	310	12	4
	24	Внут.	□	1140L300B	299.5	300	360	12	4
11.5	1	Внут.	●	1150L040B	39.5	40	100	12	3
	5	Внут.	●	1150L090B	89.5	90	150	12	4
	8	Внут.	●	1150L120B	119.5	120	180	12	4
	10	Внут.	●	1150L150B	149.5	150	210	12	4
	15	Внут.	●	1150L200B	199.5	200	260	12	4
	19	Внут.	●	1150L250B	249.5	250	310	12	4
	24	Внут.	●	1150L300B	299.5	300	360	12	4

(Примечание) Пожалуйста, свяжитесь с нами если Вы не нашли нужную геометрию в данном каталоге (могут быть заказаны другие диаметры и длины).

● : Есть на складе. ★ : Со склада в Японии.

□ : Нет на складе, выпускается исключительно под заказ.

L108

Заказ инструмента: <http://steelcam.org> | 8 (343) 382-52-03 | [sales@sverla-ekb.ru](mailto:sales@sverla-ekb.ru)

Диам. сверла D1 (мм)	Глубина сверления (l/d)	Охлаждение (Внут./Нар.)	Наличие VP15TF	Обозначение	Размеры (мм)				Тип
					L3	L2	L1	D4	
11.6	1	Внут.	□	<b>MHS1160L040B</b>	40	40	100	12	3
	5	Внут.	□	<b>1160L090B</b>	90	90	150	12	4
	8	Внут.	□	<b>1160L120B</b>	120	120	180	12	4
	10	Внут.	□	<b>1160L150B</b>	150	150	210	12	4
	15	Внут.	□	<b>1160L200B</b>	200	200	260	12	4
	19	Внут.	□	<b>1160L250B</b>	250	250	310	12	4
	23	Внут.	□	<b>1160L300B</b>	300	300	360	12	4
11.7	1	Внут.	□	<b>1170L040B</b>	40	40	100	12	3
	5	Внут.	□	<b>1170L090B</b>	90	90	150	12	4
	8	Внут.	□	<b>1170L120B</b>	120	120	180	12	4
	10	Внут.	□	<b>1170L150B</b>	150	150	210	12	4
	15	Внут.	□	<b>1170L200B</b>	200	200	260	12	4
	19	Внут.	□	<b>1170L250B</b>	250	250	310	12	4
	23	Внут.	□	<b>1170L300B</b>	300	300	360	12	4
11.8	1	Внут.	★	<b>1180L040B</b>	40	40	100	12	3
	5	Внут.	★	<b>1180L090B</b>	90	90	150	12	4
	8	Внут.	★	<b>1180L120B</b>	120	120	180	12	4
	10	Внут.	★	<b>1180L150B</b>	150	150	210	12	4
	14	Внут.	★	<b>1180L200B</b>	200	200	260	12	4
	19	Внут.	★	<b>1180L250B</b>	250	250	310	12	4
	23	Внут.	★	<b>1180L300B</b>	300	300	360	12	4
11.9	1	Внут.	□	<b>1190L040B</b>	40	40	100	12	3
	5	Внут.	□	<b>1190L090B</b>	90	90	150	12	4
	8	Внут.	□	<b>1190L120B</b>	120	120	180	12	4
	10	Внут.	□	<b>1190L150B</b>	150	150	210	12	4
	14	Внут.	□	<b>1190L200B</b>	200	200	260	12	4
	19	Внут.	□	<b>1190L250B</b>	250	250	310	12	4
	23	Внут.	□	<b>1190L300B</b>	300	300	360	12	4
12.0	1	Внут.	●	<b>1200L040B</b>	40	40	100	12	3
	5	Внут.	●	<b>1200L090B</b>	90	90	150	12	4
	7	Внут.	●	<b>1200L120B</b>	120	120	180	12	4
	10	Внут.	●	<b>1200L150B</b>	150	150	210	12	4
	14	Внут.	●	<b>1200L200B</b>	200	200	260	12	4
	18	Внут.	●	<b>1200L250B</b>	250	250	310	12	4
	22	Внут.	●	<b>1200L300B</b>	300	300	360	12	4

### РЕКОМЕНДУЕМЫЕ РЕЖИМЫ РЕЗАНИЯ

Диам. сверла (мм)	Скорость резания (м/мин)	Частота вращения (мин <sup>-1</sup> )	Малоуглеродистая сталь (≤180НВ), Углеродистая сталь Легированная сталь (180—280НВ)		Ферритная и мартенситная нержавеющая сталь (>200НВ)			
			Подача (мин.—макс.) (мм/об)	Подача (мм/мин)	Скорость резания (м/мин)	Частота вращения (мин <sup>-1</sup> )	Подача (мин.—макс.) (мм/об)	Подача (мм/мин)
1.0	40	12700	0.030 (0.020—0.040)	380	20	6400	0.030 (0.020—0.040)	190
1.2	50	13300	0.035 (0.025—0.050)	465	30	8000	0.035 (0.025—0.050)	280
1.6	60	11900	0.050 (0.030—0.065)	595	40	8000	0.050 (0.030—0.065)	400
2.0	70	11100	0.060 (0.040—0.080)	665	50	8000	0.060 (0.040—0.080)	480
2.5	80	10200	0.075 (0.050—0.100)	765	60	7600	0.075 (0.050—0.100)	570
3.2	80	8000	0.100 (0.070—0.130)	800	60	6000	0.100 (0.070—0.130)	600
4.0	80	6400	0.100 (0.090—0.110)	640	60	4800	0.090 (0.080—0.090)	430
5.0	80	5100	0.130 (0.110—0.140)	665	60	3800	0.110 (0.100—0.120)	420
6.3	80	4000	0.160 (0.140—0.180)	640	60	3000	0.140 (0.130—0.150)	420
8.0	80	3200	0.200 (0.180—0.230)	640	60	2400	0.170 (0.160—0.190)	410
10.0	80	2600	0.250 (0.220—0.280)	650	60	1900	0.220 (0.200—0.230)	420
12.0	80	2100	0.300 (0.270—0.340)	630	60	1600	0.260 (0.240—0.280)	415

Диам. сверла (мм)	Скорость резания (м/мин)	Частота вращения (мин <sup>-1</sup> )	Предварительно закалённая сталь (35—45HRC), Легированная инструментальная сталь (≤350НВ)		Закалённая Сталь (40—55HRC), Нержавеющая сталь PH (<450НВ)			
			Подача (мин.—макс.) (мм/об)	Подача (мм/мин)	Скорость резания (м/мин)	Частота вращения (мин <sup>-1</sup> )	Подача (мин.—макс.) (мм/об)	Подача (мм/мин)
1.0	20	6400	0.025 (0.020—0.030)	160	40	12700	0.020 (0.015—0.025)	255
1.2	30	8000	0.030 (0.020—0.035)	240	40	10600	0.025 (0.020—0.030)	265
1.6	40	8000	0.040 (0.030—0.045)	320	50	10000	0.035 (0.025—0.040)	350
2.0	50	8000	0.045 (0.035—0.060)	360	50	8000	0.040 (0.030—0.050)	320
2.5	60	7600	0.060 (0.045—0.075)	455	60	7600	0.050 (0.040—0.065)	380
3.2	60	6000	0.080 (0.060—0.090)	480	60	6000	0.060 (0.050—0.080)	360
4.0	60	4800	0.080 (0.070—0.100)	385	60	4800	0.080 (0.060—0.100)	385
5.0	60	3800	0.110 (0.090—0.130)	420	60	3800	0.100 (0.080—0.130)	380
6.3	60	3000	0.130 (0.110—0.160)	390	60	3000	0.110 (0.090—0.130)	330
8.0	60	2400	0.170 (0.140—0.200)	410	60	2400	0.140 (0.120—0.160)	335
10.0	60	1900	0.210 (0.170—0.250)	400	60	1900	0.170 (0.140—0.200)	325
12.0	60	1600	0.250 (0.210—0.300)	400	60	1600	0.210 (0.170—0.240)	335

Диам. сверла (мм)	Скорость резания (м/мин)	Частота вращения (мин <sup>-1</sup> )	Закалённая Сталь (40—55HRC), Жаропрочные сплавы	
			Подача (мин.—макс.) (мм/об)	Подача (мм/мин)
1.0	10	3200	0.015 (0.015—0.020)	50
1.2	10	2700	0.020 (0.015—0.025)	55
1.6	10	2000	0.025 (0.020—0.030)	50
2.0	20	3200	0.035 (0.025—0.040)	110
2.5	20	2600	0.040 (0.030—0.050)	105
3.2	20	2000	0.050 (0.040—0.070)	100
4.0	30	2400	0.070 (0.050—0.080)	170
5.0	30	1900	0.080 (0.060—0.100)	150
6.3	30	1500	0.090 (0.080—0.110)	135
8.0	40	1600	0.120 (0.100—0.130)	190
10.0	40	1300	0.150 (0.130—0.170)	195
12.0	40	1100	0.180 (0.150—0.200)	200

(Примечание 1) При сверлении отверстий с глубиной сверления свыше l/d=10 рекомендуется сначала просверлить направляющее отверстие. (В противном случае возможна поломка сверла.)

(Примечание 2) Используйте самое короткое сверло такого же диаметра для сверления направляющего отверстия.

## ИНСТРУКЦИЯ ПО ЭКСПЛУАТАЦИИ

### Крепление сверла

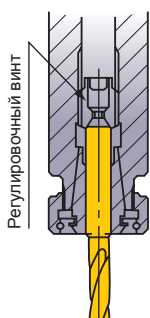

Цанговый патрон с упорным подшипником надежно держит сверло.

### Длина сверла

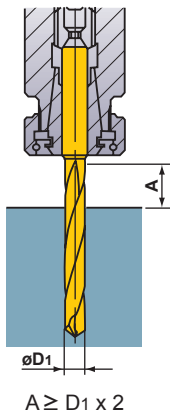

$$A \geq D_1 \times 2$$

### Установка сверла

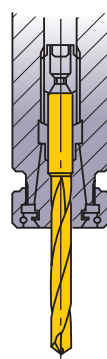

Не прижимать по режущей кромке.

### Тип охлаждения через сквозные отверстия

Тип охлаждения через шпindel

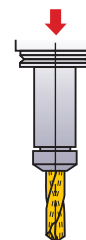

Тип охлаждения на вращающийся шпindel станка

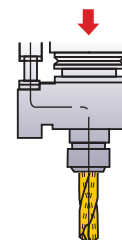

Давление охлаждающей среды должно составлять ок. 1.5–7МПа  
Рекомендованная Давление СОЖ:  $\geq 3\text{Мра}$

### Установка сверла

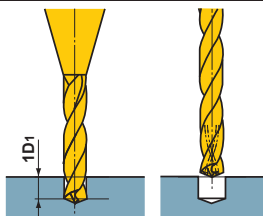

- 1) Выполните направляющее отверстие приблиз.  $1D_1$  ( $D_1$ : диаметр сверла) при помощи MHS со сверлами, имеющими минимальную длину режущей кромки.
- 2) Используйте направляющее отверстие и выполняйте обработку сверлом с каналом для подвода СОЖ. В зависимости от применения выполняйте сверление с периодическим выводом сверла.

### Рекомендации по использованию СОЖ

- 1) Рекомендуется регулярно проводить замену СОЖ во избежании забивания каналов в сверле.
- 2) Для предотвращения забивания мелкой стружкой отверстий сверла используйте фильтр, как профилактическую меру. Для сверл малого диаметра рекомендуется применять фильтр с более мелкими отверстиями.

### Тонкая заготовка

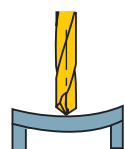

Если наблюдается отгиб.

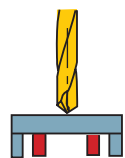

Необходима опора для заготовки.

### Прерывистое резание

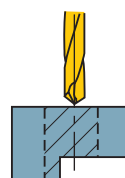

Один процесс

- ① Уменьшить подачу при сверлении разомкнутой детали (при прерывистом сверлении).

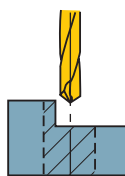

Требуется предварительная обработка.

- ① До сверления предварительно подрезать торец концевой фрезой.

### Ступенчатые отверстия.

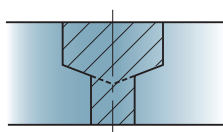

- ① Разделите операцию на два перехода.
  - ② Сначала просверлите отверстие большего диаметра.
- \* Инструменты для снятия фаски и цекования могут быть изготовлены по заказу.

### Образование заусенцев и выкрашивание заготовки.

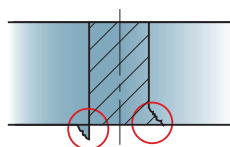

- ① На выходе сверла из отверстия снизьте подачу.
- ② Измените угол при вершине.

### РУКОВОДСТВО ПО ИСПОЛЬЗОВАНИЮ MHS (L/D ≥ 10)

## СВЕРЛЕНИЕ НА ПЛОСКИХ ПОВЕРХНОСТЯХ ● Сделать глухое отверстие

### 1. Выполнить направляющее отверстие

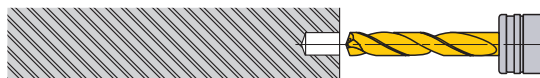

- ① Используйте сверло с большим двойным углом в плане, чем у сверла длинного исполнения. Используйте сверло с минимальной длиной режущей кромки.
- ② Для обеспечения высокой точности отверстия, точно выполняйте направляющее отверстие.
- ③ Глубина сверления: около 1D или глубже. (Выберите глубину направляющего отверстия, соответствующую длине сверхдлинного сверла.)

### 2. Предварительная обработка при помощи длинного сверла.

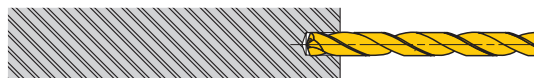

- ① Вводите сверло в направляющее отверстие при низких оборотах (вращение 1000 мин<sup>-1</sup>, скорость подачи 0,2—0,3 мм/об).
- ② Остановить сверло для глубоких отверстий 0,5—1 мм до достижения дна направляющего отверстия.

### 3. Сверление глубокого отверстия

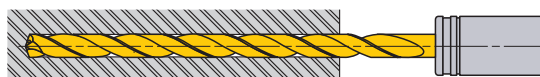

- ① Увеличьте частоту вращения и подачу за цикл и просверлите до желаемой глубины.

### 4. Отвод сверла из отверстия



- ① После окончания сверления снизьте обороты, не доходя приблизительно 0,5—1 мм до конца отверстия (частота вращения около 1000 мин<sup>-1</sup>).
- ② Выньте сверло примерно до глубины направляющего отверстия (Vf=3000мм/мин.)
- ③ Выведите сверло из направляющего отверстия с уменьшенной частотой вращения (n=300, Vf=3000мм/мин)

## СВЕРЛЕНИЕ НА НАКЛОННЫХ ПОВЕРХНОСТЯХ ● Отверстия на изогнутых заготовках

### 1. Плоское фрезерование



- ① Отфрезеруйте плоскую поверхность на заготовке фрезой, такого же диаметра, что и диаметр желаемого отверстия.

### 2. Выполнить направляющее отверстие



- ① Используйте сверло с большим двойным углом в плане, чем у сверла длинного исполнения. Используйте сверло с минимальной длиной режущей кромки.
- ② Для обеспечения высокой точности отверстия, точно выполняйте направляющее отверстие.
- ③ Глубина сверления: около 1D или глубже. (Выберите глубину направляющего отверстия, соответствующую длине сверхдлинного сверла.)

### 3. Предварительная обработка при помощи длинного сверла.



- ① Вводите сверло в направляющее отверстие на низких оборотах (частота вращения 1000 мин<sup>-1</sup>, скорость подачи 0,2—0,3 мм/об).
- ② Остановить длинное сверло за 0,5—1 мм до достижения дна направляющего отверстия.

### 4. Сверление глубокого отверстия



- ① Увеличьте частоту вращения и подачу за цикл и просверлите до желаемой глубины.

### 5. Проходные отверстия

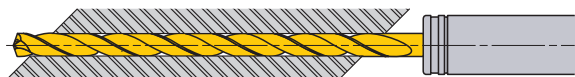

- ① При выходе из заготовки режущая кромка сверла может обломиться.
- ② При выводе сверла в отверстие снизьте скорость подачи.

### 6. Отвод сверла из отверстия

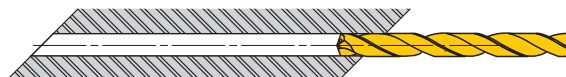

- ① Обработайте отверстие со скоростью резания 20—30м/мин и подачей 0,2—0,3мм/об.
- ② Поднимите сверло из направляющего отверстия до глубины начальной точки с подачей 3000мм/мин.

Углеродистая сталь Легированная сталь	Закалённая сталь	Нержавеющая сталь	Чугун	Лёгкий сплав	Жаропрочные сплавы
	◎				○

	D1 ≤ 3	3 < D1 ≤ 6	6 < D1 ≤ 10	10 < D1 ≤ 16
	<sup>0</sup> <sub>-0.014</sub>	<sup>0</sup> <sub>-0.018</sub>	<sup>0</sup> <sub>-0.022</sub>	<sup>0</sup> <sub>-0.027</sub>
	<sup>0</sup> <sub>-0.009</sub>	<sup>0</sup> <sub>-0.012</sub>	<sup>0</sup> <sub>-0.015</sub>	<sup>0</sup> <sub>-0.018</sub>

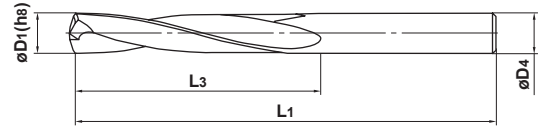

● Специальная геометрия для сверления материалов с высокой твердостью (60 HRC).

Диам. сверла D1 (мм)	Глубина сверления (l/d)	Охлаждение (Внут./Нар.)	Наличие VP15TF	Обозначение	Размеры (мм)		
					L3	L1	D4
2.5	3	Нар.	★	VCHSMD0250	20	55	2.5
2.6	3	Нар.	★	D0260	20	55	2.6
2.7	3	Нар.	★	D0270	20	55	2.7
2.8	3	Нар.	★	D0280	21	60	2.8
2.9	3	Нар.	★	D0290	21	60	2.9
3.0	3	Нар.	★	D0300	21	60	3
3.1	3	Нар.	★	D0310	24	60	3.1
3.2	3	Нар.	★	D0320	24	60	3.2
3.3	3	Нар.	★	D0330	24	60	3.3
3.4	3	Нар.	★	D0340	24	60	3.4
3.5	3	Нар.	★	D0350	24	60	3.5
3.6	3	Нар.	★	D0360	27	60	3.6
3.7	3	Нар.	★	D0370	27	60	3.7
3.8	3	Нар.	★	D0380	27	60	3.8
3.9	3	Нар.	★	D0390	27	60	3.9
4.0	3	Нар.	★	D0400	27	60	4
4.1	3	Нар.	★	D0410	29	63	4.1
4.2	3	Нар.	★	D0420	29	63	4.2
4.3	3	Нар.	★	D0430	29	63	4.3
4.4	3	Нар.	★	D0440	29	63	4.4
4.5	3	Нар.	★	D0450	29	63	4.5
4.6	3	Нар.	★	D0460	32	68	4.6
4.7	3	Нар.	★	D0470	32	68	4.7
4.8	3	Нар.	★	D0480	32	68	4.8
4.9	3	Нар.	★	D0490	32	68	4.9
5.0	3	Нар.	★	D0500	32	68	5
5.1	3	Нар.	★	D0510	34	72	5.1
5.2	3	Нар.	★	D0520	34	72	5.2
5.3	3	Нар.	★	D0530	34	72	5.3
5.4	3	Нар.	★	D0540	34	72	5.4

Диам. сверла D1 (мм)	Глубина сверления (l/d)	Охлаждение (Внут./Нар.)	Наличие VP15TF	Обозначение	Размеры (мм)		
					L3	L1	D4
5.5	3	Нар.	★	VCHSMD0550	34	72	5.5
5.6	3	Нар.	★	D0560	36	74	5.6
5.7	3	Нар.	★	D0570	36	74	5.7
5.8	3	Нар.	★	D0580	36	74	5.8
5.9	3	Нар.	★	D0590	36	74	5.9
6.0	3	Нар.	★	D0600	41	81	6
6.5	3	Нар.	★	D0650	41	81	6.5
6.9	3	Нар.	★	D0690	43	83	6.9
7.0	3	Нар.	★	D0700	43	83	7
7.5	3	Нар.	★	D0750	45	87	7.5
8.0	3	Нар.	★	D0800	48	90	8
8.5	3	Нар.	★	D0850	53	96	8.5
8.6	3	Нар.	★	D0860	55	98	8.6
9.0	3	Нар.	★	D0900	55	98	9
9.5	3	Нар.	★	D0950	58	102	9.5
10.0	3	Нар.	★	D1000	60	105	10
10.4	3	Нар.	★	D1040	66	112	10.4
10.5	3	Нар.	★	D1050	66	112	10.5
11.0	3	Нар.	★	D1100	68	114	11
11.5	3	Нар.	★	D1150	71	118	11.5
12.0	3	Нар.	★	D1200	73	121	12
12.5	3	Нар.	★	D1250	76	135	12.5
13.0	3	Нар.	★	D1300	78	137	13
13.5	3	Нар.	★	D1350	84	144	13.5
14.0	3	Нар.	★	D1400	86	147	14
14.5	3	Нар.	★	D1450	89	151	14.5
15.0	3	Нар.	★	D1500	91	153	15
15.5	3	Нар.	★	D1550	94	157	15.5
16.0	3	Нар.	★	D1600	96	160	16

### РЕКОМЕНДУЕМЫЕ РЕЖИМЫ РЕЗАНИЯ

Обрабатываемый материал	Закалённая Сталь X40CrMoV51, X20Cr13 и т. д. (50–55HRC)		Закалённая сталь Cr12Mo1V1, быстрорежущая сталь с порошковым покрытием и т. д. (55–60 HRC)	
	Частота вращения (мин <sup>-1</sup> )	Подача (мм/об)	Частота вращения (мин <sup>-1</sup> )	Подача (мм/об)
<b>2.5</b>	1900	0.06	1300	0.04
<b>3.0</b>	1600	0.06	1100	0.04
<b>4.0</b>	1200	0.06	800	0.04
<b>5.0</b>	1000	0.06	600	0.04
<b>6.0</b>	800	0.06	530	0.04
<b>8.0</b>	600	0.07	400	0.05
<b>10.0</b>	480	0.07	320	0.05
<b>12.0</b>	400	0.07	270	0.05
<b>14.0</b>	340	0.07	230	0.05
<b>16.0</b>	300	0.07	200	0.05

- 1) Использовать жёсткие станки.
- 2) Рекомендуется использовать цанговый патрон для сохранения состояния хвостовика.
- 3) используйте эмульсию в качестве СОЖ
- 4) Рекомендованная глубина сверления 3D (D: диаметр сверла) на следующих режимах.

# СВЕРЛЕНИЕ (СВЕРЛА СО СМЕННЫМИ ПЛАСТИНАМИ)

## STAW

- Волнистая режущая кромка спроектирована для улучшения контроля за стружкой.
- Очень жёсткая система зажима обеспечивает стабильность и надёжность при сверлении отверстий малого диаметра.

ТВЕРДЫЙ  
СПЛАВ

Углеродистая сталь Легированная сталь	Закалённая сталь	Нержавеющая сталь	Чугун	Лёгкий сплав	Жаропрочные сплавы
◎		○	◎	○	

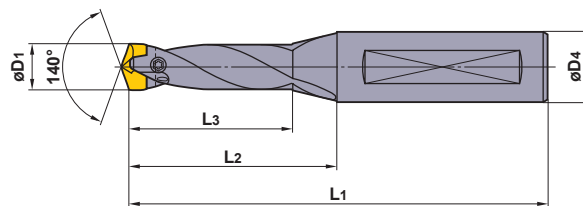

### ДЕРЖАВКА

Диапазон диам. D1 (мм)	Глубина сверления (l/d)	Державка		Пластина		Размеры (мм)				Ключ	
		Обозначение	Наличие	Диам. сверла D1 (мм)	Обозначение	Наличие VP15TF DP5010	L3	L2	L1		D4
10.0   10.4	1.5	STAWSS1000S16	●	10.0	STAWN1000TH	●	22	32	80	16	TIP06F
					STAWK1000TG	●					
	3	STAWSN1000S16	●	10.1	STAWN1010TH	●	37	47	95	16	TIP06F
					STAWK1010TG	●					
	5	STAWMN1000S16	●	10.2	STAWN1020TH	●	57	67	115	16	TIP06F
					STAWK1020TG	●					
8	STAWLN1000S16	●	10.3	STAWN1030TH	●	87	97	145	16	TIP06F	
				STAWK1030TG	●						
			10.4	STAWN1040TH	●						
				STAWK1040TG	●						
10.5   10.9	1.5	STAWSS1050S16	●	10.5	STAWN1050TH	●	22	32	80	16	TIP06F
					STAWK1050TG	●					
	3	STAWSN1050S16	●	10.6	STAWN1060TH	●	37	47	95	16	TIP06F
					STAWK1060TG	●					
	5	STAWMN1050S16	●	10.7	STAWN1070TH	●	57	67	115	16	TIP06F
					STAWK1070TG	●					
8	STAWLN1050S16	●	10.8	STAWN1080TH	●	87	97	145	16	TIP06F	
				STAWK1080TG	●						
			10.9	STAWN1090TH	●						
				STAWK1090TG	●						
11.0   11.4	1.5	STAWSS1100S16	●	11.0	STAWN1100TH	●	25	36	84	16	TIP06F
					STAWK1100TG	●					
	3	STAWSN1100S16	●	11.1	STAWN1110TH	●	41	52	100	16	TIP06F
					STAWK1110TG	●					
	5	STAWMN1100S16	●	11.2	STAWN1120TH	●	66	77	125	16	TIP06F
					STAWK1120TG	●					
8	STAWLN1100S16	●	11.3	STAWN1130TH	●	96	107	155	16	TIP06F	
				STAWK1130TG	●						
			11.4	STAWN1140TH	●						
				STAWK1140TG	●						
11.5   11.9	1.5	STAWSS1150S16	●	11.5	STAWN1150TH	●	25	36	84	16	TIP06F
					STAWK1150TG	●					
	3	STAWSN1150S16	●	11.6	STAWN1160TH	●	41	52	100	16	TIP06F
					STAWK1160TG	●					
	5	STAWMN1150S16	●	11.7	STAWN1170TH	●	66	77	125	16	TIP06F
					STAWK1170TG	●					
8	STAWLN1150S16	●	11.8	STAWN1180TH	●	96	107	155	16	TIP06F	
				STAWK1180TG	●						
			11.9	STAWN1190TH	●						
				STAWK1190TG	●						
12.0   12.4	1.5	STAWSS1200S16	●	12.0	STAWN1200TH	●	27	39	87	16	TIP06F
					STAWK1200TG	●					
	3	STAWSN1200S16	●	12.1	STAWN1210TH	●	45	57	105	16	TIP06F
					STAWK1210TG	●					
	5	STAWMN1200S16	●	12.2	STAWN1220TH	●	70	82	130	16	TIP06F
					STAWK1220TG	●					
8	STAWLN1200S16	●	12.3	STAWN1230TH	●	105	117	165	16	TIP06F	
				STAWK1230TG	●						
			12.4	STAWN1240TH	●						
				STAWK1240TG	●						

(Примечание 1) Вышеуказанные размеры применяются при установке пластины STAWN (VP15TF).

(Примечание 2) Пожалуйста, свяжитесь с нами если Вы не нашли нужную геометрию в данном каталоге (могут быть заказаны другие диаметры и длины).

● : Есть на складе. (Примечание : 1 пластины в наборе)

ОПИСАНИЕ ПЛАСТИН > L118  
 РЕЖИМЫ РЕЗАНИЯ > L122  
 РЕКОМЕНДАЦИИ > L123  
 ТЕХНИЧЕСКИЕ ДАННЫЕ > N001

# СВЕРЛЕНИЕ (СВЕРЛА СО СМЕННЫМИ ПЛАСТИНАМИ)

# STAW

ТВЕРДЫЙ  
СПЛАВ

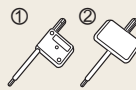
Диапазон диам. D1 (мм)	Глубина сверления l/d	Державка		Пластина			Размеры (мм)				 ① ② Ключ	
		Обозначение	Наличие	Диам. сверла D1 (мм)	Обозначение	Наличие VP15TF DP5010	L3	L2	L1	D4		
12.5   12.9	1.5	STAWSS1250S16	●	12.5	STAWN1250TH	●	27	39	87	16	①TIP06F	
					STAWK1250TG	●						
	3	STAWSN1250S16	●	12.6	STAWN1260TH	●						
												STAWK1260TG
		5	STAWMN1250S16	●	12.7	STAWN1270TH						●
	8	STAWLN1250S16	●	12.8	STAWN1280TH	●						
							STAWK1280TG	●				
				12.9	STAWN1290TH	●						
					STAWK1290TG	●						
13.0   13.4	1.5	STAWSS1300S16	●	13.0	STAWN1300TH	●	30	43	91	16	②TIP08W	
					STAWK1300TG	●						
	3	STAWSN1300S16	●	13.1	STAWN1310TH	●						
												STAWK1310TG
		5	STAWMN1300S16	●	13.2	STAWN1320TH						●
	8	STAWLN1300S16	●	13.3	STAWN1330TH	●						
							STAWK1330TG	●				
				13.4	STAWN1340TH	●						
					STAWK1340TG	●						
13.5   13.9	1.5	STAWSS1350S16	●	13.5	STAWN1350TH	●	30	43	91	16	②TIP08W	
					STAWK1350TG	●						
	3	STAWSN1350S16	●	13.6	STAWN1360TH	●						
												STAWK1360TG
		5	STAWMN1350S16	●	13.7	STAWN1370TH						●
	8	STAWLN1350S16	●	13.8	STAWN1380TH	●						
							STAWK1380TG	●				
				13.9	STAWN1390TH	●						
					STAWK1390TG	●						
14.0   14.4	1.5	STAWSS1400S16	●	14.0	STAWN1400TH	●	31	45	93	16	②TIP08W	
					STAWK1400TG	●						
	3	STAWSN1400S16	●	14.1	STAWN1410TH	●						
												STAWK1410TG
		5	STAWMN1400S16	●	14.2	STAWN1420TH						●
	8	STAWLN1400S16	●	14.3	STAWN1430TH	●						
							STAWK1430TG	●				
				14.4	STAWN1440TH	●						
					STAWK1440TG	●						
14.5   14.9	1.5	STAWSS1450S16	●	14.5	STAWN1450TH	●	31	45	93	16	②TIP08W	
					STAWK1450TG	●						
	3	STAWSN1450S16	●	14.6	STAWN1460TH	●						
												STAWK1460TG
		5	STAWMN1450S16	●	14.7	STAWN1470TH						●
	8	STAWLN1450S16	●	14.8	STAWN1480TH	●						
							STAWK1480TG	●				
				14.9	STAWN1490TH	●						
					STAWK1490TG	●						
15.0   15.4	1.5	STAWSS1500S20	●	15.0	STAWN1500TH	●	33	48	98	20	②TIP08W	
					STAWK1500TG	●						
	3	STAWSN1500S20	●	15.1	STAWN1510TH	●						
												STAWK1510TG
		5	STAWMN1500S20	●	15.2	STAWN1520TH						●
	8	STAWLN1500S20	●	15.3	STAWN1530TH	●						
							STAWK1530TG	●				
				15.4	STAWN1540TH	●						
					STAWK1540TG	●						

(Примечание 1) Вышеуказанные размеры применяются при установке пластины STAWN (VP15TF).

(Примечание 2) Пожалуйста, свяжитесь с нами если Вы не нашли нужную геометрию в данном каталоге (могут быть заказаны другие диаметры и длины).

● : Есть на складе. (Примечание : 1 пластины в наборе)

Диапазон диам. D1 (мм)	Глубина сверления (l/d)	Державка		Пластина			Размеры (мм)				 Ключ
		Обозначение	Наличие	Диам. сверла D1 (мм)	Обозначение	Наличие VP15TF DP5010	L3	L2	L1	D4	
NEW 15.5   16.4	1.5	STAWSS1600S20	●	15.5	STAWN1550T	●	34	50	100	20	TIP10W
					STAWK1550TG	●					
				15.6	STAWN1560T	●					
	3	STAWSN1600S20	●		STAWK1560TG	●	60	80	130	20	TIP10W
				15.7	STAWN1570T	●					
					STAWK1570TG	●					
				15.8	STAWN1580T	●					
					STAWK1580TG	●					
				15.9	STAWN1590T	●					
	5	STAWMN1600S20	●		STAWK1590TG	●	90	115	165	20	TIP10W
				16.0	STAWN1600T	●					
					STAWK1600TG	●					
16.1				STAWN1610T	●						
8	STAWLN1600S20	●		STAWK1610TG	●	138	158	208	20	TIP10W	
			16.2	STAWN1620T	●						
				STAWK1620TG	●						
			16.3	STAWN1630T	●						
				STAWK1630TG	●						
NEW 16.5   17.4	1.5	STAWSS1700S20	●	16.5	STAWN1650T	●	36	53	103	20	TIP10W
					STAWK1650TG	●					
				16.6	STAWN1660T	●					
	3	STAWSN1700S20	●		STAWK1660TG	●	61	85	135	20	TIP10W
				16.7	STAWN1670T	●					
					STAWK1670TG	●					
	5	STAWMN1700S20	●		STAWN1680T	●	95	120	170	20	TIP10W
				16.8	STAWN1680T	●					
					STAWK1680TG	●					
				16.9	STAWN1690T	●					
	8	STAWLN1700S20	●		STAWK1690TG	●	146	166	216	20	TIP10W
				17.0	STAWN1700T	●					
				STAWK1700TG	●						
17.1				STAWN1710T	●						
				STAWK1710TG	●						
NEW 17.5   18.4	1.5	STAWSS1800S20	●	17.5	STAWN1750T	●	37	55	105	20	TIP10W
					STAWK1750TG	●					
				17.6	STAWN1760T	●					
	3	STAWSN1800S20	●		STAWK1760TG	●	64	90	140	20	TIP10W
				17.7	STAWN1770T	●					
					STAWK1770TG	●					
	5	STAWMN1800S20	●		STAWN1780T	●	100	125	175	20	TIP10W
				17.8	STAWN1780T	●					
					STAWK1780TG	●					
				17.9	STAWN1790T	●					
	8	STAWLN1800S20	●		STAWK1790TG	●	154	174	224	20	TIP10W
				18.0	STAWN1800T	●					
				STAWK1800TG	●						
18.1				STAWN1810T	●						
				STAWK1810TG	●						
	18.2	STAWN1820T	●								
		STAWK1820TG	●								
	18.3	STAWN1830T	●								
		STAWK1830TG	●								
	18.4	STAWN1840T	●								
		STAWK1840TG	●								

(Примечание 1) Вышеуказанные размеры применяются при установке пластины STAWN (VP15TF).

(Примечание 2) Пожалуйста, свяжитесь с нами если Вы не нашли нужную геометрию в данном каталоге (могут быть заказаны другие диаметры и длины).

ОПИСАНИЕ ПЛАСТИН > L118  
РЕЖИМЫ РЕЗАНИЯ > L122  
РЕКОМЕНДАЦИИ > L123  
ТЕХНИЧЕСКИЕ ДАННЫЕ > N001

# СВЕРЛЕНИЕ (СВЕРЛА СО СМЕННЫМИ ПЛАСТИНАМИ)

## STAW

ТВЕРДЫЙ  
СПЛАВ

### ПЛАСТИНЫ

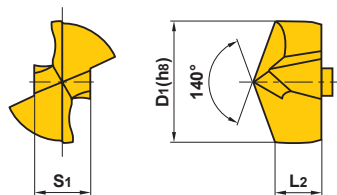

Обозначение	Наличие		Размеры (мм)			Применяемый корпус
	VP15TF		D1	L2	S1	
<b>STAWN1000TH</b>	●		10.0	3.8	4.6	STAWSS1000S16 STAWSN1000S16 STAWMN1000S16 STAWLN1000S16
<b>1010TH</b>	●		10.1	3.8	4.6	
<b>1020TH</b>	●		10.2	3.8	4.6	
<b>1030TH</b>	●		10.3	3.8	4.6	
<b>1040TH</b>	●		10.4	3.8	4.6	
<b>1050TH</b>	●		10.5	4.0	4.8	STAWSS1050S16 STAWSN1050S16 STAWMN1050S16 STAWLN1050S16
<b>1060TH</b>	●		10.6	4.0	4.8	
<b>1070TH</b>	●		10.7	4.0	4.8	
<b>1080TH</b>	●		10.8	4.0	4.8	
<b>1090TH</b>	●		10.9	4.0	4.8	
<b>1100TH</b>	●		11.0	4.2	5.1	STAWSS1100S16 STAWSN1100S16 STAWMN1100S16 STAWLN1100S16
<b>1110TH</b>	●		11.1	4.2	5.1	
<b>1120TH</b>	●		11.2	4.2	5.1	
<b>1130TH</b>	●		11.3	4.2	5.1	
<b>1140TH</b>	●		11.4	4.2	5.1	
<b>1150TH</b>	●		11.5	4.4	5.3	STAWSS1150S16 STAWSN1150S16 STAWMN1150S16 STAWLN1150S16
<b>1160TH</b>	●		11.6	4.4	5.3	
<b>1170TH</b>	●		11.7	4.4	5.3	
<b>1180TH</b>	●		11.8	4.4	5.3	
<b>1190TH</b>	●		11.9	4.4	5.3	
<b>1200TH</b>	●		12.0	4.6	5.5	STAWSS1200S16 STAWSN1200S16 STAWMN1200S16 STAWLN1200S16
<b>1210TH</b>	●		12.1	4.6	5.5	
<b>1220TH</b>	●		12.2	4.6	5.5	
<b>1230TH</b>	●		12.3	4.6	5.5	
<b>1240TH</b>	●		12.4	4.6	5.5	
<b>1250TH</b>	●		12.5	4.8	5.8	STAWSS1250S16 STAWSN1250S16 STAWMN1250S16 STAWLN1250S16
<b>1260TH</b>	●		12.6	4.8	5.8	
<b>1270TH</b>	●		12.7	4.8	5.8	
<b>1280TH</b>	●		12.8	4.8	5.8	
<b>1290TH</b>	●		12.9	4.8	5.8	
<b>1300TH</b>	●		13.0	4.9	6.0	STAWSS1300S16 STAWSN1300S16 STAWMN1300S16 STAWLN1300S16
<b>1310TH</b>	●		13.1	4.9	6.0	
<b>1320TH</b>	●		13.2	4.9	6.0	
<b>1330TH</b>	●		13.3	4.9	6.0	
<b>1340TH</b>	●		13.4	4.9	6.0	
<b>1350TH</b>	●		13.5	5.1	6.2	STAWSS1350S16 STAWSN1350S16 STAWMN1350S16 STAWLN1350S16
<b>1360TH</b>	●		13.6	5.1	6.2	
<b>1370TH</b>	●		13.7	5.1	6.2	
<b>1380TH</b>	●		13.8	5.1	6.2	
<b>1390TH</b>	●		13.9	5.1	6.2	

СВЕРЛЕНИЕ

● : Есть на складе. (Примечание : 1 пластины в наборе)

Обозначение	Наличие		Размеры (мм)			Применяемый корпус
	VP15TF		D1	L2	S1	
<b>STAWN1400TH</b>	●		14.0	5.3	6.4	STAWSS1400S16 STAWSN1400S16 STAWMN1400S16 STAWLN1400S16
<b>1410TH</b>	●		14.1	5.3	6.4	
<b>1420TH</b>	●		14.2	5.3	6.4	
<b>1430TH</b>	●		14.3	5.3	6.4	
<b>1440TH</b>	●		14.4	5.3	6.4	
<b>1450TH</b>	●		14.5	5.5	6.7	STAWSS1450S16 STAWSN1450S16 STAWMN1450S16 STAWLN1450S16
<b>1460TH</b>	●		14.6	5.5	6.7	
<b>1470TH</b>	●		14.7	5.5	6.7	
<b>1480TH</b>	●		14.8	5.5	6.7	
<b>1490TH</b>	●		14.9	5.5	6.7	
<b>1500TH</b>	●		15.0	5.7	6.9	STAWSS1500S20 STAWSN1500S20 STAWMN1500S20 STAWLN1500S20
<b>1510TH</b>	●		15.1	5.7	6.9	
<b>1520TH</b>	●		15.2	5.7	6.9	
<b>1530TH</b>	●		15.3	5.7	6.9	
<b>1540TH</b>	●		15.4	5.7	6.9	
<b>NEW 1550T</b>	●		15.5	5.9	7.1	STAWSS1600S20 STAWSN1600S20 STAWMN1600S20 STAWLN1600S20
<b>NEW 1560T</b>	●		15.6	5.9	7.1	
<b>NEW 1570T</b>	●		15.7	5.9	7.1	
<b>NEW 1580T</b>	●		15.8	5.9	7.1	
<b>NEW 1590T</b>	●		15.9	5.9	7.1	
<b>NEW 1600T</b>	●		16.0	5.9	7.1	
<b>NEW 1610T</b>	●		16.1	5.9	7.1	
<b>NEW 1620T</b>	●		16.2	5.9	7.1	
<b>NEW 1630T</b>	●		16.3	5.9	7.1	
<b>NEW 1640T</b>	●		16.4	5.9	7.1	
<b>NEW 1650T</b>	●		16.5	6.3	7.6	STAWSS1700S20 STAWSN1700S20 STAWMN1700S20 STAWLN1700S20
<b>NEW 1660T</b>	●		16.6	6.3	7.6	
<b>NEW 1670T</b>	●		16.7	6.3	7.6	
<b>NEW 1680T</b>	●		16.8	6.3	7.6	
<b>NEW 1690T</b>	●		16.9	6.3	7.6	
<b>NEW 1700T</b>	●		17.0	6.3	7.6	
<b>NEW 1710T</b>	●		17.1	6.3	7.6	
<b>NEW 1720T</b>	●		17.2	6.3	7.6	
<b>NEW 1730T</b>	●		17.3	6.3	7.6	
<b>NEW 1740T</b>	●		17.4	6.3	7.6	
<b>NEW 1750T</b>	●		17.5	6.7	8.1	STAWSS1800S20 STAWSN1800S20 STAWMN1800S20 STAWLN1800S20
<b>NEW 1760T</b>	●		17.6	6.7	8.1	
<b>NEW 1770T</b>	●		17.7	6.7	8.1	
<b>NEW 1780T</b>	●		17.8	6.7	8.1	
<b>NEW 1790T</b>	●		17.9	6.7	8.1	
<b>NEW 1800T</b>	●		18.0	6.7	8.1	
<b>NEW 1810T</b>	●		18.1	6.7	8.1	
<b>NEW 1820T</b>	●		18.2	6.7	8.1	
<b>NEW 1830T</b>	●		18.3	6.7	8.1	
<b>NEW 1840T</b>	●		18.4	6.7	8.1	

# СВЕРЛЕНИЕ (СВЕРЛА СО СМЕННЫМИ ПЛАСТИНАМИ)

## STAW

### ПЛАСТИНЫ

(Для обработки чугуна)

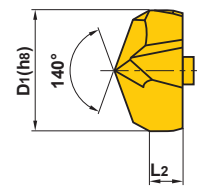

Обозначение	Наличие		Размеры (мм)			Применяемый корпус
	DP5010		D1	L2	S1	
NEW STAWK1000TG	●		10.0	3.3	4.6	STAWSS1000S16 STAWSN1000S16 STAWMN1000S16 STAWLN1000S16
NEW 1010TG	●		10.1	3.3	4.6	
NEW 1020TG	●		10.2	3.3	4.6	
NEW 1030TG	●		10.3	3.3	4.6	
NEW 1040TG	●		10.4	3.3	4.6	
NEW 1050TG	●		10.5	3.5	4.8	STAWSS1050S16 STAWSN1050S16 STAWMN1050S16 STAWLN1050S16
NEW 1060TG	●		10.6	3.5	4.8	
NEW 1070TG	●		10.7	3.5	4.8	
NEW 1080TG	●		10.8	3.5	4.8	
NEW 1090TG	●		10.9	3.5	4.8	
NEW 1100TG	●		11.0	3.7	5.1	STAWSS1100S16 STAWSN1100S16 STAWMN1100S16 STAWLN1100S16
NEW 1110TG	●		11.1	3.7	5.1	
NEW 1120TG	●		11.2	3.7	5.1	
NEW 1130TG	●		11.3	3.7	5.1	
NEW 1140TG	●		11.4	3.7	5.1	
NEW 1150TG	●		11.5	3.9	5.3	STAWSS1150S16 STAWSN1150S16 STAWMN1150S16 STAWLN1150S16
NEW 1160TG	●		11.6	3.9	5.3	
NEW 1170TG	●		11.7	3.9	5.3	
NEW 1180TG	●		11.8	3.9	5.3	
NEW 1190TG	●		11.9	3.9	5.3	
NEW 1200TG	●		12.0	4.1	5.5	STAWSS1200S16 STAWSN1200S16 STAWMN1200S16 STAWLN1200S16
NEW 1210TG	●		12.1	4.1	5.5	
NEW 1220TG	●		12.2	4.1	5.5	
NEW 1230TG	●		12.3	4.1	5.5	
NEW 1240TG	●		12.4	4.1	5.5	
NEW 1250TG	●		12.5	4.2	5.8	STAWSS1250S16 STAWSN1250S16 STAWMN1250S16 STAWLN1250S16
NEW 1260TG	●		12.6	4.2	5.8	
NEW 1270TG	●		12.7	4.2	5.8	
NEW 1280TG	●		12.8	4.2	5.8	
NEW 1290TG	●		12.9	4.2	5.8	
NEW 1300TG	●		13.0	4.4	6.0	STAWSS1300S16 STAWSN1300S16 STAWMN1300S16 STAWLN1300S16
NEW 1310TG	●		13.1	4.4	6.0	
NEW 1320TG	●		13.2	4.4	6.0	
NEW 1330TG	●		13.3	4.4	6.0	
NEW 1340TG	●		13.4	4.4	6.0	
NEW 1350TG	●		13.5	4.6	6.2	STAWSS1350S16 STAWSN1350S16 STAWMN1350S16 STAWLN1350S16
NEW 1360TG	●		13.6	4.6	6.2	
NEW 1370TG	●		13.7	4.6	6.2	
NEW 1380TG	●		13.8	4.6	6.2	
NEW 1390TG	●		13.9	4.6	6.2	

● : Есть на складе. (Примечание : 1 пластины в наборе)

Обозначение	Наличие		Размеры (мм)			Применяемый корпус
	DP5010		D1	L2	S1	
<b>NEW</b> STAWK1400TG	●		14.0	4.8	6.4	STAWSS1400S16 STAWSN1400S16 STAWMN1400S16 STAWLN1400S16
<b>NEW</b> 1410TG	●		14.1	4.8	6.4	
<b>NEW</b> 1420TG	●		14.2	4.8	6.4	
<b>NEW</b> 1430TG	●		14.3	4.8	6.4	
<b>NEW</b> 1440TG	●		14.4	4.8	6.4	
<b>NEW</b> 1450TG	●		14.5	5.0	6.7	STAWSS1450S16 STAWSN1450S16 STAWMN1450S16 STAWLN1450S16
<b>NEW</b> 1460TG	●		14.6	5.0	6.7	
<b>NEW</b> 1470TG	●		14.7	5.0	6.7	
<b>NEW</b> 1480TG	●		14.8	5.0	6.7	
<b>NEW</b> 1490TG	●		14.9	5.0	6.7	
<b>NEW</b> 1500TG	●		15.0	5.2	6.9	STAWSS1500S20 STAWSN1500S20 STAWMN1500S20 STAWLN1500S20
<b>NEW</b> 1510TG	●		15.1	5.2	6.9	
<b>NEW</b> 1520TG	●		15.2	5.2	6.9	
<b>NEW</b> 1530TG	●		15.3	5.2	6.9	
<b>NEW</b> 1540TG	●		15.4	5.2	6.9	
<b>NEW</b> 1550TG	●		15.5	5.3	7.1	STAWSS1600S20 STAWSN1600S20 STAWMN1600S20 STAWLN1600S20
<b>NEW</b> 1560TG	●		15.6	5.3	7.1	
<b>NEW</b> 1570TG	●		15.7	5.3	7.1	
<b>NEW</b> 1580TG	●		15.8	5.3	7.1	
<b>NEW</b> 1590TG	●		15.9	5.3	7.1	
<b>NEW</b> 1600TG	●		16.0	5.3	7.1	
<b>NEW</b> 1610TG	●		16.1	5.3	7.1	
<b>NEW</b> 1620TG	●		16.2	5.3	7.1	
<b>NEW</b> 1630TG	●		16.3	5.3	7.1	
<b>NEW</b> 1640TG	●		16.4	5.3	7.1	
<b>NEW</b> 1650TG	●		16.5	5.7	7.6	STAWSS1700S20 STAWSN1700S20 STAWMN1700S20 STAWLN1700S20
<b>NEW</b> 1660TG	●		16.6	5.7	7.6	
<b>NEW</b> 1670TG	●		16.7	5.7	7.6	
<b>NEW</b> 1680TG	●		16.8	5.7	7.6	
<b>NEW</b> 1690TG	●		16.9	5.7	7.6	
<b>NEW</b> 1700TG	●		17.0	5.7	7.6	
<b>NEW</b> 1710TG	●		17.1	5.7	7.6	
<b>NEW</b> 1720TG	●		17.2	5.7	7.6	
<b>NEW</b> 1730TG	●		17.3	5.7	7.6	
<b>NEW</b> 1740TG	●		17.4	5.7	7.6	
<b>NEW</b> 1750TG	●		17.5	6.0	8.1	STAWSS1800S20 STAWSN1800S20 STAWMN1800S20 STAWLN1800S20
<b>NEW</b> 1760TG	●		17.6	6.0	8.1	
<b>NEW</b> 1770TG	●		17.7	6.0	8.1	
<b>NEW</b> 1780TG	●		17.8	6.0	8.1	
<b>NEW</b> 1790TG	●		17.9	6.0	8.1	
<b>NEW</b> 1800TG	●		18.0	6.0	8.1	
<b>NEW</b> 1810TG	●		18.1	6.0	8.1	
<b>NEW</b> 1820TG	●		18.2	6.0	8.1	
<b>NEW</b> 1830TG	●		18.3	6.0	8.1	
<b>NEW</b> 1840TG	●		18.4	6.0	8.1	

### ШИРИНА ХОНИНГОВАНИЯ

Если требуется не стандартная пластина, а пластина с хонингованием, используйте для заказа нижеприведенные обозначения-символы.

(Стандарт хонингования)

(Номер заказа пластины)

**S T A W N 1 0 0 0 T**

↑  
Название товара  
STAW

↑  
N : Общего применения  
K : Для обработки чугуна

↑  
Диаметр пластины

↑  
Символ  
хонингования

↑  
Тип хонингования

Тип хонингования	Ширина хонингования (мм)
F	0
G	0.02—0.05
H	0.05—0.10
-(Стандарт)	0.10—0.15
K	0.15—0.20
S	0.20—0.25
M	0.25—0.30

### РЕКОМЕНДУЕМЫЕ РЕЖИМЫ РЕЗАНИЯ

Обрабатываемый материал	Диаметр сверла	φ10.0—φ12.9		φ13.0—φ13.9		φ14.0—φ15.4		φ15.5—φ18.4	
		Условия Твердость	Скорость резания (м/мин)	Подача (мм/об)	Скорость резания (м/мин)	Подача (мм/об)	Скорость резания (м/мин)	Подача (мм/об)	Скорость резания (м/мин)
P Малоуглеродистые стали Углеродистая сталь Легированная сталь	≤180НВ	80 (60—100)	0.20 (0.15—0.25)	90 (70—110)	0.25 (0.20—0.30)	100 (80—120)	0.30 (0.25—0.35)	100 (80—120)	0.35 (0.25—0.40)
	180—280НВ	80 (60—100)	0.20 (0.15—0.25)	90 (70—110)	0.25 (0.20—0.30)	100 (80—120)	0.30 (0.25—0.35)	100 (80—120)	0.35 (0.25—0.40)
	280—350НВ	70 (60—90)	0.20 (0.15—0.25)	80 (60—100)	0.25 (0.20—0.30)	90 (70—110)	0.25 (0.20—0.30)	90 (70—110)	0.30 (0.20—0.35)
M Нержавеющая сталь	≤200НВ	40 (30—50)	0.13 (0.10—0.16)	50 (40—60)	0.15 (0.12—0.18)	60 (50—70)	0.17 (0.14—0.20)	60 (50—70)	0.17 (0.14—0.20)
K Чугун Ковкий чугун	Предел прочности ≤350МПа	80 (60—100)	0.20 (0.15—0.25)	90 (70—110)	0.25 (0.20—0.30)	100 (80—120)	0.30 (0.25—0.35)	120 (80—140)	0.45 (0.35—0.55)
	Предел прочности ≤450МПа	70 (60—90)	0.20 (0.15—0.25)	80 (60—100)	0.25 (0.20—0.30)	90 (70—110)	0.30 (0.25—0.35)	100 (80—120)	0.35 (0.25—0.40)

(Примечание 1) При использовании сверла для отверстия глубиной 1,5D можно увеличить скорость подачи приблизительно на 20 %.

(Примечание 2) При использовании державки типа 8D необходимо снизить скорость резания приблизительно на 20 %.

(Примечание 3) При использовании державки типа 8D рекомендуется выполнить направляющее отверстие.

(Примечание 4) Для нержавеющей стали используйте внутреннюю подачу СОЖ

(обработка с масляным туманом и минимальным количеством смазки не рекомендуется).

## ПРИМЕЧАНИЯ К ЭКСПЛУАТАЦИИ

### УСТАНОВКА ПЛАСТИНЫ

- Прежде чем установить сменную пластину в корпус сверла, убедитесь, что отсутствует грязь и посторонние предметы. При необходимости прочистите корпус сверла сжатым воздухом.
- Воспользуйтесь приложенным ключом, чтобы немного отвернуть внутренний винт и ослабить крепление. Затем вставьте сменную пластину в паз корпуса сверла, как показано на рис. 1.  
\*Следите за тем, чтобы ключ при затягивании имел плотный контакт с головкой винта.
- После того как вы установите пластину, затяните внутренний винт и одновременно вдавите пластину в гнездо, как показано на рисунке 2, чтобы она заняла правильное положение и была надежно зафиксирована.  
\*Следите за тем, чтобы ключ при затягивании имел плотный контакт с головкой винта.

Затяните прижимной винт указанным ниже моментом.

Диам. сверла (мм)	Крутящий момент	
	N•м	
10 –12.9	1	
13 –15.4	2	
15.5 –18.4	2.5	

- Убедитесь в том, что между пластиной и корпусом нет зазора.

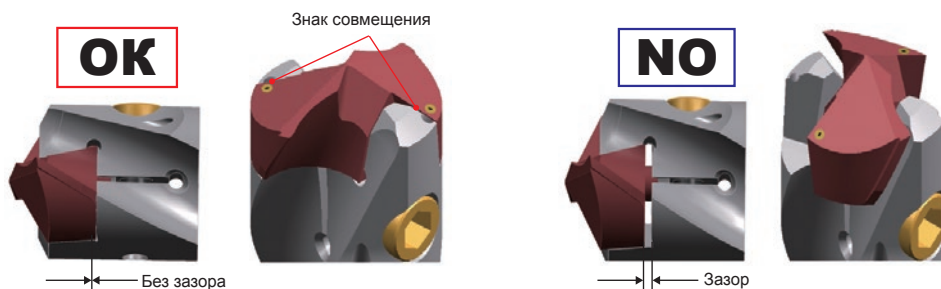

(Примечание) Если внутренний винт недостаточно затянут и пластина установлена неправильно, возможно снижение производительности сверления и/или поломка сверла. Поэтому при установке пластины следите за тем, чтобы знаки совмещения на корпусе и на пластине совпадали. При выполнении работы пользуйтесь средствами защиты.

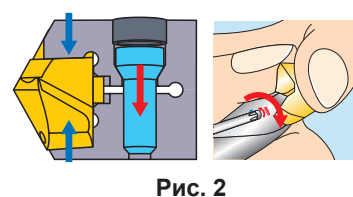
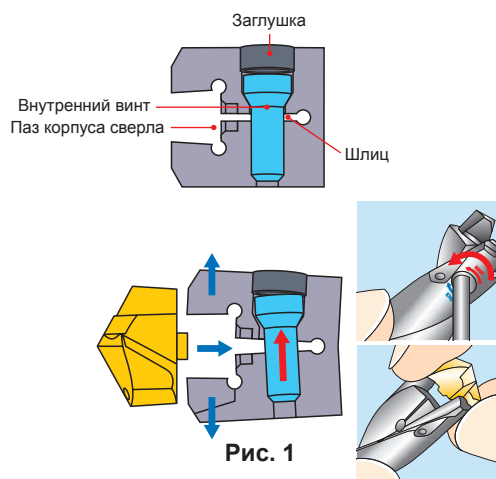

## ЗАПАСНЫЕ ЧАСТИ

Применяемый корпус	Обозначение комплекта (Внутренний винт и заглушка)		
		Внутренний винт	Заглушка
STAWSS/SN/MN/LN1000S16	WS203107TPS-35LH	WS203107TPS	WS35LH
STAWSS/SN/MN/LN1050S16	WS203107TPS-35LH	WS203107TPS	WS35LH
STAWSS/SN/MN/LN1100S16	WS203108TPS-35LH	WS203108TPS	WS35LH
STAWSS/SN/MN/LN1150S16	WS203108TPS-35LH	WS203108TPS	WS35LH
STAWSS/SN/MN/LN1200S16	WS203108TPS-35LH	WS203108TPS	WS35LH
STAWSS/SN/MN/LN1250S16	WS203108TPS-35LH	WS203108TPS	WS35LH
STAWSS/SN/MN/LN1300S16	WS253909TPS-45LH	WS253909TPS	WS45LH
STAWSS/SN/MN/LN1350S16	WS253909TPS-45LH	WS253909TPS	WS45LH
STAWSS/SN/MN/LN1400S16	WS253909TPS-45LH	WS253909TPS	WS45LH
STAWSS/SN/MN/LN1450S16	WS253909TPS-45LH	WS253909TPS	WS45LH
STAWSS/SN/MN/LN1500S20	WS253909TPS-45LH	WS253909TPS	WS45LH
STAWSS/SN/MN/LN1600S20	WS304912TPS-55LH	WS304912TPS	WS55LH
STAWSS/SN/MN/LN1700S20	WS304912TPS-55LH	WS304912TPS	WS55LH
STAWSS/SN/MN/LN1800S20	WS304912TPS-55LH	WS304912TPS	WS55LH

(Примечание) Запасные части комплектуются внутренним винтом, стопорным винтом и руководством по эксплуатации. Пожалуйста, замените все части согласно приложенной инструкции.

# СВЕРЛЕНИЕ (СВЕРЛА СО СМЕННЫМИ ПЛАСТИНАМИ)

ТВЕРДЫЙ  
СПЛАВ

# TAW

- Волнистая режущая кромка спроектирована для улучшения контроля за стружкой.
- Специальные рифления для точной установки пластины.
- Легкая замена пластины.

Углеродистая сталь Легированная сталь	Закалённая сталь	Нержавеющая сталь	Чугун	Лёгкий сплав	Жаропрочные сплавы
◎		○	◎		

(Общего применения)

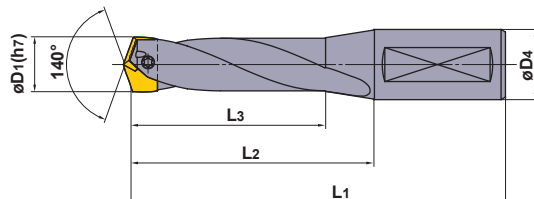

## ДЕРЖАВКА

Диапазон диам. D1 (мм)	Глубина сверления (l/d)	Державка		Пластина			Размеры (мм)				Крепёжный винт	Ключ	Очиститель	Смазка		
		Обозначение	Наличие	Диам. сверла D1 (мм)	Обозначение	Наличие			L3	L2					L1	D4
					VP15TF	DP5010	VP10H									
18.5   19.4	3	TAWSN1900S25	●	18.5	TAWNH1850T	●			68	99	155	25	WS304517T	TKY10T	WPT4405	MK1KS
					TAWKH1850TG		●									
				18.6	TAWNH1860T	●										
					TAWKH1860TG		●									
				18.7	TAWNH1870T	●										
					TAWKH1870TG		●									
	5	TAWMN1900S25	●	18.8	TAWNH1880T	●			107	134	190	25	WS304517T	TKY10T	WPT4405	MK1KS
					TAWKH1880TG		●									
				18.9	TAWNH1890T	●										
					TAWKH1890TG		●									
				19.0	TAWNH1900T	●										
					TAWKH1900TG		●									
8	TAWLN1900S25	●	19.1	TAWNH1910T	●			162	185	241	25	WS304517T	TKY10T	WPT4405	MK1KS	
				TAWKH1910TG		●										
			19.2	TAWNH1920T	●											
				TAWKH1920TG		●										
19.5   20.4	3	TAWSN2000S25	●	19.5	TAWNH1950T	●			72	99	155	25	WS304518T	TKY10T	WPT4405	MK1KS
					TAWKH1950TG		●									
				19.6	TAWNH1960T	●										
					TAWKH1960TG		●									
				19.7	TAWNH1970T	●										
					TAWKH1970TG		●									
	5	TAWMN2000S25	●	19.8	TAWNH1980T	●			113	139	195	25	WS304518T	TKY10T	WPT4405	MK1KS
					TAWKH1980TG		●									
				19.9	TAWNH1990T	●										
					TAWKH1990TG		●									
				20.0	TAWNH2000T	●										
					TAWKH2000TG		●									
8	TAWLN2000S25	●	20.1	TAWNH2010T	□			170	193	249	25	WS304518T	TKY10T	WPT4405	MK1KS	
				TAWKH2010TG		□										
			20.2	TAWNH2020T	□											
				TAWKH2020TG		□										
			20.3	TAWNH2030T	□											
				TAWKH2030TG		□										
20.4	TAWNH2040T	□														
TAWKH2040TG		□														

(Примечание) Пожалуйста, свяжитесь с нами если Вы не нашли нужную геометрию в данном каталоге (могут быть заказаны другие диаметры и длины).

● : Есть на складе. □ : Нет на складе, выпускается исключительно под заказ.

Диапазон диам. D1 (мм)	Глубина сверления (l/d)	Державка		Пластина			Размеры (мм)									
		Обозначение	Наличие	Диам. сверла D1 (мм)	Обозначение	Наличие			L3	L2					L1	D4
						VP15TF	DP5010	VP10H								
20.5   21.4	3	TAWSN2100S25	●	20.5	TAWNH2050T	●			75	99	155	25	WS304518T	TKY10T	WPT4405	MK1KS
					TAWKH2050TG		●									
				20.6	TAWNH2060T	□		□								
					TAWKH2060TG		□									
				20.7	TAWNH2070T	□		□								
					TAWKH2070TG		□									
	5	TAWMN2100S25	●	20.8	TAWNH2080T	□		□	118	139	195	25	WS304518T	TKY10T	WPT4405	MK1KS
					TAWKH2080TG		□									
				20.9	TAWNH2090T	□		□								
					TAWKH2090TG		□									
				21.0	TAWNH2100T	●		□								
					TAWKH2100TG		●									
8	TAWLN2100S25	●	21.1	TAWNH2110T	□		□	178	202	258	25	WS304518T	TKY10T	WPT4405	MK1KS	
				TAWKH2110TG		□										
			21.2	TAWNH2120T	□		□									
				TAWKH2120TG		□										
			21.3	TAWNH2130T	□		□									
				TAWKH2130TG		□										
21.5   22.4	3	TAWSN2200S25	●	21.5	TAWNH2150T	●			79.3	104.3	160.3	25	WS355520T	TKY15T	WPT4405	MK1KS
					TAWKH2150TG		●									
				21.6	TAWNH2160T	□		□								
					TAWKH2160TG		□									
				21.7	TAWNH2170T	□		□								
					TAWKH2170TG		□									
	5	TAWMN2200S25	●	21.8	TAWNH2180T	□		□	124.3	144.3	200.3	25	WS355520T	TKY15T	WPT4405	MK1KS
					TAWKH2180TG		□									
				21.9	TAWNH2190T	□		□								
					TAWKH2190TG		□									
				22.0	TAWNH2200T	●		□								
					TAWKH2200TG		●									
8	TAWLN2200S25	●	22.1	TAWNH2210T	□		□	186	210	266	25	WS355520T	TKY15T	WPT4405	MK1KS	
				TAWKH2210TG		□										
			22.2	TAWNH2220T	□		□									
				TAWKH2220TG		□										
			22.3	TAWNH2230T	□		□									
				TAWKH2230TG		□										
22.5   23.4	3	TAWSN2300S25	●	22.5	TAWNH2250T	●			82.3	104.3	160.3	25	WS355521T	TKY15T	WPT4405	MK1KS
					TAWKH2250TG		●									
				22.6	TAWNH2260T	□		□								
					TAWKH2260TG		□									
				22.7	TAWNH2270T	□		□								
					TAWKH2270TG		□									
	5	TAWMN2300S25	●	22.8	TAWNH2280T	□		□	129.3	154.3	210.3	25	WS355521T	TKY15T	WPT4405	MK1KS
					TAWKH2280TG		□									
				22.9	TAWNH2290T	□		□								
					TAWKH2290TG		□									
				23.0	TAWNH2300T	●		□								
					TAWKH2300TG		●									
8	TAWLN2300S25	●	23.1	TAWNH2310T	□		□	194	223	279	25	WS355521T	TKY15T	WPT4405	MK1KS	
				TAWKH2310TG		□										
			23.2	TAWNH2320T	□		□									
				TAWKH2320TG		□										
			23.3	TAWNH2330T	□		□									
				TAWKH2330TG		□										
	23.4	TAWNH2340T	□		□											
		TAWKH2340TG		□												

# СВЕРЛЕНИЕ (СВЕРЛА СО СМЕННЫМИ ПЛАСТИНАМИ)

# TAW

ТВЕРДЫЙ  
СПЛАВ

Диапазон диам. D1 (мм)	Глубина сверления (l/d)	Державка		Пластина			Размеры (мм)									
		Обозначение	Наличие	Диам. сверла D1 (мм)	Обозначение	Наличие			L3	L2					L1	D4
					VP15TF	DP5010	VP10H									
23.5   24.4	3	TAWSN2400S32	●	23.5	TAWNH2350T	●			86.3	110.3	170.3	32	WS355521T	TKY15T	WPT4405	MK1KS
					TAWKH2350TG		●									
				23.6	TAWNH2360T	□		□								
					TAWKH2360TG		□									
				23.7	TAWNH2370T	□		□								
					TAWKH2370TG		□									
	5	TAWMN2400S32	●	23.8	TAWNH2380T	□		□	135.3	160.3	220.3	32	WS355521T	TKY15T	WPT4405	MK1KS
					TAWKH2380TG		□									
				23.9	TAWNH2390T	□		□								
					TAWKH2390TG		□									
				24.0	TAWNH2400T	●		□								
					TAWKH2400TG		●									
8	TAWLN2400S32	●	24.1	TAWNH2410T	□		□	202	232	292	32	WS355521T	TKY15T	WPT4405	MK1KS	
				TAWKH2410TG		□										
			24.2	TAWNH2420T	□		□									
				TAWKH2420TG		□										
			24.3	TAWNH2430T	□		□									
				TAWKH2430TG		□										
24.5   25.4	3	TAWSN2500S32	●	24.5	TAWNH2450T	●			88.6	110.6	170.6	32	WS406023T	TKY25T	WPT4405	MK1KS
					TAWKH2450TG		●									
				24.6	TAWNH2460T	□		□								
					TAWKH2460TG		□									
				24.7	TAWNH2470T	□		□								
					TAWKH2470TG		□									
	5	TAWMN2500S32	●	24.8	TAWNH2480T	□		□	140.6	165.6	225.6	32	WS406023T	TKY25T	WPT4405	MK1KS
					TAWKH2480TG		□									
				24.9	TAWNH2490T	□		□								
					TAWKH2490TG		□									
				25.0	TAWNH2500T	●		□								
					TAWKH2500TG		●									
8	TAWLN2500S32	●	25.1	TAWNH2510T	□		□	210	240	300	32	WS406023T	TKY25T	WPT4405	MK1KS	
				TAWKH2510TG		□										
			25.2	TAWNH2520T	□		□									
				TAWKH2520TG		□										
			25.3	TAWNH2530T	□		□									
				TAWKH2530TG		□										
25.5   26.4	3	TAWSN2600S32	●	25.5	TAWNH2550T	●			92.6	115.6	175.6	32	WS406024T	TKY25T	WPT4405	MK1KS
					TAWKH2550TG		●									
				25.6	TAWNH2560T	□		□								
					TAWKH2560TG		□									
				25.7	TAWNH2570T	□		□								
					TAWKH2570TG		□									
	5	TAWMN2600S32	●	25.8	TAWNH2580T	□		□	146.6	170.6	230.6	32	WS406024T	TKY25T	WPT4405	MK1KS
					TAWKH2580TG		□									
				25.9	TAWNH2590T	□		□								
					TAWKH2590TG		□									
				26.0	TAWNH2600T	●		□								
					TAWKH2600TG		●									
8	TAWLN2600S32	●	26.1	TAWNH2610T	□		□	218	248	308	32	WS406024T	TKY25T	WPT4405	MK1KS	
				TAWKH2610TG		□										
			26.2	TAWNH2620T	□		□									
				TAWKH2620TG		□										
			26.3	TAWNH2630T	□		□									
				TAWKH2630TG		□										
	26.4	TAWNH2640T	□		□											
		TAWKH2640TG		□												

(Примечание) Пожалуйста, свяжитесь с нами если Вы не нашли нужную геометрию в данном каталоге (могут быть заказаны другие диаметры и длины).

● : Есть на складе. □ : Нет на складе, выпускается исключительно под заказ.

Диапазон диам. D1 (мм)	Глубина сверления (l/d)	Державка		Пластина			Размеры (мм)										
		Обозначение	Наличие	Диам. сверла D1 (мм)	Обозначение	Наличие			L3	L2					L1	D4	
						VP15TF	DP5010	VP10H									
(мм)	(l/d)																
26.5   27.4	3	TAWSN2700S32	●	26.5	TAWNH2650T	●			94.6	115.6	175.6	32	WS406024T	TKY25T	WPT4405	MK1KS	
					TAWKH2650TG		●										
				26.6	TAWNH2660T	□		□									
					TAWKH2660TG		□										
				26.7	TAWNH2670T	□		□									
					TAWKH2670TG		□										
	5	TAWMN2700S32	●	26.8	TAWNH2680T	□		□	151.6	175.6	235.6	32	WS406024T	TKY25T	WPT4405	MK1KS	
					TAWKH2680TG		□										
				26.9	TAWNH2690T	□		□									
					TAWKH2690TG		□										
				27.0	TAWNH2700T	●		□									
					TAWKH2700TG		●										
8	TAWLN2700S32	●	27.1	TAWNH2710T	□		□	226	256	316	32	WS406024T	TKY25T	WPT4405	MK1KS		
				TAWKH2710TG		□											
			27.2	TAWNH2720T	□		□										
				TAWKH2720TG		□											
			27.3	TAWNH2730T	□		□										
				TAWKH2730TG		□											
27.5   28.4	3	TAWSN2800S32	●	27.5	TAWNH2750T	●			97.2	120.2	180.2	32	WS508026T	TKY27T	WPT4405	MK1KS	
					TAWKH2750TG		●										
				27.6	TAWNH2760T	□		□									
					TAWKH2760TG		□										
				27.7	TAWNH2770T	□		□									
					TAWKH2770TG		□										
	5	TAWMN2800S32	●	27.8	TAWNH2780T	□		□	157.2	180.2	240.2	32	WS508026T	TKY27T	WPT4405	MK1KS	
					TAWKH2780TG		□										
				27.9	TAWNH2790T	□		□									
					TAWKH2790TG		□										
				28.0	TAWNH2800T	●		□									
					TAWKH2800TG		●										
8	TAWLN2800S32	●	28.1	TAWNH2810T	□		□	234	264	324	32	WS508026T	TKY27T	WPT4405	MK1KS		
				TAWKH2810TG		□											
			28.2	TAWNH2820T	□		□										
				TAWKH2820TG		□											
			28.3	TAWNH2830T	□		□										
				TAWKH2830TG		□											
28.5   29.4	3	TAWSN2900S32	●	28.5	TAWNH2850T	●			100.2	125.2	185.2	32	WS508027T	TKY27T	WPT4405	MK1KS	
					TAWKH2850TG		●										
				28.6	TAWNH2860T	□		□									
					TAWKH2860TG		□										
				28.7	TAWNH2870T	□		□									
					TAWKH2870TG		□										
	5	TAWMN2900S32	●	28.8	TAWNH2880T	□		□	162.2	185.2	245.2	32	WS508027T	TKY27T	WPT4405	MK1KS	
					TAWKH2880TG		□										
				28.9	TAWNH2890T	□		□									
					TAWKH2890TG		□										
				29.0	TAWNH2900T	●		□									
					TAWKH2900TG		●										
8	TAWLN2900S32	●	29.1	TAWNH2910T	□		□	242	272	332	32	WS508027T	TKY27T	WPT4405	MK1KS		
				TAWKH2910TG		□											
			29.2	TAWNH2920T	□		□										
				TAWKH2920TG		□											
			29.3	TAWNH2930T	□		□										
				TAWKH2930TG		□											
	29.4	TAWNH2940T	□		□												
		TAWKH2940TG		□													

# СВЕРЛЕНИЕ (СВЕРЛА СО СМЕННЫМИ ПЛАСТИНАМИ)

# TAW

ТВЕРДЫЙ  
СПЛАВ

Диапазон диам. D1 (мм)	Глубина сверления (l/d)	Державка		Пластина			Размеры (мм)									
		Обозначение	Наличие	Диам. сверла D1 (мм)	Обозначение	Наличие			L3	L2					L1	D4
						VP15TF	DP5010	VP10H								
29.5   30.4	3	TAWSN3000S32	●	29.5	TAWNH2950T	●			104.2	125.2	185.2	32	WS508027T	TKY27T	WPT4405	МК1KS
					TAWKH2950TG		●									
				29.6	TAWNH2960T	□		□								
					TAWKH2960TG		□									
				29.7	TAWNH2970T	□		□								
					TAWKH2970TG		□									
	5	TAWMN3000S32	●	29.8	TAWNH2980T	□		□	167.2	195.2	255.2	32	WS508027T	TKY27T	WPT4405	МК1KS
					TAWKH2980TG		□									
				29.9	TAWNH2990T	□		□								
					TAWKH2990TG		□									
				30.0	TAWNH3000T	●		□								
					TAWKH3000TG		●									
	8	TAWLN3000S32	●	30.1	TAWNH3010T	□		□	250	285	345	32	WS508027T	TKY27T	WPT4405	МК1KS
					TAWKH3010TG		□									
30.2				TAWNH3020T	□		□									
				TAWKH3020TG		□										
30.3				TAWNH3030T	□		□									
				TAWKH3030TG		□										
	30.4	TAWNH3040T	□		□											
		TAWKH3040TG		□												

(Примечание) Пожалуйста, свяжитесь с нами если Вы не нашли нужную геометрию в данном каталоге (могут быть заказаны другие диаметры и длины).

СВЕРЛЕНИЕ

● : Есть на складе. (Примечание : 1 пластины в наборе)  
□ : Нет на складе, выпускается исключительно под заказ.

L128

Заказ инструмента: <http://steelcam.org> | 8 (343) 382-52-03 | [sales@sverla-ekb.ru](mailto:sales@sverla-ekb.ru)

## ПЛАСТИНЫ

Тип Н

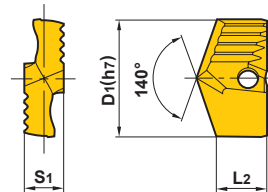
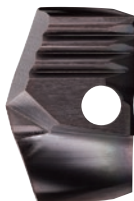

Обозначение	Наличие		Размеры (мм)			Применяемый корпус
	VP15TF	VP10H	D1	L2	S1	
<b>TAWNH1850T</b>	●	□	18.5	9.3	7.0	TAWSN 1900S25
<b>1860T</b>	●	□	18.6	9.3	7.0	
<b>1870T</b>	●	□	18.7	9.3	7.0	
<b>1880T</b>	●	□	18.8	9.3	7.0	
<b>1890T</b>	●	□	18.9	9.3	7.0	
<b>1900T</b>	●	□	19.0	9.2	7.0	
<b>1910T</b>	●	□	19.1	9.2	7.0	
<b>1920T</b>	●	□	19.2	9.2	7.0	
<b>1930T</b>	●	□	19.3	9.2	7.0	
<b>1940T</b>	●	□	19.4	9.2	7.0	
<b>1950T</b>	●	□	19.5	9.1	7.0	TAWSN 2000S25
<b>1960T</b>	●	□	19.6	9.1	7.0	
<b>1970T</b>	●	□	19.7	9.1	7.0	
<b>1980T</b>	●	□	19.8	9.1	7.0	
<b>1990T</b>	●	□	19.9	9.1	7.0	
<b>2000T</b>	●	□	20.0	9.0	7.0	
<b>2010T</b>	□	□	20.1	9.0	7.0	
<b>2020T</b>	□	□	20.2	9.0	7.0	
<b>2030T</b>	□	□	20.3	9.0	7.0	
<b>2040T</b>	□	□	20.4	9.0	7.0	
<b>2050T</b>	●	□	20.5	8.9	7.0	TAWSN 2100S25
<b>2060T</b>	□	□	20.6	8.9	7.0	
<b>2070T</b>	□	□	20.7	8.9	7.0	
<b>2080T</b>	□	□	20.8	8.9	7.0	
<b>2090T</b>	□	□	20.9	8.9	7.0	
<b>2100T</b>	●	□	21.0	8.8	7.0	
<b>2110T</b>	□	□	21.1	8.8	7.0	
<b>2120T</b>	□	□	21.2	8.8	7.0	
<b>2130T</b>	□	□	21.3	8.8	7.0	
<b>2140T</b>	□	□	21.4	8.8	7.0	
<b>2150T</b>	●	□	21.5	10.6	8.0	TAWSN 2200S25
<b>2160T</b>	□	□	21.6	10.6	8.0	
<b>2170T</b>	□	□	21.7	10.6	8.0	
<b>2180T</b>	□	□	21.8	10.6	8.0	
<b>2190T</b>	□	□	21.9	10.6	8.0	
<b>2200T</b>	●	□	22.0	10.5	8.0	
<b>2210T</b>	□	□	22.1	10.5	8.0	
<b>2220T</b>	□	□	22.2	10.5	8.0	
<b>2230T</b>	□	□	22.3	10.5	8.0	
<b>2240T</b>	□	□	22.4	10.5	8.0	

Обозначение	Наличие		Размеры (мм)			Применяемый корпус
	VP15TF	VP10H	D1	L2	S1	
<b>TAWNH2250T</b>	●	□	22.5	10.4	8.0	TAWSN 2300S25
<b>2260T</b>	□	□	22.6	10.4	8.0	
<b>2270T</b>	□	□	22.7	10.4	8.0	
<b>2280T</b>	□	□	22.8	10.4	8.0	
<b>2290T</b>	□	□	22.9	10.4	8.0	
<b>2300T</b>	●	□	23.0	10.3	8.0	
<b>2310T</b>	□	□	23.1	10.3	8.0	
<b>2320T</b>	□	□	23.2	10.3	8.0	
<b>2330T</b>	□	□	23.3	10.3	8.0	
<b>2340T</b>	□	□	23.4	10.3	8.0	
<b>2350T</b>	●	□	23.5	10.2	8.0	TAWSN 2400S32
<b>2360T</b>	□	□	23.6	10.2	8.0	
<b>2370T</b>	□	□	23.7	10.2	8.0	
<b>2380T</b>	□	□	23.8	10.2	8.0	
<b>2390T</b>	□	□	23.9	10.2	8.0	
<b>2400T</b>	●	□	24.0	10.1	8.0	
<b>2410T</b>	□	□	24.1	10.1	8.0	
<b>2420T</b>	□	□	24.2	10.1	8.0	
<b>2430T</b>	□	□	24.3	10.1	8.0	
<b>2440T</b>	□	□	24.4	10.1	8.0	
<b>2450T</b>	●	□	24.5	11.7	9.0	TAWSN 2500S32
<b>2460T</b>	□	□	24.6	11.7	9.0	
<b>2470T</b>	□	□	24.7	11.7	9.0	
<b>2480T</b>	□	□	24.8	11.7	9.0	
<b>2490T</b>	□	□	24.9	11.7	9.0	
<b>2500T</b>	●	□	25.0	11.6	9.0	
<b>2510T</b>	□	□	25.1	11.6	9.0	
<b>2520T</b>	□	□	25.2	11.6	9.0	
<b>2530T</b>	□	□	25.3	11.6	9.0	
<b>2540T</b>	□	□	25.4	11.6	9.0	
<b>2550T</b>	●	□	25.5	11.5	9.0	TAWSN 2600S32
<b>2560T</b>	□	□	25.6	11.5	9.0	
<b>2570T</b>	□	□	25.7	11.5	9.0	
<b>2580T</b>	□	□	25.8	11.5	9.0	
<b>2590T</b>	□	□	25.9	11.5	9.0	
<b>2600T</b>	●	□	26.0	11.4	9.0	
<b>2610T</b>	□	□	26.1	11.4	9.0	
<b>2620T</b>	□	□	26.2	11.4	9.0	
<b>2630T</b>	□	□	26.3	11.4	9.0	
<b>2640T</b>	□	□	26.4	11.4	9.0	

СВЕРЛЕНИЕ

РЕЖИМЫ РЕЗАНИЯ > L133  
РЕКОМЕНДАЦИИ > L134  
ТЕХНИЧЕСКИЕ ДАННЫЕ > N001

# СВЕРЛЕНИЕ (СВЕРЛА СО СМЕННЫМИ ПЛАСТИНАМИ)

# TAW

ТВЕРДЫЙ  
СПЛАВ

Обозначение	Наличие		Размеры (мм)			Применяемый корпус
	VP15TF	VP10H	D1	L2	S1	
<b>TAWNH2650T</b>	●	□	26.5	11.3	9.0	
<b>2660T</b>	□	□	26.6	11.3	9.0	
<b>2670T</b>	□	□	26.7	11.3	9.0	TAWSN
<b>2680T</b>	□	□	26.8	11.3	9.0	2700S32
<b>2690T</b>	□	□	26.9	11.3	9.0	TAWMN
<b>2700T</b>	●	□	27.0	11.2	9.0	2700S32
<b>2710T</b>	□	□	27.1	11.2	9.0	TAWLN
<b>2720T</b>	□	□	27.2	11.2	9.0	2700S32
<b>2730T</b>	□	□	27.3	11.2	9.0	
<b>2740T</b>	□	□	27.4	11.2	9.0	
<b>2750T</b>	●	□	27.5	12.3	10.0	
<b>2760T</b>	□	□	27.6	12.3	10.0	
<b>2770T</b>	□	□	27.7	12.3	10.0	TAWSN
<b>2780T</b>	□	□	27.8	12.3	10.0	2800S32
<b>2790T</b>	□	□	27.9	12.3	10.0	TAWMN
<b>2800T</b>	●	□	28.0	12.2	10.0	2800S32
<b>2810T</b>	□	□	28.1	12.2	10.0	TAWLN
<b>2820T</b>	□	□	28.2	12.2	10.0	2800S32
<b>2830T</b>	□	□	28.3	12.2	10.0	
<b>2840T</b>	□	□	28.4	12.2	10.0	
<b>2850T</b>	●	□	28.5	12.1	10.0	
<b>2860T</b>	□	□	28.6	12.1	10.0	
<b>2870T</b>	□	□	28.7	12.1	10.0	TAWSN
<b>2880T</b>	□	□	28.8	12.1	10.0	2900S32
<b>2890T</b>	□	□	28.9	12.1	10.0	TAWMN
<b>2900T</b>	●	□	29.0	12.0	10.0	2900S32
<b>2910T</b>	□	□	29.1	12.0	10.0	TAWLN
<b>2920T</b>	□	□	29.2	12.0	10.0	2900S32
<b>2930T</b>	□	□	29.3	12.0	10.0	
<b>2940T</b>	□	□	29.4	12.0	10.0	
<b>2950T</b>	●	□	29.5	11.9	10.0	
<b>2960T</b>	□	□	29.6	11.9	10.0	
<b>2970T</b>	□	□	29.7	11.9	10.0	TAWSN
<b>2980T</b>	□	□	29.8	11.9	10.0	3000S32
<b>2990T</b>	□	□	29.9	11.9	10.0	TAWMN
<b>3000T</b>	●	□	30.0	11.8	10.0	3000S32
<b>3010T</b>	□	□	30.1	11.8	10.0	TAWLN
<b>3020T</b>	□	□	30.2	11.8	10.0	3000S32
<b>3030T</b>	□	□	30.3	11.8	10.0	
<b>3040T</b>	□	□	30.4	11.8	10.0	

СВЕРЛЕНИЕ

● : Есть на складе. (Примечание : 1 пластины в наборе)

□ : Нет на складе, выпускается исключительно под заказ.

## ПЛАСТИНЫ

Тип Н  
(Для обработки чугуна)

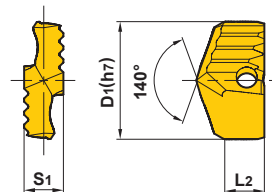

Обозначение	Наличие DP5010	Размеры (мм)			Применяемый корпус
		D1	L2	S1	
<b>TAWKH1850TG</b>	●	18.5	8.6	7.0	TAWSN 1900S25
<b>1860TG</b>	●	18.6	8.6	7.0	
<b>1870TG</b>	●	18.7	8.6	7.0	
<b>1880TG</b>	●	18.8	8.6	7.0	
<b>1890TG</b>	●	18.9	8.6	7.0	
<b>1900TG</b>	●	19.0	8.5	7.0	
<b>1910TG</b>	●	19.1	8.5	7.0	
<b>1920TG</b>	●	19.2	8.5	7.0	
<b>1930TG</b>	●	19.3	8.5	7.0	
<b>1940TG</b>	●	19.4	8.5	7.0	
<b>1950TG</b>	●	19.5	8.4	7.0	TAWSN 2000S25
<b>1960TG</b>	●	19.6	8.4	7.0	
<b>1970TG</b>	●	19.7	8.4	7.0	
<b>1980TG</b>	●	19.8	8.4	7.0	
<b>1990TG</b>	●	19.9	8.4	7.0	
<b>2000TG</b>	●	20.0	8.3	7.0	
<b>2010TG</b>	□	20.1	8.3	7.0	
<b>2020TG</b>	□	20.2	8.3	7.0	
<b>2030TG</b>	□	20.3	8.3	7.0	
<b>2040TG</b>	□	20.4	8.3	7.0	
<b>2050TG</b>	●	20.5	8.2	7.0	TAWSN 2100S25
<b>2060TG</b>	□	20.6	8.2	7.0	
<b>2070TG</b>	□	20.7	8.2	7.0	
<b>2080TG</b>	□	20.8	8.2	7.0	
<b>2090TG</b>	□	20.9	8.2	7.0	
<b>2100TG</b>	●	21.0	8.1	7.0	
<b>2110TG</b>	□	21.1	8.1	7.0	
<b>2120TG</b>	□	21.2	8.1	7.0	
<b>2130TG</b>	□	21.3	8.1	7.0	
<b>2140TG</b>	□	21.4	8.1	7.0	
<b>2150TG</b>	●	21.5	9.8	8.0	TAWSN 2200S25
<b>2160TG</b>	□	21.6	9.8	8.0	
<b>2170TG</b>	□	21.7	9.8	8.0	
<b>2180TG</b>	□	21.8	9.8	8.0	
<b>2190TG</b>	□	21.9	9.8	8.0	
<b>2200TG</b>	●	22.0	9.7	8.0	
<b>2210TG</b>	□	22.1	9.7	8.0	
<b>2220TG</b>	□	22.2	9.7	8.0	
<b>2230TG</b>	□	22.3	9.7	8.0	
<b>2240TG</b>	□	22.4	9.7	8.0	

Обозначение	Наличие DP5010	Размеры (мм)			Применяемый корпус
		D1	L2	S1	
<b>TAWKH2250TG</b>	●	22.5	9.6	8.0	TAWSN 2300S25
<b>2260TG</b>	□	22.6	9.6	8.0	
<b>2270TG</b>	□	22.7	9.6	8.0	
<b>2280TG</b>	□	22.8	9.6	8.0	
<b>2290TG</b>	□	22.9	9.6	8.0	
<b>2300TG</b>	●	23.0	9.5	8.0	
<b>2310TG</b>	□	23.1	9.5	8.0	
<b>2320TG</b>	□	23.2	9.5	8.0	
<b>2330TG</b>	□	23.3	9.5	8.0	
<b>2340TG</b>	□	23.4	9.5	8.0	
<b>2350TG</b>	●	23.5	9.4	8.0	TAWSN 2400S32
<b>2360TG</b>	□	23.6	9.4	8.0	
<b>2370TG</b>	□	23.7	9.4	8.0	
<b>2380TG</b>	□	23.8	9.4	8.0	
<b>2390TG</b>	□	23.9	9.4	8.0	
<b>2400TG</b>	●	24.0	9.3	8.0	
<b>2410TG</b>	□	24.1	9.3	8.0	
<b>2420TG</b>	□	24.2	9.3	8.0	
<b>2430TG</b>	□	24.3	9.3	8.0	
<b>2440TG</b>	□	24.4	9.3	8.0	
<b>2450TG</b>	●	24.5	10.8	9.0	TAWSN 2500S32
<b>2460TG</b>	□	24.6	10.8	9.0	
<b>2470TG</b>	□	24.7	10.8	9.0	
<b>2480TG</b>	□	24.8	10.8	9.0	
<b>2490TG</b>	□	24.9	10.8	9.0	
<b>2500TG</b>	●	25.0	10.7	9.0	
<b>2510TG</b>	□	25.1	10.7	9.0	
<b>2520TG</b>	□	25.2	10.7	9.0	
<b>2530TG</b>	□	25.3	10.7	9.0	
<b>2540TG</b>	□	25.4	10.7	9.0	
<b>2550TG</b>	●	25.5	10.6	9.0	TAWSN 2600S32
<b>2560TG</b>	□	25.6	10.6	9.0	
<b>2570TG</b>	□	25.7	10.6	9.0	
<b>2580TG</b>	□	25.8	10.6	9.0	
<b>2590TG</b>	□	25.9	10.6	9.0	
<b>2600TG</b>	●	26.0	10.5	9.0	
<b>2610TG</b>	□	26.1	10.5	9.0	
<b>2620TG</b>	□	26.2	10.5	9.0	
<b>2630TG</b>	□	26.3	10.5	9.0	
<b>2640TG</b>	□	26.4	10.5	9.0	

РЕЖИМЫ РЕЗАНИЯ > L133  
РЕКОМЕНДАЦИИ > L134  
ТЕХНИЧЕСКИЕ ДАННЫЕ > N001

# СВЕРЛЕНИЕ (СВЕРЛА СО СМЕННЫМИ ПЛАСТИНАМИ)

# TAW

ТВЕРДЫЙ  
СПЛАВ

Обозначение	Наличие DP6010	Размеры (мм)			Применяемый корпус
		D1	L2	S1	
<b>TAWKH2650TG</b>	●	26.5	10.4	9.0	TAWSN 2700S32
<b>2660TG</b>	□	26.6	10.4	9.0	
<b>2670TG</b>	□	26.7	10.4	9.0	
<b>2680TG</b>	□	26.8	10.4	9.0	
<b>2690TG</b>	□	26.9	10.4	9.0	
<b>2700TG</b>	●	27.0	10.3	9.0	
<b>2710TG</b>	□	27.1	10.3	9.0	
<b>2720TG</b>	□	27.2	10.3	9.0	
<b>2730TG</b>	□	27.3	10.3	9.0	
<b>2740TG</b>	□	27.4	10.3	9.0	
<b>2750TG</b>	●	27.5	11.3	10.0	TAWSN 2800S32
<b>2760TG</b>	□	27.6	11.3	10.0	
<b>2770TG</b>	□	27.7	11.3	10.0	
<b>2780TG</b>	□	27.8	11.3	10.0	
<b>2790TG</b>	□	27.9	11.3	10.0	
<b>2800TG</b>	●	28.0	11.2	10.0	
<b>2810TG</b>	□	28.1	11.2	10.0	
<b>2820TG</b>	□	28.2	11.2	10.0	
<b>2830TG</b>	□	28.3	11.2	10.0	
<b>2840TG</b>	□	28.4	11.2	10.0	
<b>2850TG</b>	●	28.5	11.1	10.0	TAWSN 2900S32
<b>2860TG</b>	□	28.6	11.1	10.0	
<b>2870TG</b>	□	28.7	11.1	10.0	
<b>2880TG</b>	□	28.8	11.1	10.0	
<b>2890TG</b>	□	28.9	11.1	10.0	
<b>2900TG</b>	●	29.0	11.0	10.0	
<b>2910TG</b>	□	29.1	11.0	10.0	
<b>2920TG</b>	□	29.2	11.0	10.0	
<b>2930TG</b>	□	29.3	11.0	10.0	
<b>2940TG</b>	□	29.4	11.0	10.0	
<b>2950TG</b>	●	29.5	10.9	10.0	TAWSN 3000S32
<b>2960TG</b>	□	29.6	10.9	10.0	
<b>2970TG</b>	□	29.7	10.9	10.0	
<b>2980TG</b>	□	29.8	10.9	10.0	
<b>2990TG</b>	□	29.9	10.9	10.0	
<b>3000TG</b>	●	30.0	10.8	10.0	
<b>3010TG</b>	□	30.1	10.8	10.0	
<b>3020TG</b>	□	30.2	10.8	10.0	
<b>3030TG</b>	□	30.3	10.8	10.0	
<b>3040TG</b>	□	30.4	10.8	10.0	

СВЕРЛЕНИЕ

● : Есть на складе. (Примечание : 1 пластины в наборе)

□ : Нет на складе, выпускается исключительно под заказ.

## РЕКОМЕНДУЕМЫЕ РЕЖИМЫ РЕЗАНИЯ

Обрабатываемый материал	Диаметр сверла	φ 14.0—φ 15.4		φ 15.5—φ 18.4		φ 18.5—φ 21.4	
		Условия Твердость	Скорость резания (м/мин)	Подача (мм/об)	Скорость резания (м/мин)	Подача (мм/об)	Скорость резания (м/мин)
<b>P</b> Малоуглеродистые стали	≤180НВ	70 (60—90)	0.20 (0.15—0.25)	80 (60—100)	0.25 (0.20—0.30)	90 (70—110)	0.25 (0.20—0.30)
	180—280НВ	70 (60—90)	0.20 (0.15—0.25)	80 (60—100)	0.25 (0.20—0.30)	80 (60—100)	0.25 (0.20—0.30)
Углеродистая сталь Легированная сталь	280—350НВ	60 (50—80)	0.15 (0.12—0.18)	70 (50—90)	0.20 (0.15—0.25)	70 (50—90)	0.20 (0.15—0.25)
	≤200НВ	50 (40—60)	0.15 (0.12—0.18)	50 (40—60)	0.15 (0.12—0.18)	60 (50—70)	0.20 (0.15—0.22)
<b>M</b> Нержавеющая сталь	≤200НВ	50 (40—60)	0.15 (0.12—0.18)	50 (40—60)	0.15 (0.12—0.18)	60 (50—70)	0.20 (0.15—0.22)
<b>K</b> Чугун	Предел прочности ≤350МПа	70 (50—90)	0.20 (0.15—0.25)	100 (60—120)	0.25 (0.20—0.30)	120 (60—140)	0.25 (0.20—0.30)
	Предел прочности ≤450МПа	70 (50—90)	0.20 (0.15—0.25)	80 (60—90)	0.25 (0.20—0.30)	80 (60—90)	0.25 (0.20—0.30)
Ковкий чугун	Предел прочности ≤450МПа	70 (50—90)	0.20 (0.15—0.25)	80 (60—90)	0.25 (0.20—0.30)	80 (60—90)	0.25 (0.20—0.30)

Обрабатываемый материал	Диаметр сверла	φ 21.5—φ 24.4		φ 24.5—φ 27.4		φ 27.5—φ 30.4	
		Условия Твердость	Скорость резания (м/мин)	Подача (мм/об)	Скорость резания (м/мин)	Подача (мм/об)	Скорость резания (м/мин)
<b>P</b> Малоуглеродистые стали	≤180НВ	100 (80—120)	0.30 (0.25—0.35)	110 (80—120)	0.30 (0.25—0.35)	110 (80—120)	0.30 (0.25—0.35)
	180—280НВ	90 (70—110)	0.30 (0.25—0.35)	100 (80—120)	0.30 (0.25—0.35)	100 (80—120)	0.30 (0.25—0.35)
Углеродистая сталь Легированная сталь	280—350НВ	80 (60—100)	0.25 (0.20—0.30)	90 (70—110)	0.25 (0.20—0.30)	90 (70—110)	0.25 (0.20—0.30)
	≤200НВ	60 (50—70)	0.20 (0.15—0.22)	70 (60—80)	0.25 (0.20—0.28)	70 (60—80)	0.25 (0.20—0.28)
<b>M</b> Нержавеющая сталь	≤200НВ	60 (50—70)	0.20 (0.15—0.22)	70 (60—80)	0.25 (0.20—0.28)	70 (60—80)	0.25 (0.20—0.28)
<b>K</b> Чугун	Предел прочности ≤350МПа	130 (80—150)	0.35 (0.25—0.40)	140 (90—160)	0.35 (0.25—0.40)	140 (90—160)	0.40 (0.30—0.45)
	Предел прочности ≤450МПа	90 (60—100)	0.30 (0.25—0.35)	100 (80—110)	0.30 (0.25—0.35)	100 (80—110)	0.30 (0.25—0.35)
Ковкий чугун	Предел прочности ≤450МПа	90 (60—100)	0.30 (0.25—0.35)	100 (80—110)	0.30 (0.25—0.35)	100 (80—110)	0.30 (0.25—0.35)

(Примечание 1) Для обработки низкоуглеродистой и нержавеющей стали мы рекомендуем использовать хонингование типа Н.

(Примечание 2) Рекомендовано для использования только при высокой жесткости станка и крепления. Используйте систему внутреннего охлаждения при обработке нержавеющей стали. (Не рекомендуется обработка с масляным туманом).

## ШИРИНА ХОНИНГОВАНИЯ

Если требуется не стандартная пластина, а пластина с хонингованием, используйте для заказа нижеприведенные обозначения-символы.

(Номер заказа пластины)



(Стандарт хонингования)

Тип хонингования	Ширина хонингования (мм)
F	0
G	0.02—0.05
H	0.05—0.10
-(Стандарт)	0.10—0.15
K	0.15—0.20
S	0.20—0.25
M	0.25—0.30

Затяните прижимной винт указанным ниже моментом.

Диам. сверла	Крутящий момент
φ14—φ15	2.0N•м
φ16—φ18	2.0N•м
φ19—φ21	3.5N•м
φ22—φ24	5.5N•м
φ25—φ27	8.5N•м
φ28—φ30	12.0N•м

## ПРИМЕЧАНИЯ К ЭКСПЛУАТАЦИИ

### УСТАНОВКА ПЛАСТИНЫ

- Удалите крепежный винт, чтобы установить пластину (тип пластины - Н).
- Ослабьте прижимной винт вставленной пластины (Тип пластины U).
- Поправьте зацепление зубчатых частей пластины и корпуса, затем сдвиньте пластину к дну паза на корпусе.
- Удерживая пластину, как показано на рис. 1, быстро заверните зажимной винт прилагаемым ключом.
- Проверьте отсутствие зазора между пластиной и корпусом. (Рис. 2)



Рис. 1



OK

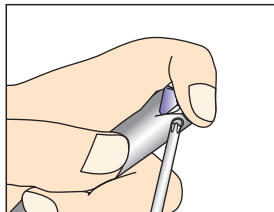
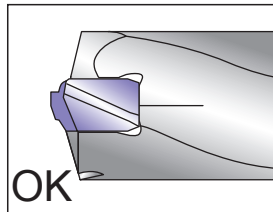
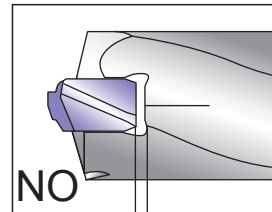

NO

Рис. 2

Зазор

### ЗАМЕНА ПЛАСТИНЫ

- Перед установкой новой пластины предварительно очистите зубчатое зацепление корпуса. Окончательно удалите грязь в зубчатом зацеплении корпуса прилагаемым шаблоном.

Углеродистая сталь Легированная сталь	Закалённая сталь	Нержавеющая сталь	Чугун	Лёгкий сплав	Жаропрочные сплавы
◎		○	◎		

	Допуск на мех. обработку (мм)
L/D=2-3	+ 0.25 0.00
L/D=4-5	+ 0.35 0.00
L/D=6	+ 0.45 0.00

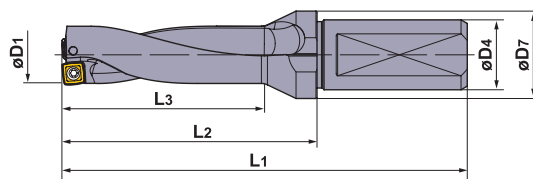
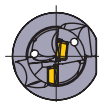

Затяните прижимной винт указанным ниже моментом.

Диам. сверла	Крутящий момент
Ø17-Ø19.5	1.0N•м
Ø20-Ø27.5	2.0N•м
Ø28-Ø33	3.5N•м



Диаметр D1 (мм)	Глубина отверстия (l/d)	Обозначение	Наличие Зубья	Размеры (мм)					Максимальная радиальная регулировка (мм)	Пластина	Винт	Ключ	
				L3	L2	L1	D4	D7					
17.0	2	MVX1700X2F20	●	2	41	56	99	20	25	0.5	SOMX063005-UM	TPS25	TIP07F
	3	1700X3F20	●	2	58	73	116	20	25	0.5	063005-UM	TPS25	TIP07F
	4	1700X4F20	●	2	75	90	133	20	25	0.5	063005-UM	TPS25	TIP07F
	5	1700X5F20	●	2	92	107	150	20	25	0.5	063005-UM	TPS25	TIP07F
	6	1700X6F20	●	2	109	124	167	20	25	0.5	063005-UM	TPS25	TIP07F
17.5	2	1750X2F25	●	2	42	62	112	25	32	0.45	063005-UM	TPS25	TIP07F
	3	1750X3F25	●	2	59.5	79.5	129.5	25	32	0.45	063005-UM	TPS25	TIP07F
	4	1750X4F25	●	2	77	97	147	25	32	0.45	063005-UM	TPS25	TIP07F
	5	1750X5F25	●	2	94.5	114.5	164.5	25	32	0.45	063005-UM	TPS25	TIP07F
	6	1750X6F25	●	2	112	132	182	25	32	0.45	063005-UM	TPS25	TIP07F
18.0	2	1800X2F25	●	2	43	63	113	25	32	0.4	063005-UM	TPS25	TIP07F
	3	1800X3F25	●	2	61	81	131	25	32	0.4	063005-UM	TPS25	TIP07F
	4	1800X4F25	●	2	79	99	149	25	32	0.4	063005-UM	TPS25	TIP07F
	5	1800X5F25	●	2	97	117	167	25	32	0.4	063005-UM	TPS25	TIP07F
	6	1800X6F25	●	2	115	135	185	25	32	0.4	063005-UM	TPS25	TIP07F
18.5	2	1850X2F25	●	2	44	64	114	25	32	0.35	063005-UM	TPS25	TIP07F
	3	1850X3F25	●	2	62.5	82.5	132.5	25	32	0.35	063005-UM	TPS25	TIP07F
	4	1850X4F25	●	2	81	101	151	25	32	0.35	063005-UM	TPS25	TIP07F
	5	1850X5F25	●	2	99.5	119.5	169.5	25	32	0.35	063005-UM	TPS25	TIP07F
	6	1850X6F25	●	2	118	138	188	25	32	0.35	063005-UM	TPS25	TIP07F
19.0	2	1900X2F25	●	2	45	65	115	25	32	0.3	063005-UM	TPS25	TIP07F
	3	1900X3F25	●	2	64	84	134	25	32	0.3	063005-UM	TPS25	TIP07F
	4	1900X4F25	●	2	83	103	153	25	32	0.3	063005-UM	TPS25	TIP07F
	5	1900X5F25	●	2	102	122	172	25	32	0.3	063005-UM	TPS25	TIP07F
	6	1900X6F25	●	2	121	141	191	25	32	0.3	063005-UM	TPS25	TIP07F
19.5	2	1950X2F25	●	2	46	66	116	25	32	0.25	063005-UM	TPS25	TIP07F
	3	1950X3F25	●	2	65.5	85.5	135.5	25	32	0.25	063005-UM	TPS25	TIP07F
	4	1950X4F25	●	2	85	105	155	25	32	0.25	063005-UM	TPS25	TIP07F
	5	1950X5F25	●	2	104.5	124.5	174.5	25	32	0.25	063005-UM	TPS25	TIP07F
	6	1950X6F25	●	2	124	144	194	25	32	0.25	063005-UM	TPS25	TIP07F
20.0	2	2000X2F25	●	2	47	67	117	25	32	0.6	073505-UM	TPS3	TIP10F
	3	2000X3F25	●	2	67	87	137	25	32	0.6	073505-UM	TPS3	TIP10F
	4	2000X4F25	●	2	87	107	157	25	32	0.6	073505-UM	TPS3	TIP10F
	5	2000X5F25	●	2	107	127	177	25	32	0.6	073505-UM	TPS3	TIP10F
	6	2000X6F25	●	2	127	147	197	25	32	0.6	073505-UM	TPS3	TIP10F
20.5	2	2050X2F25	●	2	48	68	118	25	32	0.55	073505-UM	TPS3	TIP10F
	3	2050X3F25	●	2	68.5	88.5	138.5	25	32	0.55	073505-UM	TPS3	TIP10F

● : Есть на складе. (Примечание : 1 пластины в наборе)



# СВЕРЛЕНИЕ (СВЕРЛА СО СМЕННЫМИ ПЛАСТИНАМИ)

**MVX** **NEW**

ТВЕРДЫЙ  
СПЛАВ

Диаметр D1 (мм)	Глубина отверстия (l/d)	Обозначение	Наличие	Зубья	Размеры (мм)					Максимальная радиальная регулировка (мм)	Пластина		
					L3	L2	L1	D4	D7				
21.0	2	MVX2100X2F25	●	2	49	69	119	25	32	0.5	SOMX073505-UM	TPS3	TIP10F
	3	2100X3F25	●	2	70	90	140	25	32	0.5	073505-UM	TPS3	TIP10F
	4	2100X4F25	●	2	91	111	161	25	32	0.5	073505-UM	TPS3	TIP10F
	5	2100X5F25	●	2	112	132	182	25	32	0.5	073505-UM	TPS3	TIP10F
	6	2100X6F25	●	2	133	153	203	25	32	0.5	073505-UM	TPS3	TIP10F
21.5	2	2150X2F25	●	2	50	70	120	25	32	0.45	073505-UM	TPS3	TIP10F
	3	2150X3F25	●	2	71.5	91.5	141.5	25	32	0.45	073505-UM	TPS3	TIP10F
22.0	2	2200X2F25	●	2	51	71	121	25	32	0.4	073505-UM	TPS3	TIP10F
	3	2200X3F25	●	2	73	93	143	25	32	0.4	073505-UM	TPS3	TIP10F
	4	2200X4F25	●	2	95	115	165	25	32	0.4	073505-UM	TPS3	TIP10F
	5	2200X5F25	●	2	117	137	187	25	32	0.4	073505-UM	TPS3	TIP10F
	6	2200X6F25	●	2	139	159	209	25	32	0.4	073505-UM	TPS3	TIP10F
22.5	2	2250X2F25	●	2	52	72	122	25	32	0.35	073505-UM	TPS3	TIP10F
	3	2250X3F25	●	2	74.5	94.5	144.5	25	32	0.35	073505-UM	TPS3	TIP10F
23.0	2	2300X2F25	●	2	53	73	123	25	32	0.8	084005-UM	TPS351	TIP10F
	3	2300X3F25	●	2	76	96	146	25	32	0.8	084005-UM	TPS351	TIP10F
	4	2300X4F25	●	2	99	119	169	25	32	0.8	084005-UM	TPS351	TIP10F
	5	2300X5F25	●	2	122	142	192	25	32	0.8	084005-UM	TPS351	TIP10F
	6	2300X6F25	●	2	145	165	215	25	32	0.8	084005-UM	TPS351	TIP10F
23.5	2	2350X2F25	●	2	54	74	124	25	32	0.75	084005-UM	TPS351	TIP10F
	3	2350X3F25	●	2	77.5	97.5	147.5	25	32	0.75	084005-UM	TPS351	TIP10F
24.0	2	2400X2F25	●	2	55	75	125	25	32	0.7	084005-UM	TPS351	TIP10F
	3	2400X3F25	●	2	79	99	149	25	32	0.7	084005-UM	TPS351	TIP10F
	4	2400X4F25	●	2	103	123	173	25	32	0.7	084005-UM	TPS351	TIP10F
	5	2400X5F25	●	2	127	147	197	25	32	0.7	084005-UM	TPS351	TIP10F
	6	2400X6F25	●	2	151	171	221	25	32	0.7	084005-UM	TPS351	TIP10F
24.5	2	2450X2F25	●	2	56	76	126	25	32	0.65	084005-UM	TPS351	TIP10F
	3	2450X3F25	●	2	80.5	100.5	150.5	25	32	0.65	084005-UM	TPS351	TIP10F
25.0	2	2500X2F25	●	2	57	77	127	25	32	0.6	084005-UM	TPS351	TIP10F
	3	2500X3F25	●	2	82	102	152	25	32	0.6	084005-UM	TPS351	TIP10F
	4	2500X4F25	●	2	107	127	177	25	32	0.6	084005-UM	TPS351	TIP10F
	5	2500X5F25	●	2	132	152	202	25	32	0.6	084005-UM	TPS351	TIP10F
	6	2500X6F25	●	2	157	177	227	25	32	0.6	084005-UM	TPS351	TIP10F
25.5	2	2550X2F25	●	2	58	78	128	25	32	0.6	084005-UM	TPS351	TIP10F
	3	2550X3F25	●	2	83.5	103.5	153.5	25	32	0.6	084005-UM	TPS351	TIP10F
26.0	2	2600X2F32	●	2	59	79	134	32	42	0.5	084005-UM	TPS351	TIP10F
	3	2600X3F32	●	2	85	105	160	32	42	0.5	084005-UM	TPS351	TIP10F
	4	2600X4F32	●	2	111	131	186	32	42	0.5	084005-UM	TPS351	TIP10F
	5	2600X5F32	●	2	137	157	212	32	42	0.5	084005-UM	TPS351	TIP10F
	6	2600X6F32	●	2	163	183	238	32	42	0.5	084005-UM	TPS351	TIP10F
26.5	2	2650X2F32	●	2	60	80	135	32	42	0.5	084005-UM	TPS351	TIP10F
	3	2650X3F32	●	2	86.5	106.5	161.5	32	42	0.5	084005-UM	TPS351	TIP10F
27.0	2	2700X2F32	●	2	61	81	136	32	42	0.45	084005-UM	TPS351	TIP10F
	3	2700X3F32	●	2	88	108	163	32	42	0.45	084005-UM	TPS351	TIP10F
	4	2700X4F32	●	2	115	135	190	32	42	0.45	084005-UM	TPS351	TIP10F
	5	2700X5F32	●	2	142	162	217	32	42	0.45	084005-UM	TPS351	TIP10F
	6	2700X6F32	●	2	169	189	244	32	42	0.45	084005-UM	TPS351	TIP10F
27.5	2	2750X2F32	●	2	62	82	137	32	42	0.4	084005-UM	TPS351	TIP10F
	3	2750X3F32	●	2	89.5	109.5	164.5	32	42	0.4	084005-UM	TPS351	TIP10F
28.0	2	2800X2F32	●	2	63	83	138	32	42	0.85	094506-UM	TPS4	TIP15W
	3	2800X3F32	●	2	91	111	166	32	42	0.85	094506-UM	TPS4	TIP15W
	4	2800X4F32	●	2	119	139	194	32	42	0.85	094506-UM	TPS4	TIP15W
	5	2800X5F32	●	2	147	167	222	32	42	0.85	094506-UM	TPS4	TIP15W
	6	2800X6F32	●	2	175	195	250	32	42	0.85	094506-UM	TPS4	TIP15W

СВЕРЛЕНИЕ

Диаметр D1 (mm)	Глубина отверстия (l/d)	Обозначение	Наличие Зубья	Размеры (мм)					Максимальная радиальная регулировка (мм)	Пластина			
				L3	L2	L1	D4	D7					
28.5	2	MVX2850X2F32	●	2	64	84	139	32	42	0.8	SOMX094506-UM	TPS4	TIP15W
	3	2850X3F32	●	2	92.5	112.5	167.5	32	42	0.8	094506-UM	TPS4	TIP15W
29.0	2	2900X2F32	●	2	65	85	140	32	42	0.75	094506-UM	TPS4	TIP15W
	3	2900X3F32	●	2	94	114	169	32	42	0.75	094506-UM	TPS4	TIP15W
	4	2900X4F32	●	2	123	143	198	32	42	0.75	094506-UM	TPS4	TIP15W
	5	2900X5F32	●	2	152	172	227	32	42	0.75	094506-UM	TPS4	TIP15W
	6	2900X6F32	●	2	181	201	256	32	42	0.75	094506-UM	TPS4	TIP15W
29.5	2	2950X2F32	●	2	66	86	141	32	42	0.7	094506-UM	TPS4	TIP15W
	3	2950X3F32	●	2	95.5	115.5	170.5	32	42	0.7	094506-UM	TPS4	TIP15W
30.0	2	3000X2F32	●	2	67	87	142	32	42	0.65	094506-UM	TPS4	TIP15W
	3	3000X3F32	●	2	97	117	172	32	42	0.65	094506-UM	TPS4	TIP15W
	4	3000X4F32	●	2	127	147	202	32	42	0.65	094506-UM	TPS4	TIP15W
	5	3000X5F32	●	2	157	177	232	32	42	0.65	094506-UM	TPS4	TIP15W
	6	3000X6F32	●	2	187	207	262	32	42	0.65	094506-UM	TPS4	TIP15W
30.5	3	3050X3F32	●	2	98.5	118.5	173.5	32	42	0.6	094506-UM	TPS4	TIP15W
31.0	2	3100X2F32	●	2	69	89	144	32	42	0.55	094506-UM	TPS4	TIP15W
	3	3100X3F32	●	2	100	120	175	32	42	0.55	094506-UM	TPS4	TIP15W
	4	3100X4F32	●	2	131	151	206	32	42	0.55	094506-UM	TPS4	TIP15W
	2	3100X2F40	●	2	69	89	154	40	50	0.55	094506-UM	TPS4	TIP15W
	3	3100X3F40	●	2	100	120	185	40	50	0.55	094506-UM	TPS4	TIP15W
	4	3100X4F40	●	2	131	151	216	40	50	0.55	094506-UM	TPS4	TIP15W
	5	3100X5F40	●	2	162	182	247	40	50	0.55	094506-UM	TPS4	TIP15W
	6	3100X6F40	●	2	193	213	278	40	50	0.55	094506-UM	TPS4	TIP15W
31.5	3	3150X3F40	●	2	101.5	121.5	186.5	40	50	0.55	094506-UM	TPS4	TIP15W
32.0	2	3200X2F32	●	2	71	91	146	32	42	0.45	094506-UM	TPS4	TIP15W
	3	3200X3F32	●	2	103	123	178	32	42	0.45	094506-UM	TPS4	TIP15W
	4	3200X4F32	●	2	135	155	210	32	42	0.45	094506-UM	TPS4	TIP15W
	2	3200X2F40	●	2	71	91	156	40	50	0.45	094506-UM	TPS4	TIP15W
	3	3200X3F40	●	2	103	123	188	40	50	0.45	094506-UM	TPS4	TIP15W
	4	3200X4F40	●	2	135	155	220	40	50	0.45	094506-UM	TPS4	TIP15W
	5	3200X5F40	●	2	167	187	252	40	50	0.45	094506-UM	TPS4	TIP15W
	6	3200X6F40	●	2	199	219	284	40	50	0.45	094506-UM	TPS4	TIP15W
32.5	3	3250X3F40	●	2	104.5	124.5	189.5	40	50	0.45	094506-UM	TPS4	TIP15W
33.0	2	3300X2F32	●	2	73	93	148	32	42	0.4	094506-UM	TPS4	TIP15W
	3	3300X3F32	●	2	106	126	181	32	42	0.4	094506-UM	TPS4	TIP15W
	4	3300X4F32	●	2	139	159	214	32	42	0.4	094506-UM	TPS4	TIP15W
	2	3300X2F40	●	2	73	93	158	40	50	0.4	094506-UM	TPS4	TIP15W
	3	3300X3F40	●	2	106	126	191	40	50	0.4	094506-UM	TPS4	TIP15W
	4	3300X4F40	●	2	139	159	224	40	50	0.4	094506-UM	TPS4	TIP15W
	5	3300X5F40	●	2	172	192	257	40	50	0.4	094506-UM	TPS4	TIP15W
	6	3300X6F40	●	2	205	225	290	40	50	0.4	094506-UM	TPS4	TIP15W

СВЕРЛЕНИЕ

ПЛАСТИНЫ

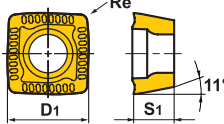
Стружколом	Диаметр сверления	Номер пластины	Размеры (мм)			Сплав			Геометрия
			D1	S1	Re	VP15TF	MC1020	MC5020	
 Общего применения	Ø17—Ø19.5	SOMX063005-UM	6	3	0.5	●	●	●	
	Ø20—Ø22.5	073505-UM	7	3.5	0.5	●	●	●	
	Ø23—Ø27.5	084005-UM	8.3	4	0.5	●	●	●	
	Ø28—Ø33	094506-UM	9.7	4.5	0.6	●	●	●	

\*MC1020 и MC5020 предназначены исключительно для использования в качестве внешней пластины.

# СВЕРЛЕНИЕ (СВЕРЛА СО СМЕННЫМИ ПЛАСТИНАМИ)



ТВЕРДЫЙ  
СПЛАВ

## РЕКОМЕНДУЕМЫЕ РЕЖИМЫ РЕЗАНИЯ

Обрабатываемый материал	Твердость	Сплав		φ17—φ19.5				φ20—φ23.5			
				Vc (м/мин)	f (мм/об)			Vc (м/мин)	f (мм/об)		
		Внешн.	Внутренний		l/d=2—6	l/d=2, 3	l/d=4, 5		l/d=6	l/d=2—6	l/d=2, 3
<b>P</b> Низкоуглеродистая сталь (C15, Ck15)	≤180HB	<b>MC1020</b>	<b>VP15TF</b>	200 (180—235)	0.05 (0.04—0.06)	0.05 (0.04—0.06)	0.04 (0.04—0.05)	200 (180—235)	0.06 (0.04—0.08)	0.06 (0.04—0.07)	0.04 (0.04—0.05)
	180—280HB	<b>MC1020</b>	<b>VP15TF</b>	140 (115—180)	0.08 (0.06—0.14)	0.08 (0.06—0.09)	0.05 (0.04—0.06)	140 (115—180)	0.10 (0.06—0.18)	0.09 (0.06—0.12)	0.07 (0.06—0.08)
	280—350HB	<b>MC1020</b>	<b>VP15TF</b>	100 (75—140)	0.08 (0.06—0.14)	0.08 (0.06—0.09)	0.05 (0.04—0.06)	100 (75—140)	0.10 (0.06—0.18)	0.09 (0.06—0.12)	0.07 (0.06—0.08)
	≤350HB	<b>MC1020</b>	<b>VP15TF</b>	135 (100—170)	0.08 (0.06—0.14)	0.08 (0.06—0.09)	0.05 (0.04—0.06)	135 (100—170)	0.10 (0.06—0.18)	0.09 (0.06—0.12)	0.07 (0.06—0.08)
<b>M</b> Нержавеющая аустенитная сталь (X5CrNi189, X5CrNiMo1810)	≤200HB	<b>MC1020</b>	<b>VP15TF</b>	140 (115—180)	0.06 (0.04—0.08)	0.05 (0.04—0.06)	0.04 (0.04—0.05)	140 (115—180)	0.08 (0.06—0.12)	0.07 (0.06—0.08)	0.06 (0.06—0.07)
	>200HB	<b>MC1020</b>	<b>VP15TF</b>	140 (115—180)	0.06 (0.04—0.08)	0.05 (0.04—0.06)	0.04 (0.04—0.05)	140 (115—180)	0.08 (0.06—0.12)	0.07 (0.06—0.08)	0.06 (0.06—0.07)
	≤200HB	<b>MC1020</b>	<b>VP15TF</b>	140 (115—165)	0.06 (0.04—0.08)	0.05 (0.04—0.06)	0.04 (0.04—0.05)	140 (115—165)	0.09 (0.06—0.14)	0.07 (0.06—0.09)	0.06 (0.06—0.07)
	>200HB	<b>MC1020</b>	<b>VP15TF</b>	140 (115—165)	0.06 (0.04—0.08)	0.05 (0.04—0.06)	0.04 (0.04—0.05)	140 (115—165)	0.09 (0.06—0.14)	0.07 (0.06—0.09)	0.06 (0.06—0.07)
<b>K</b> Чугун (GG25, GG30)	≤350MPa	<b>MC5020</b>	<b>VP15TF</b>	160 (130—195)	0.11 (0.08—0.14)	0.09 (0.08—0.10)	0.05 (0.04—0.06)	160 (130—195)	0.14 (0.10—0.18)	0.10 (0.10—0.12)	0.07 (0.06—0.08)
	≤450MPa	<b>MC5020</b>	<b>VP15TF</b>	100 (80—135)	0.11 (0.08—0.14)	0.09 (0.08—0.10)	0.05 (0.04—0.06)	100 (80—135)	0.13 (0.10—0.16)	0.10 (0.10—0.11)	0.07 (0.06—0.08)
	≤800MPa	<b>MC5020</b>	<b>VP15TF</b>	100 (70—125)	0.11 (0.08—0.14)	0.09 (0.08—0.10)	0.05 (0.04—0.06)	100 (70—125)	0.13 (0.10—0.16)	0.10 (0.10—0.11)	0.07 (0.06—0.08)

Обрабатываемый материал	Твердость	Сплав		φ24—φ29.5				φ30—φ33			
				Vc (м/мин)	f (мм/об)			Vc (м/мин)	f (мм/об)		
		Внешн.	Внутренний		l/d=2—6	l/d=2, 3	l/d=4, 5		l/d=6	l/d=2—6	l/d=2, 3
<b>P</b> Низкоуглеродистая сталь (C15, Ck15)	≤180HB	<b>MC1020</b>	<b>VP15TF</b>	200 (180—235)	0.07 (0.04—0.08)	0.06 (0.04—0.07)	0.05 (0.04—0.06)	200 (180—235)	0.08 (0.06—0.10)	0.07 (0.06—0.08)	0.06 (0.06—0.07)
	180—280HB	<b>MC1020</b>	<b>VP15TF</b>	140 (115—180)	0.12 (0.08—0.18)	0.10 (0.08—0.12)	0.09 (0.08—0.10)	140 (115—180)	0.14 (0.08—0.24)	0.12 (0.08—0.16)	0.11 (0.10—0.12)
	280—350HB	<b>MC1020</b>	<b>VP15TF</b>	100 (75—140)	0.12 (0.08—0.18)	0.10 (0.08—0.12)	0.09 (0.08—0.10)	100 (75—140)	0.14 (0.08—0.24)	0.12 (0.08—0.16)	0.11 (0.10—0.12)
	≤350HB	<b>MC1020</b>	<b>VP15TF</b>	135 (100—170)	0.12 (0.08—0.18)	0.10 (0.08—0.12)	0.09 (0.08—0.10)	135 (100—170)	0.14 (0.08—0.24)	0.12 (0.08—0.16)	0.10 (0.08—0.12)
<b>M</b> Нержавеющая аустенитная сталь (X5CrNi189, X5CrNiMo1810)	≤200HB	<b>MC1020</b>	<b>VP15TF</b>	140 (115—180)	0.09 (0.06—0.12)	0.08 (0.06—0.09)	0.07 (0.06—0.08)	140 (115—180)	0.11 (0.06—0.16)	0.08 (0.06—0.11)	0.07 (0.06—0.10)
	>200HB	<b>MC1020</b>	<b>VP15TF</b>	140 (115—180)	0.09 (0.06—0.12)	0.08 (0.06—0.09)	0.07 (0.06—0.08)	140 (115—180)	0.11 (0.06—0.16)	0.08 (0.06—0.11)	0.07 (0.06—0.10)
	≤200HB	<b>MC1020</b>	<b>VP15TF</b>	140 (115—165)	0.10 (0.06—0.14)	0.08 (0.06—0.09)	0.07 (0.06—0.08)	140 (115—165)	0.11 (0.06—0.16)	0.09 (0.06—0.11)	0.08 (0.06—0.10)
	>200HB	<b>MC1020</b>	<b>VP15TF</b>	140 (115—165)	0.10 (0.06—0.14)	0.08 (0.06—0.09)	0.07 (0.06—0.08)	140 (115—165)	0.11 (0.06—0.16)	0.09 (0.06—0.11)	0.08 (0.06—0.10)
<b>K</b> Чугун (GG25, GG30)	≤350MPa	<b>MC5020</b>	<b>VP15TF</b>	160 (130—195)	0.15 (0.10—0.20)	0.11 (0.10—0.13)	0.09 (0.08—0.10)	160 (130—195)	0.15 (0.10—0.20)	0.12 (0.10—0.13)	0.11 (0.10—0.12)
	≤450MPa	<b>MC5020</b>	<b>VP15TF</b>	100 (80—135)	0.14 (0.10—0.18)	0.11 (0.10—0.12)	0.09 (0.08—0.10)	100 (80—135)	0.15 (0.10—0.20)	0.12 (0.10—0.13)	0.11 (0.10—0.12)
	≤800MPa	<b>MC5020</b>	<b>VP15TF</b>	100 (70—125)	0.14 (0.10—0.18)	0.11 (0.10—0.12)	0.09 (0.08—0.10)	100 (70—125)	0.15 (0.10—0.20)	0.12 (0.10—0.13)	0.11 (0.10—0.12)

- 1) Уменьшите скорость резания на 30% при использовании VP15TF в качестве внешней пластины.
- 2) L/D=3 — рекомендованная максимальная глубина резания при использовании только наружной подачи СОЖ.
- 3) Внутренняя подача СОЖ необходима при сверлении нержавеющей стали.

# TAFS, TAFM, TAFL

ТВЕРДЫЙ  
СПЛАВ

Углеродистая сталь Легированная сталь	Закалённая сталь	Нержавеющая сталь	Чугун	Лёгкий сплав	Жаропрочные сплавы
○		○	○		

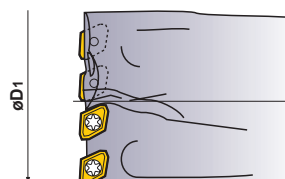
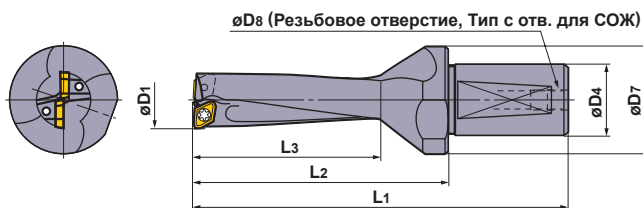

Число зубьев = 4 (D1 ≥ 49)

\* Резьбовое отверстие для винта в области фланца не предназначено для подачи СОЖ.

Диаметр сверла D1 (мм)	Глубина сверления (l/d)	Обозначение	Наличие	Число зубьев	Размеры (мм)						Обозначение пластины	Крепёжный винт	Ключ
					D4	D7	D8	L1	L2	L3			
12.0	2	TAFS1200F20	●	2	20	25	PT1/8	82	39	29	GCMT040204-U	TS2	ТКУ06F
	3	TAFM1200F20	●	2	20	25	PT1/8	94	51	41	GCMT040204-U	TS2	ТКУ06F
	4	TAFL1200F20	●	2	20	25	PT1/8	106	63	53	GCMT040204-U	TS2	ТКУ06F
12.5	2	TAFS1250F20	●	2	20	25	PT1/8	82	39	29	GCMT040204-U	TS2	ТКУ06F
	3	TAFM1250F20	●	2	20	25	PT1/8	94	51	41	GCMT040204-U	TS2	ТКУ06F
	4	TAFL1250F20	●	2	20	25	PT1/8	106	63	53	GCMT040204-U	TS2	ТКУ06F
13.0	2	TAFS1300F20	●	2	20	25	PT1/8	84	41	31	GCMT040204-U	TS2	ТКУ06F
	3	TAFM1300F20	●	2	20	25	PT1/8	97	54	44	GCMT040204-U	TS2	ТКУ06F
	4	TAFL1300F20	●	2	20	25	PT1/8	110	67	57	GCMT040204-U	TS2	ТКУ06F
13.5	2	TAFS1350F20	●	2	20	25	PT1/8	84	41	31	GCMT040204-U	TS2	ТКУ06F
	3	TAFM1350F20	●	2	20	25	PT1/8	97	54	44	GCMT040204-U	TS2	ТКУ06F
	4	TAFL1350F20	●	2	20	25	PT1/8	110	67	57	GCMT040204-U	TS2	ТКУ06F
14.0	2	TAFS1400F20	●	2	20	25	PT1/8	86	43	33	GCMT040204-U	TS2	ТКУ06F
	3	TAFM1400F20	●	2	20	25	PT1/8	100	57	47	GCMT040204-U	TS2	ТКУ06F
	4	TAFL1400F20	●	2	20	25	PT1/8	114	71	61	GCMT040204-U	TS2	ТКУ06F
14.5	2	TAFS1450F20	●	2	20	25	PT1/8	86	43	33	GCMT040204-U	TS2	ТКУ06F
	3	TAFM1450F20	●	2	20	25	PT1/8	100	57	47	GCMT040204-U	TS2	ТКУ06F
	4	TAFL1450F20	●	2	20	25	PT1/8	114	71	61	GCMT040204-U	TS2	ТКУ06F
15.0	2	TAFS1500F20	●	2	20	25	PT1/8	88	45	35	GPMT060204-U	TS2	ТКУ06F
	3	TAFM1500F20	●	2	20	25	PT1/8	103	60	50	GPMT060204-U	TS2	ТКУ06F
	4	TAFL1500F20	●	2	20	25	PT1/8	118	75	65	GPMT060204-U	TS2	ТКУ06F
15.5	2	TAFS1550F20	●	2	20	25	PT1/8	88	45	35	GPMT060204-U	TS2	ТКУ06F
	3	TAFM1550F20	●	2	20	25	PT1/8	103	60	50	GPMT060204-U	TS2	ТКУ06F
	4	TAFL1550F20	●	2	20	25	PT1/8	118	75	65	GPMT060204-U	TS2	ТКУ06F
16.0	2	TAFS1600F25	●	2	25	35	PT1/8	107	57	38	GPMT060204-U	TS2	ТКУ06F
	3	TAFM1600F25	●	2	25	35	PT1/8	123	73	54	GPMT060204-U	TS2	ТКУ06F
	4	TAFL1600F25	●	2	25	35	PT1/8	139	89	70	GPMT060204-U	TS2	ТКУ06F
16.5	2	TAFS1650F25	●	2	25	35	PT1/8	107	57	38	GPMT060204-U	TS2	ТКУ06F
	3	TAFM1650F25	●	2	25	35	PT1/8	123	73	54	GPMT060204-U	TS2	ТКУ06F

● : Есть на складе.

ОПИСАНИЕ ПЛАСТИН > L 145  
РЕЖИМЫ РЕЗАНИЯ > L 146  
РЕКОМЕНДАЦИИ > L 149  
ТЕХНИЧЕСКИЕ ДАННЫЕ > N001



L139

СВЕРЛЕНИЕ



# СВЕРЛЕНИЕ (СВЕРЛА СО СМЕННЫМИ ПЛАСТИНАМИ)

## TAFS, TAFM, TAFL

ТВЕРДЫЙ  
СПЛАВ

Диаметр сверла D1 (мм)	Глубина сверления (l/d)	Обозначение	Наличие	Число зубьев	Размеры (мм)						Обозначение пластины		
					D4	D7	D8	L1	L2	L3			
17.0	2	TAFS1700F25	●	2	25	35	PT1/8	109	59	41	GPMT060204-U	TS2	TKY06F
	3	TAFM1700F25	●	2	25	35	PT1/8	126	76	58	GPMT060204-U	TS2	TKY06F
	4	TAFL1700F25	●	2	25	35	PT1/8	143	93	75	GPMT060204-U	TS2	TKY06F
17.5	2	TAFS1750F25	●	2	25	35	PT1/8	109	59	41	GPMT060204-U	TS2	TKY06F
	3	TAFM1750F25	●	2	25	35	PT1/8	126	76	58	GPMT060204-U	TS2	TKY06F
	4	TAFL1750F25	●	2	25	35	PT1/8	143	93	75	GPMT060204-U	TS2	TKY06F
18.0	2	TAFS1800F25	●	2	25	35	PT1/8	111	61	43	GPMT070204-U	TS25	TKY08F
	3	TAFM1800F25	●	2	25	35	PT1/8	129	79	61	GPMT070204-U	TS25	TKY08F
	4	TAFL1800F25	●	2	25	35	PT1/8	147	97	79	GPMT070204-U	TS25	TKY08F
18.5	2	TAFS1850F25	●	2	25	35	PT1/8	111	61	43	GPMT070204-U	TS25	TKY08F
	3	TAFM1850F25	●	2	25	35	PT1/8	129	79	61	GPMT070204-U	TS25	TKY08F
19.0	2	TAFS1900F25	●	2	25	35	PT1/8	113	63	46	GPMT070204-U	TS25	TKY08F
	3	TAFM1900F25	●	2	25	35	PT1/8	132	82	65	GPMT070204-U	TS25	TKY08F
	4	TAFL1900F25	●	2	25	35	PT1/8	151	101	84	GPMT070204-U	TS25	TKY08F
19.5	2	TAFS1950F25	●	2	25	35	PT1/8	113	63	46	GPMT070204-U	TS25	TKY08F
	3	TAFM1950F25	●	2	25	35	PT1/8	132	82	65	GPMT070204-U	TS25	TKY08F
20.0	2	TAFS2000F25	●	2	25	35	PT1/8	115	65	48	GPMT070204-U	TS25	TKY08F
	3	TAFM2000F25	●	2	25	35	PT1/8	135	85	68	GPMT070204-U	TS25	TKY08F
	4	TAFL2000F25	●	2	25	35	PT1/8	155	105	88	GPMT070204-U	TS25	TKY08F
20.5	2	TAFS2050F25	●	2	25	35	PT1/8	115	65	48	GPMT070204-U	TS25	TKY08F
	3	TAFM2050F25	●	2	25	35	PT1/8	135	85	68	GPMT070204-U	TS25	TKY08F
21.0	2	TAFS2100F25	●	2	25	35	PT1/8	117	67	50	GPMT070204-U	TS25	TKY08F
	3	TAFM2100F25	●	2	25	35	PT1/8	138	88	71	GPMT070204-U	TS25	TKY08F
	4	TAFL2100F25	●	2	25	35	PT1/8	159	109	92	GPMT070204-U	TS25	TKY08F
21.5	2	TAFS2150F25	●	2	25	35	PT1/8	117	67	50	GPMT070204-U	TS25	TKY08F
	3	TAFM2150F25	●	2	25	35	PT1/8	138	88	71	GPMT070204-U	TS25	TKY08F
22.0	2	TAFS2200F25	●	2	25	35	PT1/8	119	69	53	GPMT070204-U	TS25	TKY08F
	3	TAFM2200F25	●	2	25	35	PT1/8	141	91	75	GPMT070204-U	TS25	TKY08F
	4	TAFL2200F25	●	2	25	35	PT1/8	163	113	97	GPMT070204-U	TS25	TKY08F
22.5	2	TAFS2250F25	●	2	25	35	PT1/8	119	69	53	GPMT070204-U	TS25	TKY08F
	3	TAFM2250F25	●	2	25	35	PT1/8	141	91	75	GPMT070204-U	TS25	TKY08F
23.0	2	TAFS2300F25	●	2	25	35	PT1/8	121	71	55	GPMT090304-U	TS3	TKY08F
	3	TAFM2300F25	●	2	25	35	PT1/8	144	94	78	GPMT090304-U	TS3	TKY08F
	4	TAFL2300F25	●	2	25	35	PT1/8	167	117	101	GPMT090304-U	TS3	TKY08F
23.5	2	TAFS2350F25	●	2	25	35	PT1/8	121	71	55	GPMT090304-U	TS3	TKY08F
	3	TAFM2350F25	●	2	25	35	PT1/8	144	94	78	GPMT090304-U	TS3	TKY08F
	4	TAFL2350F25	●	2	25	35	PT1/8	167	117	101	GPMT090304-U	TS3	TKY08F
24.0	2	TAFS2400F25	●	2	25	35	PT1/8	123	73	58	GPMT090304-U	TS3	TKY08F
	3	TAFM2400F25	●	2	25	35	PT1/8	147	97	82	GPMT090304-U	TS3	TKY08F
	4	TAFL2400F25	●	2	25	35	PT1/8	171	121	106	GPMT090304-U	TS3	TKY08F
24.5	2	TAFS2450F25	●	2	25	35	PT1/8	123	73	58	GPMT090304-U	TS3	TKY08F
	3	TAFM2450F25	●	2	25	35	PT1/8	147	97	82	GPMT090304-U	TS3	TKY08F
25.0	2	TAFS2500F32	●	2	32	42	PT1/8	130	75	60	GPMT090304-U	TS3	TKY08F
	3	TAFM2500F32	●	2	32	42	PT1/8	155	100	85	GPMT090304-U	TS3	TKY08F
	4	TAFL2500F25	●	2	25	35	PT1/8	180	125	110	GPMT090304-U	TS3	TKY08F
	4	TAFL2500F32	●	2	32	42	PT1/8	180	125	110	GPMT090304-U	TS3	TKY08F
25.5	2	TAFS2550F32	●	2	32	42	PT1/8	130	75	60	GPMT090304-U	TS3	TKY08F
	3	TAFM2550F32	●	2	32	42	PT1/8	155	100	85	GPMT090304-U	TS3	TKY08F

● : Есть на складе.



Диаметр сверла D1 (мм)	Глубина сверления (l/d)	Обозначение	Наличие	Число зубьев	Размеры (мм)						Обозначение пластины		
					D4	D7	D8	L1	L2	L3			
26.0	2	TAFS2600F32	●	2	32	42	PT1/8	132	77	62	GPMT090304-U	TS3	①ТКУ08F
	3	TAFM2600F32	●	2	32	42	PT1/8	158	103	88	GPMT090304-U	TS3	①ТКУ08F
	4	TAFL2600F32	●	2	32	42	PT1/8	184	129	114	GPMT090304-U	TS3	①ТКУ08F
26.5	2	TAFS2650F32	●	2	32	42	PT1/8	132	77	62	GPMT090304-U	TS3	①ТКУ08F
	3	TAFM2650F32	●	2	32	42	PT1/8	158	103	88	GPMT090304-U	TS3	①ТКУ08F
	4	TAFL2650F32	●	2	32	42	PT1/8	184	129	114	GPMT090304-U	TS3	①ТКУ08F
27.0	2	TAFS2700F32	●	2	32	42	PT1/8	134	79	65	GPMT090304-U	TS3	①ТКУ08F
	3	TAFM2700F32	●	2	32	42	PT1/8	161	106	92	GPMT090304-U	TS3	①ТКУ08F
	4	TAFL2700F32	●	2	32	42	PT1/8	188	133	119	GPMT090304-U	TS3	①ТКУ08F
27.5	2	TAFS2750F32	●	2	32	42	PT1/8	134	79	65	GPMT090304-U	TS3	①ТКУ08F
	3	TAFM2750F32	●	2	32	42	PT1/8	161	106	92	GPMT090304-U	TS3	①ТКУ08F
28.0	2	TAFS2800F32	●	2	32	42	PT1/8	136	81	67	GPMT11T308-U	TS4	②ТКУ15D
	3	TAFM2800F32	●	2	32	42	PT1/8	164	109	95	GPMT11T308-U	TS4	②ТКУ15D
	4	TAFL2800F32	●	2	32	42	PT1/8	192	137	123	GPMT11T308-U	TS4	②ТКУ15D
28.5	2	TAFS2850F32	●	2	32	42	PT1/8	136	81	67	GPMT11T308-U	TS4	②ТКУ15D
	3	TAFM2850F32	●	2	32	42	PT1/8	164	109	95	GPMT11T308-U	TS4	②ТКУ15D
	4	TAFL2850F40	●	2	40	50	PT1/8	202	137	123	GPMT11T308-U	TS4	②ТКУ15D
29.0	2	TAFS2900F32	●	2	32	42	PT1/8	138	83	70	GPMT11T308-U	TS4	②ТКУ15D
	3	TAFM2900F32	●	2	32	42	PT1/8	167	112	99	GPMT11T308-U	TS4	②ТКУ15D
	4	TAFL2900F32	●	2	32	42	PT1/8	196	141	128	GPMT11T308-U	TS4	②ТКУ15D
29.5	2	TAFS2950F32	●	2	32	42	PT1/8	138	83	70	GPMT11T308-U	TS4	②ТКУ15D
	3	TAFM2950F32	●	2	32	42	PT1/8	167	112	99	GPMT11T308-U	TS4	②ТКУ15D
30.0	2	TAFS3000F32	●	2	32	50	PT1/8	145	90	72	GPMT11T308-U	TS4	②ТКУ15D
	2	TAFS3000F40	●	2	40	50	PT1/4	155	90	72	GPMT11T308-U	TS4	②ТКУ15D
	3	TAFM3000F32	●	2	32	50	PT1/8	175	120	102	GPMT11T308-U	TS4	②ТКУ15D
	3	TAFM3000F40	●	2	40	50	PT1/4	185	120	102	GPMT11T308-U	TS4	②ТКУ15D
	4	TAFL3000F32	●	2	32	42	PT1/8	205	150	132	GPMT11T308-U	TS4	②ТКУ15D
	4	TAFL3000F40	●	2	40	50	PT1/4	215	150	132	GPMT11T308-U	TS4	②ТКУ15D
30.5	2	TAFS3050F40	●	2	40	50	PT1/4	155	90	72	GPMT11T308-U	TS4	②ТКУ15D
	3	TAFM3050F40	●	2	40	50	PT1/4	185	120	102	GPMT11T308-U	TS4	②ТКУ15D
31.0	2	TAFS3100F32	●	2	32	50	PT1/8	147	92	74	GPMT11T308-U	TS4	②ТКУ15D
	2	TAFS3100F40	●	2	40	50	PT1/4	157	92	74	GPMT11T308-U	TS4	②ТКУ15D
	3	TAFM3100F32	●	2	32	50	PT1/8	178	123	105	GPMT11T308-U	TS4	②ТКУ15D
	3	TAFM3100F40	●	2	40	50	PT1/4	188	123	105	GPMT11T308-U	TS4	②ТКУ15D
	4	TAFL3100F32	●	2	32	42	PT1/8	209	154	135	GPMT11T308-U	TS4	②ТКУ15D
	4	TAFL3100F40	●	2	40	50	PT1/4	219	154	136	GPMT11T308-U	TS4	②ТКУ15D
32.0	2	TAFS3200F32	●	2	32	50	PT1/8	149	94	77	GPMT11T308-U	TS4	②ТКУ15D
	2	TAFS3200F40	●	2	40	50	PT1/4	159	94	77	GPMT11T308-U	TS4	②ТКУ15D
	3	TAFM3200F32	●	2	32	50	PT1/8	181	126	109	GPMT11T308-U	TS4	②ТКУ15D
	3	TAFM3200F40	●	2	40	50	PT1/4	191	126	109	GPMT11T308-U	TS4	②ТКУ15D
	4	TAFL3200F32	●	2	32	42	PT1/8	213	158	141	GPMT11T308-U	TS4	②ТКУ15D
	4	TAFL3200F40	●	2	40	50	PT1/4	223	158	141	GPMT11T308-U	TS4	②ТКУ15D
33.0	2	TAFS3300F32	●	2	32	50	PT1/8	151	96	79	GPMT11T308-U	TS4	②ТКУ15D
	2	TAFS3300F40	●	2	40	50	PT1/4	161	96	79	GPMT11T308-U	TS4	②ТКУ15D
	3	TAFM3300F32	●	2	32	50	PT1/8	184	129	112	GPMT11T308-U	TS4	②ТКУ15D
	3	TAFM3300F40	●	2	40	50	PT1/4	194	129	112	GPMT11T308-U	TS4	②ТКУ15D
	4	TAFL3300F32	●	2	32	42	PT1/8	217	162	145	GPMT11T308-U	TS4	②ТКУ15D
	4	TAFL3300F40	●	2	40	50	PT1/4	227	162	145	GPMT11T308-U	TS4	②ТКУ15D

ОПИСАНИЕ ПЛАСТИН > L 145  
РЕЖИМЫ РЕЗАНИЯ > L 146  
РЕКОМЕНДАЦИИ > L 149  
ТЕХНИЧЕСКИЕ ДАННЫЕ > N001



# СВЕРЛЕНИЕ (СВЕРЛА СО СМЕННЫМИ ПЛАСТИНАМИ)

## TAFS, TAFM, TAFL

ТВЕРДЫЙ  
СПЛАВ

Диаметр сверла D1 (мм)	Глубина сверления (l/d)	Обозначение	Наличие	Число зубьев	Размеры (мм)						Обозначение пластины		
					D4	D7	D8	L1	L2	L3			
34.0	2	TAFS3400F32	●	2	32	50	PT1/8	153	98	82	GPMT11T308-U	TS4	TKY15D
	2	TAFS3400F40	●	2	40	50	PT1/4	163	98	82	GPMT11T308-U	TS4	TKY15D
	3	TAFM3400F32	●	2	32	50	PT1/8	187	132	116	GPMT11T308-U	TS4	TKY15D
	3	TAFM3400F40	●	2	40	50	PT1/4	197	132	116	GPMT11T308-U	TS4	TKY15D
	4	TAFL3400F32	●	2	32	42	PT1/8	231	166	150	GPMT11T308-U	TS4	TKY15D
	4	TAFL3400F40	●	2	40	50	PT1/4	231	166	150	GPMT11T308-U	TS4	TKY15D
35.0	2	TAFS3500F32	●	2	32	50	PT1/8	155	100	84	GPMT140408-U	TS55	TKY25D
	2	TAFS3500F40	●	2	40	50	PT1/4	165	100	84	GPMT140408-U	TS55	TKY25D
	3	TAFM3500F32	●	2	32	50	PT1/8	190	135	119	GPMT140408-U	TS55	TKY25D
	3	TAFM3500F40	●	2	40	50	PT1/4	200	135	119	GPMT140408-U	TS55	TKY25D
	4	TAFL3500F32	●	2	32	42	PT1/8	235	170	154	GPMT140408-U	TS5	TKY25D
	4	TAFL3500F40	●	2	40	50	PT1/4	235	170	154	GPMT140408-U	TS5	TKY25D
36.0	2	TAFS3600F32	●	2	32	50	PT1/8	157	102	86	GPMT140408-U	TS55	TKY25D
	2	TAFS3600F40	●	2	40	50	PT1/4	167	102	86	GPMT140408-U	TS55	TKY25D
	3	TAFM3600F32	●	2	32	50	PT1/8	193	138	122	GPMT140408-U	TS55	TKY25D
	3	TAFM3600F40	●	2	40	50	PT1/4	203	138	122	GPMT140408-U	TS55	TKY25D
	4	TAFL3600F32	●	2	32	42	PT1/8	229	174	158	GPMT140408-U	TS5	TKY25D
	4	TAFL3600F40	●	2	40	50	PT1/4	239	174	158	GPMT140408-U	TS5	TKY25D
37.0	2	TAFS3700F32	●	2	32	50	PT1/8	159	104	89	GPMT140408-U	TS55	TKY25D
	2	TAFS3700F40	●	2	40	50	PT1/4	169	104	89	GPMT140408-U	TS55	TKY25D
	3	TAFM3700F32	●	2	32	50	PT1/8	196	141	126	GPMT140408-U	TS55	TKY25D
	3	TAFM3700F40	●	2	40	50	PT1/4	206	141	126	GPMT140408-U	TS55	TKY25D
	4	TAFL3700F32	●	2	32	42	PT1/8	233	178	163	GPMT140408-U	TS5	TKY25D
	4	TAFL3700F40	●	2	40	50	PT1/4	243	178	163	GPMT140408-U	TS5	TKY25D
37.5	2	TAFS3750F32	●	2	32	50	PT1/8	159	104	89	GPMT140408-U	TS55	TKY25D
	2	TAFS3750F40	●	2	40	50	PT1/4	169	104	89	GPMT140408-U	TS55	TKY25D
	3	TAFM3750F32	●	2	32	50	PT1/8	196	141	126	GPMT140408-U	TS55	TKY25D
	3	TAFM3750F40	●	2	40	50	PT1/4	206	141	126	GPMT140408-U	TS55	TKY25D
	4	TAFL3750F32	●	2	32	42	PT1/8	233	178	163	GPMT140408-U	TS5	TKY25D
	4	TAFL3750F40	●	2	40	50	PT1/4	243	178	163	GPMT140408-U	TS5	TKY25D
38.0	2	TAFS3800F32	●	2	32	50	PT1/8	161	106	91	GPMT140408-U	TS55	TKY25D
	2	TAFS3800F40	●	2	40	50	PT1/4	171	106	91	GPMT140408-U	TS55	TKY25D
	3	TAFM3800F32	●	2	32	50	PT1/8	199	144	129	GPMT140408-U	TS55	TKY25D
	3	TAFM3800F40	●	2	40	50	PT1/4	209	144	129	GPMT140408-U	TS55	TKY25D
	4	TAFL3800F32	●	2	32	42	PT1/8	247	182	167	GPMT140408-U	TS5	TKY25D
	4	TAFL3800F40	●	2	40	50	PT1/4	247	182	167	GPMT140408-U	TS5	TKY25D
39.0	2	TAFS3900F32	●	2	32	50	PT1/8	163	108	94	GPMT140408-U	TS55	TKY25D
	2	TAFS3900F40	●	2	40	50	PT1/4	173	108	94	GPMT140408-U	TS55	TKY25D
	3	TAFM3900F32	●	2	32	50	PT1/8	202	147	133	GPMT140408-U	TS55	TKY25D
	3	TAFM3900F40	●	2	40	50	PT1/4	212	147	133	GPMT140408-U	TS55	TKY25D
	4	TAFL3900F32	●	2	32	42	PT1/8	251	186	172	GPMT140408-U	TS5	TKY25D
	4	TAFL3900F40	●	2	40	50	PT1/4	251	186	172	GPMT140408-U	TS5	TKY25D
40.0	2	TAFS4000F32	●	2	32	50	PT1/8	165	110	96	GPMT140408-U	TS55	TKY25D
	2	TAFS4000F40	●	2	40	50	PT1/4	175	110	96	GPMT140408-U	TS55	TKY25D
	3	TAFM4000F32	●	2	32	50	PT1/8	205	150	136	GPMT140408-U	TS55	TKY25D
	3	TAFM4000F40	●	2	40	50	PT1/4	215	150	136	GPMT140408-U	TS55	TKY25D
	4	TAFL4000F32	●	2	32	42	PT1/8	245	190	176	GPMT140408-U	TS5	TKY25D
	4	TAFL4000F40	●	2	40	50	PT1/4	255	190	176	GPMT140408-U	TS5	TKY25D

● : Есть на складе.

Диаметр сверла D1 (мм)	Глубина сверления (l/d)	Обозначение	Наличие	Число зубьев	Размеры (мм)						Обозначение пластины		
					D4	D7	D8	L1	L2	L3			
41.0	2	TAFS4100F40	●	2	40	50	PT1/4	177	112	98	GPMT140408-U	TS55	TKY25D
	3	TAFM4100F40	●	2	40	50	PT1/4	218	153	139	GPMT140408-U	TS55	TKY25D
	4	TAFL4100F40	●	2	40	50	PT1/4	259	194	180	GPMT140408-U	TS5	TKY25D
42.0	2	TAFS4200F40	●	2	40	50	PT1/4	179	114	101	GPMT140408-U	TS55	TKY25D
	3	TAFM4200F40	●	2	40	50	PT1/4	221	156	143	GPMT140408-U	TS55	TKY25D
	4	TAFL4200F40	●	2	40	50	PT1/4	263	198	185	GPMT140408-U	TS5	TKY25D
43.0	2	TAFS4300F40	●	2	40	50	PT1/4	181	116	103	GPMT140408-U	TS55	TKY25D
	3	TAFM4300F40	●	2	40	50	PT1/4	224	159	146	GPMT140408-U	TS55	TKY25D
	4	TAFL4300F40	●	2	40	50	PT1/4	267	202	189	GPMT140408-U	TS5	TKY25D
44.0	2	TAFS4400F40	●	2	40	50	PT1/4	183	118	106	GPMT140408-U	TS55	TKY25D
	3	TAFM4400F40	●	2	40	50	PT1/4	227	162	150	GPMT140408-U	TS55	TKY25D
	4	TAFL4400F40	●	2	40	50	PT1/4	271	206	194	GPMT140408-U	TS5	TKY25D
45.0	2	TAFS4500F40	●	2	40	54	PT1/4	185	120	108	GPMT140408-U	TS55	TKY25D
	3	TAFM4500F40	●	2	40	54	PT1/4	230	165	153	GPMT140408-U	TS55	TKY25D
	4	TAFL4500F40	●	2	40	54	PT1/4	275	210	198	GPMT140408-U	TS5	TKY25D
46.0	2	TAFS4600F40	●	2	40	54	PT1/4	187	122	110	GPMT140408-U	TS55	TKY25D
	3	TAFM4600F40	●	2	40	54	PT1/4	233	168	156	GPMT140408-U	TS55	TKY25D
	4	TAFL4600F40	●	2	40	54	PT1/4	279	214	202	GPMT140408-U	TS5	TKY25D
47.0	2	TAFS4700F40	●	2	40	54	PT1/4	189	124	113	GPMT140408-U	TS55	TKY25D
	3	TAFM4700F40	●	2	40	54	PT1/4	236	171	160	GPMT140408-U	TS55	TKY25D
	4	TAFL4700F40	●	2	40	54	PT1/4	283	218	207	GPMT140408-U	TS5	TKY25D
48.0	2	TAFS4800F40	●	2	40	54	PT1/4	191	126	115	GPMT140408-U	TS55	TKY25D
	3	TAFM4800F40	●	2	40	54	PT1/4	239	174	163	GPMT140408-U	TS55	TKY25D
	4	TAFL4800F40	●	2	40	54	PT1/4	287	222	211	GPMT140408-U	TS5	TKY25D
49.0	2	TAFS4900F40	●	4	40	58	PT1/4	198	133	118	GPMT090304-U	TS3	TKY08F
	3	TAFM4900F40	●	4	40	58	PT1/4	247	182	167	GPMT090304-U	TS3	TKY08F
	4	TAFL4900F40	●	4	40	58	PT1/4	296	231	216	GPMT090304-U	TS3	TKY08F
50.0	2	TAFS5000F40	●	4	40	58	PT1/4	200	135	120	GPMT090304-U	TS3	TKY08F
	3	TAFM5000F40	●	4	40	58	PT1/4	250	185	170	GPMT090304-U	TS3	TKY08F
	4	TAFL5000F40	●	4	40	58	PT1/4	300	235	220	GPMT090304-U	TS3	TKY08F
51.0	2	TAFS5100F40	●	4	40	58	PT1/4	202	137	122	GPMT090304-U	TS3	TKY08F
	3	TAFM5100F40	●	4	40	58	PT1/4	253	188	173	GPMT090304-U	TS3	TKY08F
	4	TAFL5100F40	●	4	40	58	PT1/4	304	239	224	GPMT090304-U	TS3	TKY08F
52.0	2	TAFS5200F40	●	4	40	58	PT1/4	204	139	125	GPMT090304-U	TS3	TKY08F
	3	TAFM5200F40	●	4	40	58	PT1/4	256	191	177	GPMT090304-U	TS3	TKY08F
	4	TAFL5200F40	●	4	40	58	PT1/4	308	243	229	GPMT090304-U	TS3	TKY08F
53.0	2	TAFS5300F40	●	4	40	63	PT1/4	206	141	127	GPMT090304-U	TS3	TKY08F
	3	TAFM5300F40	●	4	40	63	PT1/4	259	194	180	GPMT090304-U	TS3	TKY08F
	4	TAFL5300F40	●	4	40	63	PT1/4	312	247	233	GPMT090304-U	TS3	TKY08F
54.0	2	TAFS5400F40	●	4	40	63	PT1/4	208	143	128	GPMT090304-U	TS3	TKY08F
	3	TAFM5400F40	●	4	40	63	PT1/4	262	197	182	GPMT090304-U	TS3	TKY08F
	4	TAFL5400F40	●	4	40	63	PT1/4	316	251	236	GPMT090304-U	TS3	TKY08F
55.0	2	TAFS5500F40	●	4	40	63	PT1/4	210	145	130	GPMT090304-U	TS3	TKY08F
	3	TAFM5500F40	●	4	40	63	PT1/4	265	200	185	GPMT090304-U	TS3	TKY08F
	4	TAFL5500F40	●	4	40	63	PT1/4	320	255	240	GPMT090304-U	TS3	TKY08F
56.0	2	TAFS5600F40	●	4	40	63	PT1/4	212	147	132	GPMT090304-U	TS3	TKY08F
	3	TAFM5600F40	●	4	40	63	PT1/4	268	203	188	GPMT090304-U	TS3	TKY08F
	4	TAFL5600F40	●	4	40	63	PT1/4	324	259	244	GPMT090304-U	TS3	TKY08F

ОПИСАНИЕ ПЛАСТИН > L 145  
РЕЖИМЫ РЕЗАНИЯ > L 146  
РЕКОМЕНДАЦИИ > L 149  
ТЕХНИЧЕСКИЕ ДАННЫЕ > N001

# СВЕРЛЕНИЕ (СВЕРЛА СО СМЕННЫМИ ПЛАСТИНАМИ)

## TAFS, TAFM, TAFL

ТВЕРДЫЙ  
СПЛАВ

Углеродистая сталь Легированная сталь	Закалённая сталь	Нержавеющая сталь	Чугун	Лёгкий сплав	Жаропрочные сплавы
○		○	○		

● Более высокая жесткость.

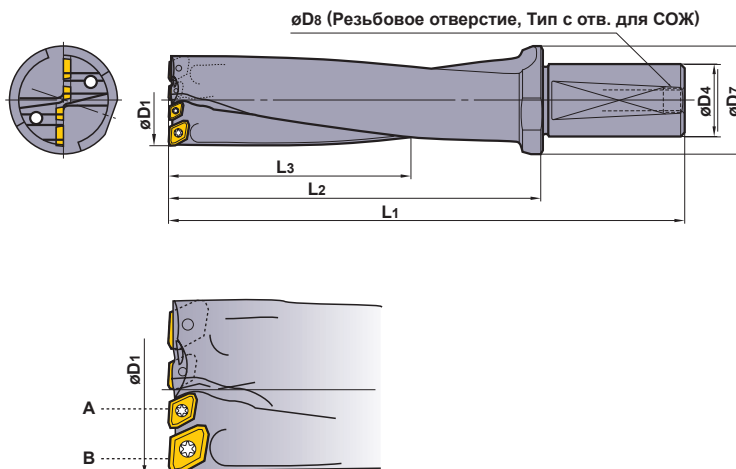

\* Резьбовое отверстие для винта в области фланца не предназначено для подачи СОЖ.

Диаметр сверла D1 (мм)	Глубина сверления (l/d)	Обозначение	Наличие	Число зубьев	Размеры (мм)						A	Обозначение пластины	Крепёжный винт	Ключ
					D4	D7	D8	L1	L2	L3				
50.0	2	TAFS5000F40-E	●	4	40	58	PT1/4	200	135	120	A	GPMT090304-U	TS3	①TKY08F
		GPMT11T308-U	TS4	②TKY15D										
	3	TAFM5000F40-E	●	4	40	58	PT1/4	250	185	170	A	GPMT090304-U	TS3	①TKY08F
		GPMT11T308-U	TS4	②TKY15D										
51.0	2	TAFS5100F40-E	●	4	40	58	PT1/4	202	137	122	A	GPMT090304-U	TS3	①TKY08F
		GPMT11T308-U	TS4	②TKY15D										
	3	TAFM5100F40-E	●	4	40	58	PT1/4	253	188	173	A	GPMT090304-U	TS3	①TKY08F
		GPMT11T308-U	TS4	②TKY15D										
52.0	2	TAFS5200F40-E	●	4	40	58	PT1/4	204	139	125	A	GPMT090304-U	TS3	①TKY08F
		GPMT11T308-U	TS4	②TKY15D										
	3	TAFM5200F40-E	●	4	40	58	PT1/4	256	191	177	A	GPMT090304-U	TS3	①TKY08F
		GPMT11T308-U	TS4	②TKY15D										
53.0	2	TAFS5300F40-E	●	4	40	63	PT1/4	206	141	127	A	GPMT11T308-U	TS4	②TKY15D
		GPMT11T308-U	TS4	②TKY15D										
	3	TAFM5300F40-E	●	4	40	63	PT1/4	259	194	180	A	GPMT11T308-U	TS4	②TKY15D
		GPMT11T308-U	TS4	②TKY15D										
54.0	2	TAFS5400F40-E	●	4	40	63	PT1/4	208	134	128	A	GPMT11T308-U	TS4	②TKY15D
		GPMT11T308-U	TS4	②TKY15D										
	3	TAFM5400F40-E	●	4	40	63	PT1/4	262	197	182	A	GPMT11T308-U	TS4	②TKY15D
		GPMT11T308-U	TS4	②TKY15D										
55.0	2	TAFS5500F40-E	●	4	40	63	PT1/4	210	145	130	A	GPMT11T308-U	TS4	②TKY15D
		GPMT11T308-U	TS4	②TKY15D										
	3	TAFM5500F40-E	●	4	40	63	PT1/4	265	200	185	A	GPMT11T308-U	TS4	②TKY15D
		GPMT11T308-U	TS4	②TKY15D										
56.0	2	TAFS5600F40-E	●	4	40	63	PT1/4	212	147	132	A	GPMT11T308-U	TS4	②TKY15D
		GPMT11T308-U	TS4	②TKY15D										
	3	TAFM5600F40-E	●	4	40	63	PT1/4	268	203	188	A	GPMT11T308-U	TS4	②TKY15D
		GPMT11T308-U	TS4	②TKY15D										
4	TAFL5600F40-E	●	4	40	63	PT1/4	324	259	244	A	GPMT11T308-U	TS4	②TKY15D	

● : Есть на складе.

## ПЛАСТИНЫ

Геометрия	Диам. сверла	Обозначение пластины	Размеры (мм)			Наличие				
			D1	S1	Re	VP15TF	UP20M	GP20M	UE6020	US735
<b>U1 Стружколом</b> 	ø12—ø14.5	<b>GCMT040204-U1</b>	5.0	2.38	0.4		●			
	ø15—ø17.5	<b>GPMT060204-U1</b>	5.56	2.38	0.4		●		●	
	ø18—ø22.5	<b>GPMT070204-U1</b>	6.35	2.38	0.4		●		●	
	ø23—ø27.5 ø49—ø56	<b>GPMT090304-U1</b>	7.94	3.18	0.4		●		●	
	ø28—ø34	<b>GPMT11T308-U1</b>	9.525	3.97	0.8		●		●	
	ø35—ø48	<b>GPMT140408-U1</b>	12.70	4.76	0.8		●		●	
<b>U2 Стружколом</b> 	ø12—ø14.5	<b>GCMT040204-U2</b>	5.0	2.38	0.4	●		●		
	ø15—ø17.5	<b>GPMT060204-U2</b>	5.56	2.38	0.4	●	●		●	●
	ø18—ø22.5	<b>GPMT070204-U2</b>	6.35	2.38	0.4	●	●		●	●
	ø23—ø27.5 ø49—ø56	<b>GPMT090304-U2</b>	7.94	3.18	0.4	●	●		●	●
	ø28—ø34	<b>GPMT11T308-U2</b>	9.525	3.97	0.8	●	●		●	●
	ø35—ø48	<b>GPMT140408-U2</b>	12.70	4.76	0.8	●	●		●	●
<b>U3 Стружколом</b> 	ø15—ø17.5	<b>GPMT060204-U3</b>	5.56	2.38	0.4		●		●	●
	ø18—ø22.5	<b>GPMT070204-U3</b>	6.35	2.38	0.4		●		●	●
	ø23—ø27.5 ø49—ø56	<b>GPMT090304-U3</b>	7.94	3.18	0.4		●		●	●
	ø28—ø34	<b>GPMT11T308-U3</b>	9.525	3.97	0.8		●		●	●
	ø35—ø48	<b>GPMT140408-U3</b>	12.70	4.76	0.8		●		●	●

## РЕКОМЕНДУЕМАЯ ПЛАСТИНА

### РЕКОМЕНДУЕМЫЙ СТРУЖКОЛОМ

◎ : 1-я рекомендация ○ : 2-я рекомендация

Обрабатываемый материал	P						M		K			
	Малоуглеродистые стали		Углеродистая сталь		Легированная сталь		Нержавеющая сталь		Чугун		Ковкий чугун	
	GCMT	GPMT	GCMT	GPMT	GCMT	GPMT	GCMT	GPMT	GCMT	GPMT	GCMT	GPMT
Стружколом												
<b>U1</b>	◎	◎	○	○	○	○	○	○	○	○	○	○
<b>U2</b>	○	○	◎	◎	◎	◎	◎	◎	◎	◎	◎	◎
<b>U3</b>		○		○		○		○		○		○

### РЕКОМЕНДУЕМОЕ ПОКРЫТИЕ ПЛАСТИН

◎ : 1-я рекомендация ○ : 2-я рекомендация

Обрабатываемый материал	P						M		K			
	Малоуглеродистые стали		Углеродистая сталь		Легированная сталь		Нержавеющая сталь		Чугун		Ковкий чугун	
	GCMT	GPMT	GCMT	GPMT	GCMT	GPMT	GCMT	GPMT	GCMT	GPMT	GCMT	GPMT
Стружколом												
<b>VP15TF</b>		○	◎	◎	◎	◎	◎	◎	◎	◎	◎	◎
<b>UP20M</b>	◎	◎	○	○	○	○	○	○	○	○	○	○
<b>GP20M</b>	○		○		○		○		○		○	
<b>UE6020</b>		○		○		○		○		○		○
<b>US735</b>		○		○		○		○		○		○

РЕЖИМЫ РЕЗАНИЯ > L146  
 РЕКОМЕНДАЦИИ > L149  
 ТЕХНИЧЕСКИЕ ДАННЫЕ > N001

## РЕКОМЕНДУЕМЫЕ РЕЖИМЫ РЕЗАНИЯ

Обрабатываемый материал	Твердость	Скорость резания (м/мин)			Стружколом	Подача (мм/об)					
		l/d=2, 3		l/d=4		Диаметр сверла (мм)					
		Ø12-Ø14.5	Ø15-			Ø12-Ø14.5	Ø15-Ø22.5	Ø23-Ø34	Ø35-Ø48	Ø49-Ø56	
Р	Малоуглеродистые стали	≤180НВ	150 (100-200)	200 (150-300)	140 (100-200)	U1	0.06 (0.04-0.10)	0.07 (0.04-0.10)	0.08 (0.04-0.10)	0.10 (0.04-0.12)	0.08 (0.04-0.10)
						U2	0.06 (0.04-0.10)	0.08 (0.04-0.12)	0.10 (0.04-0.12)	0.12 (0.04-0.14)	0.10 (0.04-0.12)
						U3	-	0.08 (0.04-0.12)	0.10 (0.04-0.12)	0.12 (0.04-0.14)	0.10 (0.04-0.12)
	Углеродистая сталь	180-280НВ	120 (80-160)	150 (120-180)	100 (80-120)	U1	0.06 (0.04-0.10)	0.09 (0.06-0.12)	0.12 (0.08-0.14)	0.15 (0.08-0.18)	0.12 (0.08-0.14)
						U2	0.06 (0.04-0.10)	0.12 (0.06-0.14)	0.14 (0.08-0.18)	0.17 (0.08-0.20)	0.14 (0.08-0.18)
						U3	-	0.12 (0.06-0.14)	0.14 (0.08-0.18)	0.17 (0.08-0.20)	0.14 (0.08-0.18)
Легированная сталь	180-280НВ	120 (80-160)	150 (120-180)	100 (80-120)	U1	0.06 (0.04-0.10)	0.08 (0.06-0.10)	0.09 (0.06-0.12)	0.11 (0.06-0.14)	0.09 (0.06-0.12)	
					U2	0.06 (0.04-0.10)	0.10 (0.06-0.12)	0.12 (0.08-0.16)	0.14 (0.08-0.18)	0.12 (0.08-0.16)	
					U3	-	0.10 (0.06-0.12)	0.12 (0.08-0.16)	0.14 (0.08-0.18)	0.12 (0.08-0.16)	
М	Нержавеющая сталь	≤200НВ	100 (80-120)	150 (120-200)	110 (80-140)	U1	0.07 (0.04-0.10)	0.07 (0.04-0.10)	0.08 (0.04-0.10)	0.10 (0.04-0.12)	0.08 (0.04-0.10)
						U2	0.07 (0.04-0.10)	0.08 (0.04-0.12)	0.10 (0.04-0.14)	0.12 (0.04-0.16)	0.10 (0.04-0.14)
						U3	-	0.08 (0.04-0.12)	0.10 (0.04-0.14)	0.12 (0.04-0.16)	0.10 (0.04-0.14)
К	Чугун	Предел прочности ≤350МПа	120 (80-160)	150 (120-180)	140 (110-160)	U1	0.07 (0.06-0.10)	0.07 (0.06-0.10)	0.10 (0.04-0.14)	0.10 (0.06-0.14)	0.10 (0.06-0.14)
						U2	0.07 (0.06-0.10)	0.15 (0.10-0.18)	0.20 (0.10-0.25)	0.20 (0.10-0.25)	0.20 (0.10-0.25)
						U3	-	0.15 (0.10-0.18)	0.20 (0.10-0.25)	0.20 (0.10-0.25)	0.20 (0.10-0.25)
	Ковкий чугун	Предел прочности ≤450МПа	120 (80-150)	150 (120-180)	100 (80-120)	U1	0.06 (0.04-0.10)	0.07 (0.06-0.10)	0.10 (0.06-0.14)	0.10 (0.06-0.14)	0.10 (0.06-0.14)
						U2	0.06 (0.04-0.10)	0.12 (0.08-0.14)	0.15 (0.08-0.20)	0.18 (0.08-0.20)	0.15 (0.08-0.20)
						U3	-	0.12 (0.08-0.14)	0.15 (0.08-0.20)	0.18 (0.08-0.20)	0.15 (0.08-0.20)

(Примечание) При использовании сверл с l/d=4 подача должна быть снижена до 80% от указанных выше.

### СОПРОТИВЛЕНИЕ РЕЗАНИЮ

Заготовка : DIN X5CrNi189 (220НВ) Скорость резания : 150м/мин Пластина : U2 Стружколом

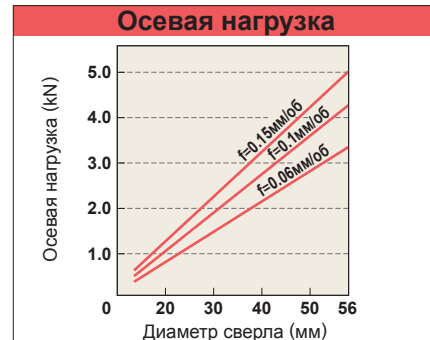
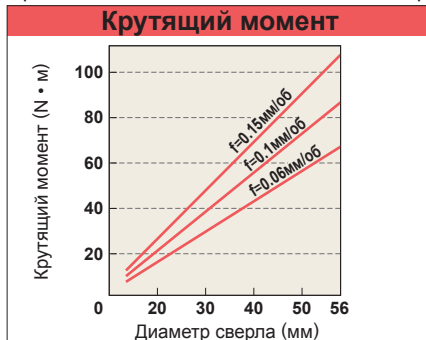
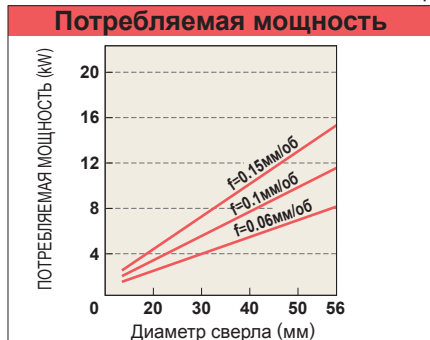

# ТОЧНАЯ ПЕРЕХОДНАЯ ВТУЛКА [JFS]

ТВЕРДЫЙ  
СПЛАВ

- Втулка спроектирована для универсальности применения сверл типа MVX и позволяет увеличивать диаметр сверления с припуском 0.1 мм.

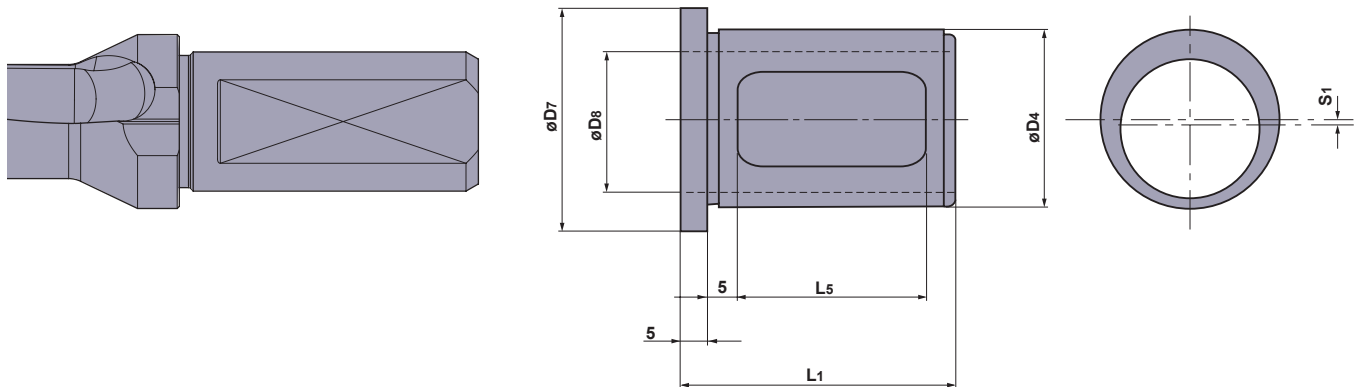

\* Увеличение: размер приращения диаметра обработки.

Обозначение комплекта	Обозначение втулки	Наличие	Размеры (мм)					*Увеличение (S1×2)	Подходящее сверло типа MVX, сверло типа TAF
			D7	D4	D8	L1	L5		
JFS-1	JFS2520-10	●	33	25	20	43	30	0.10	MVX1700 X $\odot$ F20 TAFS/M/L1200F20   TAFS/M/L1550F20
	2520-20	●	33	25	20	43	30	0.20	
	2520-30	●	33	25	20	43	30	0.30	
	2520-40	●	33	25	20	43	30	0.40	
	2520-50	●	33	25	20	43	30	0.50	
JFS-2	JFS3225-10	●	40	32	25	50	34	0.10	MVX1750 X $\odot$ F25   MVX2550 X $\odot$ F25 TAFS/M/L1600F25   TAFS/M/L2450F25
	3225-20	●	40	32	25	50	34	0.20	
	3225-30	●	40	32	25	50	34	0.30	
	3225-40	●	40	32	25	50	34	0.40	
	3225-50	●	40	32	25	50	34	0.50	
JFS-3	JFS4032-10	●	48	40	32	55	40	0.10	TMVX2600 X $\odot$ F32   MVX3000 X $\odot$ F32 TAFS/M/L2500F32   TAFS/M/L2950F32
	4032-20	●	48	40	32	55	40	0.20	
	4032-30	●	48	40	32	55	40	0.30	
	4032-40	●	48	40	32	55	40	0.40	
	4032-50	●	48	40	32	55	40	0.50	

\* Не подходит для хвостовиков диаметром 40мм.

## УКАЗАНИЯ ПО ВЫБОРУ ТОЧНОЙ ПЕРЕХОДНОЙ ВТУЛКИ

Требуемый диаметр = ( $\phi$  сверла + увеличение JFS) + 0.1 мм

Пример: Требуемый диаметр равен 20.3 мм (припуск принимается как 0.1 мм)

$$\phi 20.3 = (\text{MVX2000 X } \odot \text{F25} + \text{JFS3225-20}) + 0.1$$

↓  
сверло  $\phi 20$  мм      ↓  
Использовано увеличение JFS равное 0.2 мм      ↓  
Припуск

<Выбранный инструмент>  
Сверла : MVX2000 X  $\odot$ F25  
ТОЧНАЯ ПЕРЕХОДНАЯ ВТУЛКА [JFS]  
: JFS3225-20

(Примечание) Припуск может быть различным в зависимости от используемых режимов резания. Пожалуйста, используйте приведенную выше информацию как справочную.

## ЗАКАЗ ТОЧНОЙ ПЕРЕХОДНОЙ ВТУЛКИ

### ●1-й метод приобретения.

Припуск может быть различным в зависимости от используемых режимов резания. Поэтому рекомендуется заказывать комплект втулок. При размещении заказа, пожалуйста, укажите обозначение комплекта (5 втулок в комплекте).

### ●2-й метод приобретения.

Возможен заказ одной или нескольких втулок. При размещении заказа, пожалуйста, укажите обозначение втулки.

● : Есть на складе.

# ТОЧНАЯ ПЕРЕХОДНАЯ ВТУЛКА [JFS]

ТВЕРДЫЙ  
СПЛАВ

## ■ ПРИМЕНЕНИЕ ТОЧНОЙ ПЕРЕХОДНОЙ ВТУЛКИ

1 При установке сверла в оправку, проследите чтобы V-образная канавка на внешней боковой кромке фланца сверла совпала с круглым отверстием на внешней боковой кромке втулки и с винтами на боковой стороне державки. (Если сверло не имеет V-образной канавки, выровняйте лыску на хвостовике сверла и круглые отверстия на втулке.)

2 Для крепления сверла вставьте винт А державки для боковой фиксации непосредственно через открытую зону муфты. Затяните винт В настолько, насколько это возможно без повреждения муфты.

(Примечание)

- Хорошая настройка не может быть выполнена диаметром втулки.
- Не может использоваться со сборными зажимными оправками.

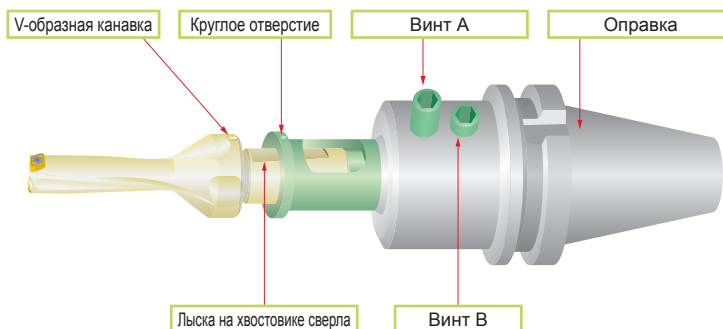

## ■ ПРИМЕНЕНИЕ СВЕРЛА ТИПА MVX

### ● Использование на токарном станке

(1) Внешняя пластина и ось X станка должны располагаться параллельно. Сверло разработано таким образом, чтобы центр внутренней пластины находился на 0-0,15мм ниже при совмещении центра сверла и центра шпинделя станка.

\* Может произойти поломка внутренней пластины, если высота центра внутренней пластины будет превышать высоту оси X станка.

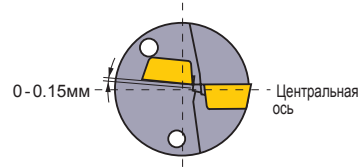

(2) Чтобы отрегулировать диаметр отверстия при помощи смещения сверла, сместите сверло в положительном направлении по оси X (увеличивая диаметр отверстия). См. список с размерами держателя для получения информации о максимальном диапазоне регулировки каждого держателя.

\* Не рекомендуется выполнять регулировку в отрицательном направлении по оси X (уменьшая диаметр отверстия), т.к. это может привести к наложению отверстия и держателя.

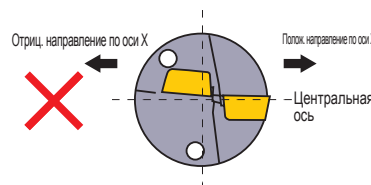

(3) При сверлении сквозных отверстий на токарном станке диск может выпадать из высверленного отверстия обрабатываемой детали с высокой скоростью. Настоятельно рекомендуется использовать защитную экипировку во избежание травм и повреждения оборудования.

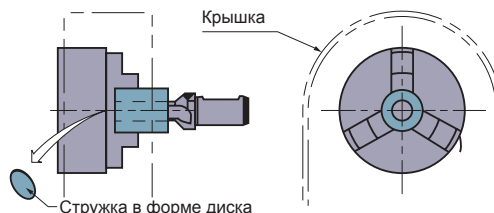

СВЕРЛЕНИЕ

## ПРИМЕНЕНИЕ СВЕРЛА ТИПА TAF

- Перед обработкой убедитесь, что жесткость станка и зажима инструмента максимальна.
- Используйте следующую схему для определения давления и количества СОЖ. Охлаждение является очень важным фактором в эффективности обработки данными сверлами.
- Не используйте для сверления пакета заготовок. Как и большинство сверл оснащенных сменными пластинами, при выходе сверла из заготовки данные сверла производят стружку округлой дисковой формы, которая может повредить поверхность заготовок и сверла.

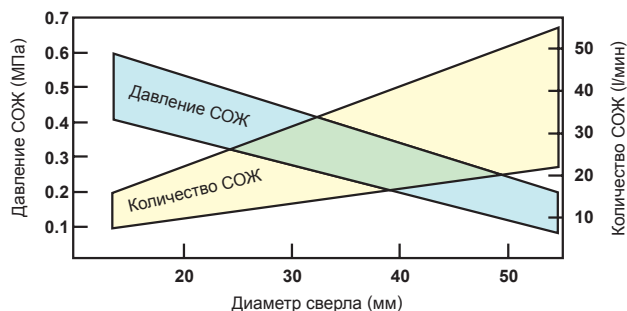

### Использование на токарном станке

- (1) Внутренняя режущая кромка должна находиться на расстоянии 0 - 0.2 мм от центра.
- (2) Для настройки диаметра отверстия при установке сверла внешняя режущая кромка и ось станка должны быть параллельны.
- (3) При изготовлении отверстий больших диаметров. Смещение сверла должно быть больше 2% от диаметра сверла. Это невозможно при изготовлении отверстия с диаметром меньше номинального диаметра сверла.
- (4) При сверлении сквозного отверстия на токарном станке, получаемая стружка дисковой формы может отлетать с очень большой скоростью. Для обеспечения безопасности рекомендуется применять защитный кожух.

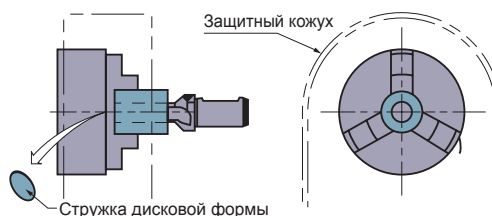
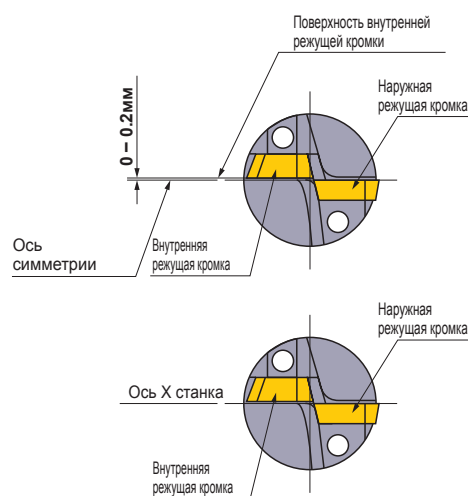

# СВЕРЛЕНИЕ (СВЕРЛА С НАПАЙНЫМИ ПЛАСТИНАМИ)

## BRS

- Превосходные точность обработки и вывод стружки благодаря пластинам с большим передним углом.
- Высокоэффективны, высокоточная обработка.
- Применяются для сверления нержавеющих сталей, малоуглеродистых сталей и обычных сталей. (l/d=3)

ТВЕРДЫЙ  
СПЛАВ

Углеродистая сталь Легированная сталь	Закалённая сталь	Нержавеющая сталь	Чугун	Лёгкий сплав	Жаропрочные сплавы
◎		◎	○		

	$14 \leq D_1 \leq 18$	$18 < D_1 \leq 30$
	$\begin{matrix} 0 \\ -0.018 \end{matrix}$	$\begin{matrix} 0 \\ -0.021 \end{matrix}$

(l/d=3)

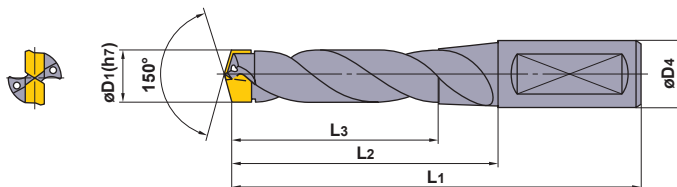

Диам. сверла D1 (мм)	Стандартный диаметр		Промежуточный диаметр		Размеры (мм)				
	Обозначение	Наличие UP20M	Диапазон диаметров сверл (D1)	Обозначение	L3	L2	L1	D4	
14.0	<b>BRS1400S16</b>	●	14.0 < D1 < 14.5	<b>BRS□□□□S16</b>	52	66	114	16	
14.5	<b>1450S16</b>	●			52	66	114	16	
15.0	<b>1500S20</b>	★	14.5 < D1 < 15.5	<b>BRS□□□□S20</b>	61	76	126	20	
15.5	<b>1550S20</b>	●			61	76	126	20	
16.0	<b>1600S20</b>	●	15.5 < D1 < 16.5		65	81	131	20	
16.5	<b>1650S20</b>	●			65	81	131	20	
17.0	<b>1700S20</b>	●	16.5 < D1 < 17.5		69	86	136	20	
17.5	<b>1750S20</b>	●			69	86	136	20	
18.0	<b>1800S20</b>	●	17.5 < D1 < 18.5		73	91	141	20	
18.5	<b>1850S20</b>	●			73	91	141	20	
19.0	<b>1900S25</b>	●	18.5 < D1 < 19.5		<b>BRS□□□□S25</b>	77	101	157	25
19.5	<b>1950S25</b>	●				77	101	157	25
20.0	<b>2000S25</b>	●	19.5 < D1 < 20.5	81		101	157	25	
20.5	<b>2050S25</b>	●		81		101	157	25	
21.0	<b>2100S25</b>	●	20.5 < D1 < 21.5	80		101	157	25	
21.5	<b>2150S25</b>	★		80		101	157	25	
22.0	<b>2200S25</b>	●	21.5 < D1 < 22.5	84		106	162	25	
22.5	<b>2250S25</b>	★		84		106	162	25	
23.0	<b>2300S25</b>	●	22.5 < D1 < 23.5	83		106	162	25	
23.5	<b>2350S25</b>	★		83		106	162	25	
24.0	<b>2400S32</b>	●	23.5 < D1 < 24.5	<b>BRS□□□□S32</b>	87	111	171	32	
24.5	<b>2450S32</b>	●			87	111	171	32	
25.0	<b>2500S32</b>	●	24.5 < D1 < 25.5		86	111	171	32	
25.5	<b>2550S32</b>	★			86	111	171	32	
26.0	<b>2600S32</b>	★	25.5 < D1 < 26.5		90	116	176	32	
26.5	<b>2650S32</b>	●			90	116	176	32	
27.0	<b>2700S32</b>	★	26.5 < D1 < 27.5		89	116	176	32	
27.5	<b>2750S32</b>	★			89	116	176	32	
28.0	<b>2800S32</b>	●	27.5 < D1 < 28.5		93	121	181	32	
28.5	<b>2850S32</b>	★			93	121	181	32	
29.0	<b>2900S32</b>	★	28.5 < D1 < 29.5	97	126	186	32		
29.5	<b>2950S32</b>	★		97	126	186	32		
30.0	<b>3000S32</b>	★	29.5 < D1 < 30.5	96	126	186	32		

Для заказа промежуточных диаметров, пожалуйста, впишите диаметр 4-мя цифрами в поля □□□□ условного обозначения.  
(Например : UP20M BRS□2□5□3□0S32 для диаметра φ25.30 мм)

● : Есть на складе. ★ : Со склада в Японии.

L150

СВЕРЛЕНИЕ

## РЕКОМЕНДУЕМЫЕ РЕЖИМЫ РЕЗАНИЯ

Обрабатываемый материал	Твердость	Диам. сверла $\phi 14.0 - \phi 20.0$		Диам. сверла $\phi 20.0 - \phi 30.0$	
		Скорость резания (м/мин)	Подача (мм/об)	Скорость резания (м/мин)	Подача (мм/об)
<b>P</b> Малоуглеродистые стали	$\leq 180\text{HV}$	65 (50–75)	0.30 (0.20–0.40)	70 (55–85)	0.35 (0.20–0.45)
	Предел прочности 400–500МПа	80 (70–90)	0.30 (0.25–0.35)	80 (70–90)	0.35 (0.30–0.45)
		Предел прочности 490–610МПа	70 (60–80)	0.25 (0.20–0.30)	70 (60–80)
	Предел прочности 570–720МПа	60 (50–70)	0.25 (0.20–0.30)	60 (50–70)	0.30 (0.20–0.35)
Углеродистая сталь Легированная сталь	180–280HV	60 (45–70)	0.25 (0.10–0.35)	65 (45–80)	0.30 (0.15–0.35)
	280–350HV	55 (40–65)	0.20 (0.15–0.35)	60 (45–70)	0.25 (0.15–0.35)
<b>M</b> Нержавеющая сталь (Аустенитная)	$\leq 200\text{HV}$	70 (50–90)	0.30 (0.20–0.40)	80 (60–100)	0.30 (0.20–0.40)
<b>K</b> Чугун	Предел прочности $\leq 350\text{МПа}$	75 (60–110)	0.30 (0.20–0.40)	80 (60–100)	0.35 (0.25–0.50)
	Предел прочности $\leq 450\text{МПа}$	75 (60–100)	0.30 (0.20–0.40)	80 (60–100)	0.35 (0.20–0.45)
Ковкий чугун	Предел прочности $\leq 450\text{МПа}$	75 (60–100)	0.30 (0.20–0.40)	80 (60–100)	0.35 (0.20–0.45)
	Предел прочности 500–800МПа	70 (55–90)	0.25 (0.15–0.35)	75 (55–90)	0.30 (0.15–0.40)

(Примечание) Используйте приведенные в таблице режимы резания как первоначальные. Режимы резания корректируются в зависимости от мощности и жесткости станка и формы заготовки.

## СОПРОТИВЛЕНИЕ РЕЗАНИЮ

Заготовка : DIN X5CrNi189 Глубина сверления :  $l/d=3$  (Сквозное отверстие) Скорость резания : 70м/мин WSO (10%)

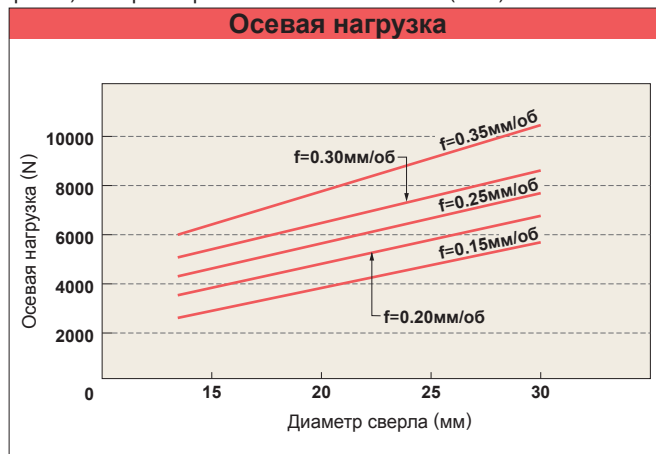
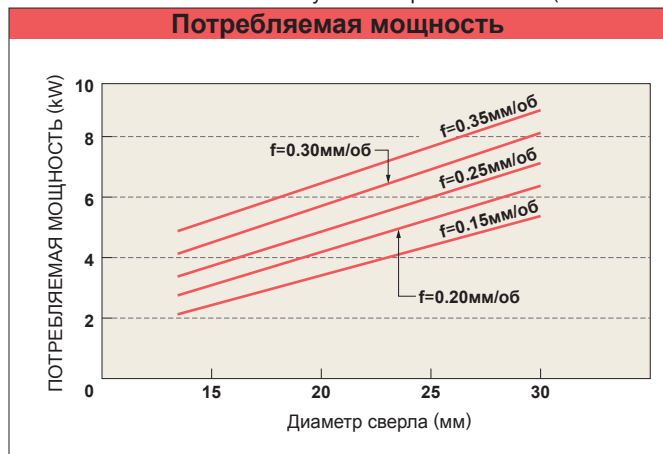

# СВЕРЛЕНИЕ (СВЕРЛА С НАПАЙНЫМИ ПЛАСТИНАМИ)

## BRM

- Превосходные точность обработки и вывод стружки благодаря пластинам с большим передним углом.
- Высокоэффективны, высоточная обработка.
- Применяются для сверления нержавеющих сталей, малоуглеродистых сталей и обычных сталей. (l/d=5)

ТВЕРДЫЙ СПЛАВ

Углеродистая сталь Легированная сталь	Закалённая сталь	Нержавеющая сталь	Чугун	Лёгкий сплав	Жаропрочные сплавы
◎		◎	○		

	14 ≤ D1 ≤ 18	18 < D1 ≤ 30
	0 -0.027	0 -0.033

(l/d=5)

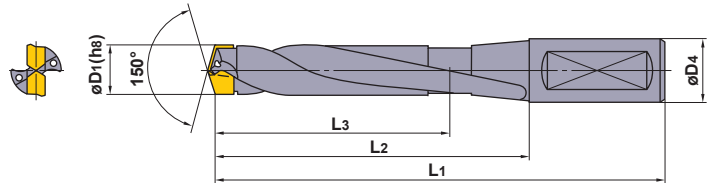

Диам. сверла D1 (мм)	Стандартный диаметр		Промежуточный диаметр		Размеры (мм)				
	Обозначение	Наличие UP20M	Диапазон диаметров сверл (D1)	Обозначение	L3	L2	L1	D4	
14.0	<b>BRM1400S16</b>	●	14.0 < D1 < 14.5	<b>BRM□□□□S16</b>	78	92	140	16	
14.5	<b>1450S16</b>	★			78	92	140	16	
15.0	<b>1500S20</b>	★	14.5 < D1 < 15.5	<b>BRM□□□□S20</b>	85	100	150	20	
15.5	<b>1550S20</b>	★			85	100	150	20	
16.0	<b>1600S20</b>	●	15.5 < D1 < 16.5		89	105	155	20	
16.5	<b>1650S20</b>	★			89	105	155	20	
17.0	<b>1700S20</b>	●	16.5 < D1 < 17.5		98	115	165	20	
17.5	<b>1750S20</b>	●			98	115	165	20	
18.0	<b>1800S20</b>	●	17.5 < D1 < 18.5		102	120	170	20	
18.5	<b>1850S20</b>	●			102	120	170	20	
19.0	<b>1900S25</b>	★	18.5 < D1 < 19.5		<b>BRM□□□□S25</b>	105	124	180	25
19.5	<b>1950S25</b>	★				105	124	180	25
20.0	<b>2000S25</b>	★	19.5 < D1 < 20.5	114		134	190	25	
20.5	<b>2050S25</b>	●		114		134	190	25	
21.0	<b>2100S25</b>	●	20.5 < D1 < 21.5	118		139	195	25	
21.5	<b>2150S25</b>	★		118		139	195	25	
22.0	<b>2200S25</b>	●	21.5 < D1 < 22.5	122		144	200	25	
22.5	<b>2250S25</b>	●		122		144	200	25	
23.0	<b>2300S25</b>	●	22.5 < D1 < 23.5	126		149	205	25	
23.5	<b>2350S25</b>	★		126		149	205	25	
24.0	<b>2400S32</b>	●	23.5 < D1 < 24.5	<b>BRM□□□□S32</b>	136	160	220	32	
24.5	<b>2450S32</b>	●			136	160	220	32	
25.0	<b>2500S32</b>	●	24.5 < D1 < 25.5		140	165	225	32	
25.5	<b>2550S32</b>	★			140	165	225	32	
26.0	<b>2600S32</b>	●	25.5 < D1 < 26.5		144	170	230	32	
26.5	<b>2650S32</b>	●			144	170	230	32	
27.0	<b>2700S32</b>	★	26.5 < D1 < 27.5		148	175	235	32	
27.5	<b>2750S32</b>	★			148	175	235	32	
28.0	<b>2800S32</b>	★	27.5 < D1 < 28.5		157	185	245	32	
28.5	<b>2850S32</b>	★			157	185	245	32	
29.0	<b>2900S32</b>	★	28.5 < D1 < 29.5	161	190	250	32		
29.5	<b>2950S32</b>	★		161	190	250	32		
30.0	<b>3000S32</b>	★	29.5 < D1 < 30.0	165	195	255	32		

Для заказа промежуточных диаметров, пожалуйста, впишите диаметр 4-мя цифрами в поля □□□□ условного обозначения.  
(Например : UP20M BRM[2][5][3][0]S32 для диаметра φ25.30 мм)

● : Есть на складе. ★ : Со склада в Японии.

## РЕКОМЕНДУЕМЫЕ РЕЖИМЫ РЕЗАНИЯ

Обрабатываемый материал	Твердость	Диам. сверла $\phi 14.0 - \phi 20.0$		Диам. сверла $\phi 20.0 - \phi 30.0$	
		Скорость резания (м/мин)	Подача (мм/об)	Скорость резания (м/мин)	Подача (мм/об)
<b>P</b> Малоуглеродистые стали	$\leq 180\text{HB}$	65 (50–75)	0.30 (0.20–0.40)	70 (55–85)	0.35 (0.20–0.45)
	Предел прочности 400–500МПа	70 (60–80)	0.30 (0.25–0.35)	70 (60–80)	0.35 (0.30–0.45)
		Предел прочности 490–610МПа	60 (50–70)	0.25 (0.20–0.30)	60 (50–70)
	Предел прочности 570–720МПа	50 (40–60)	0.25 (0.20–0.30)	50 (40–60)	0.30 (0.20–0.35)
Углеродистая сталь Легированная сталь	180–280HB	60 (45–70)	0.25 (0.15–0.35)	65 (45–80)	0.30 (0.15–0.40)
	280–350HB	55 (40–65)	0.20 (0.15–0.35)	60 (45–70)	0.25 (0.15–0.35)
<b>M</b> Нержавеющая сталь (Аустенитная)	$\leq 200\text{HB}$	60 (50–80)	0.25 (0.15–0.35)	65 (50–80)	0.30 (0.20–0.40)
<b>K</b> Чугун	Предел прочности $\leq 350\text{МПа}$	65 (50–100)	0.30 (0.20–0.40)	70 (50–100)	0.35 (0.25–0.50)
		65 (50–90)	0.30 (0.20–0.40)	70 (50–90)	0.35 (0.20–0.45)
	Предел прочности 500–800МПа	60 (45–80)	0.25 (0.15–0.35)	65 (45–80)	0.30 (0.15–0.40)

(Примечание) Используйте приведенные в таблице режимы резания как первоначальные. Режимы резания корректируются в зависимости от мощности и жесткости станка и формы заготовки.

## СОПРОТИВЛЕНИЕ РЕЗАНИЮ

Заготовка : DIN X5CrNi189 Глубина сверления :  $l/d=5$  (Сквозное отверстие) Скорость резания : 60м/мин WSO (10%)

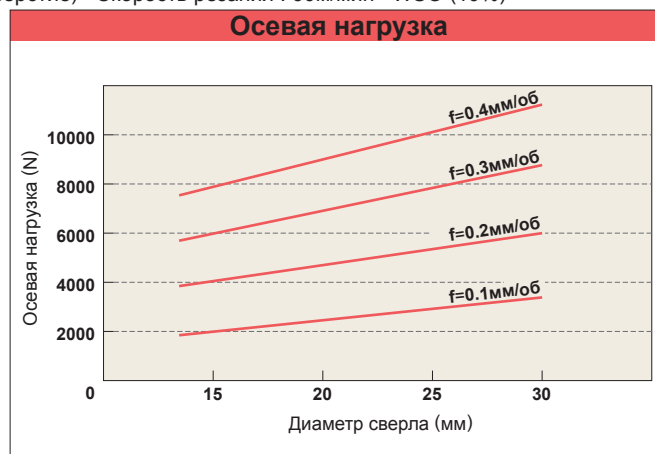
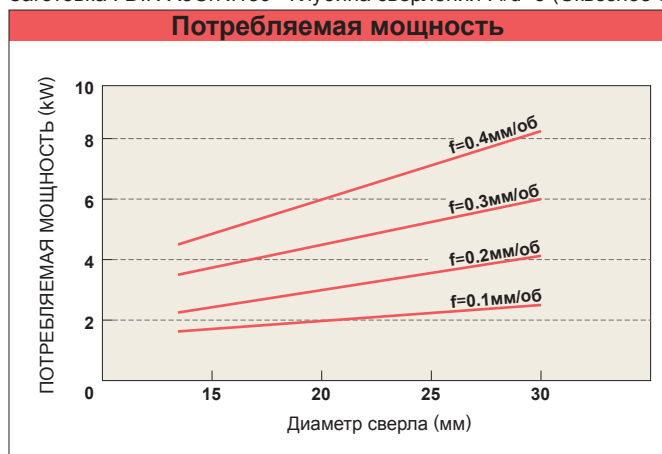

# СВЕРЛЕНИЕ (СВЕРЛА С НАПАЙНЫМИ ПЛАСТИНАМИ)

## BRA

- Низкая осевая нагрузка благодаря заниженной ленточке.
- Легко перетачиваемое.

ТВЕРДЫЙ СПЛАВ

Углеродистая сталь Легированная сталь	Закалённая сталь	Нержавеющая сталь	Чугун	Лёгкий сплав	Жаропрочные сплавы	8 ≤ D1 ≤ 10	10 < D1 ≤ 18	18 < D1 ≤ 30	30 < D1 ≤ 40
◎		○	○			$\begin{matrix} 0 \\ -0.015 \end{matrix}$	$\begin{matrix} 0 \\ -0.018 \end{matrix}$	$\begin{matrix} 0 \\ -0.021 \end{matrix}$	$\begin{matrix} 0 \\ -0.025 \end{matrix}$

● **Общего применения** (Углеродистая сталь, Легированная сталь, Нержавеющая сталь)

(l/d=3)

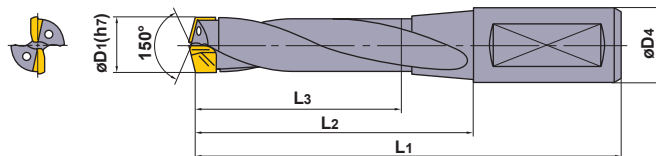

Диам. сверла D1 (мм)	Стандартный диаметр		Промежуточный диаметр		Размеры (мм)			
	Обозначение	Наличие UP20M	Диапазон диаметров сверл (D1)	Обозначение	L3	L2	L1	D4
8.0	<b>BRA0800S16</b>	★	8.0 < D1 < 8.5	<b>BRA□□□□S16</b>	23	35	83	16
8.5	<b>0850S16</b>	★			23	35	83	16
9.0	<b>0900S16</b>	★	8.5 < D1 < 9.5		28	40	88	16
9.5	<b>0950S16</b>	★			28	40	88	16
10.0	<b>1000S16</b>	★	9.5 < D1 < 10.5		35	45	93	16
10.5	<b>1050S16</b>	★			35	45	93	16
11.0	<b>1100S16</b>	★	10.5 < D1 < 11.5		40	51	99	16
11.5	<b>1150S16</b>	★			40	51	99	16
12.0	<b>1200S16</b>	★	11.5 < D1 < 12.5		44	56	104	16
12.5	<b>1250S16</b>	★			44	56	104	16
13.0	<b>1300S16</b>	★	12.5 < D1 < 13.5		48	61	109	16
13.5	<b>1350S16</b>	★			48	61	109	16
14.0	<b>1400S16</b>	★	13.5 < D1 < 14.5		52	66	114	16
14.5	<b>1450S16</b>	★			52	66	114	16
15.0	<b>1500S20</b>	★	14.5 < D1 < 15.5		61	76	126	20
15.5	<b>1550S20</b>	★			61	76	126	20
16.0	<b>1600S20</b>	★	15.5 < D1 < 16.5	65	81	131	20	
16.5	<b>1650S20</b>	★		65	81	131	20	
17.0	<b>1700S20</b>	★	16.5 < D1 < 17.5	69	86	136	20	
17.5	<b>1750S20</b>	★		69	86	136	20	
18.0	<b>1800S20</b>	★	17.5 < D1 < 18.5	73	91	141	20	
18.5	<b>1850S20</b>	★		73	91	141	20	
19.0	<b>1900S25</b>	★	18.5 < D1 < 19.5	77	101	157	25	
19.5	<b>1950S25</b>	★		77	101	157	25	
20.0	<b>2000S25</b>	★	19.5 < D1 < 20.5	81	101	157	25	
20.5	<b>2050S25</b>	★		81	101	157	25	
21.0	<b>2100S25</b>	★	20.5 < D1 < 21.5	80	101	157	25	
21.5	<b>2150S25</b>	★		80	101	157	25	
22.0	<b>2200S25</b>	★	21.5 < D1 < 22.5	84	106	162	25	
22.5	<b>2250S25</b>	★		84	106	162	25	

★ : Со склада в Японии. □ : Нет на складе, выпускается исключительно под заказ.

Диам. сверла D1 (мм)	Стандартный диаметр		Промежуточный диаметр		Размеры (мм)				
	Обозначение	Наличие UP20M	Диапазон диаметров сверл (D1)	Обозначение	L3	L2	L1	D4	
23.0	<b>BRA2300S25</b>	★	22.5<D1<23.5	<b>BRA□□□□S25</b>	83	106	162	25	
23.5	<b>2350S25</b>	★			83	106	162	25	
24.0	<b>2400S32</b>	★	23.5<D1<24.5	<b>BRA□□□□S32</b>	87	111	171	32	
24.5	<b>2450S32</b>	★			87	111	171	32	
25.0	<b>2500S32</b>	★	24.5<D1<25.5		86	111	171	32	
25.5	<b>2550S32</b>	★			86	111	171	32	
26.0	<b>2600S32</b>	★	25.5<D1<26.5		90	116	176	32	
26.5	<b>2650S32</b>	★			90	116	176	32	
27.0	<b>2700S32</b>	★	26.5<D1<27.5		89	116	176	32	
27.5	<b>2750S32</b>	★			89	116	176	32	
28.0	<b>2800S32</b>	★	27.5<D1<28.5		93	121	181	32	
28.5	<b>2850S32</b>	★			93	121	181	32	
29.0	<b>2900S32</b>	★	28.5<D1<29.5		97	126	186	32	
29.5	<b>2950S32</b>	★			97	126	186	32	
30.0	<b>3000S32</b>	★	29.5<D1<30.5		96	126	186	32	
30.5	<b>3050S32</b>	★			96	126	186	32	
31.0	<b>3100S40</b>	□	30.5<D1<31.5		<b>BRA□□□□S40</b>	96	127	197	40
31.5	<b>3150S40</b>	□				96	127	197	40
32.0	<b>3200S40</b>	□	31.5<D1<32.5			100	132	202	40
32.5	<b>3250S40</b>	□				100	132	202	40
33.0	<b>3300S40</b>	□	32.5<D1<33.5			104	137	207	40
33.5	<b>3350S40</b>	□				104	137	207	40
34.0	<b>3400S40</b>	□	33.5<D1<34.5	103		137	207	40	
34.5	<b>3450S40</b>	□		103		137	207	40	
35.0	<b>3500S40</b>	□	34.5<D1<35.5	107		142	212	40	
35.5	<b>3550S40</b>	□		107		142	212	40	
36.0	<b>3600S40</b>	□	35.5<D1<36.5	111		147	217	40	
36.5	<b>3650S40</b>	□		111		147	217	40	
37.0	<b>3700S40</b>	□	36.5<D1<37.5	115		152	222	40	
37.5	<b>3750S40</b>	□		115		152	222	40	
38.0	<b>3800S40</b>	□	37.5<D1<38.5	119		157	227	40	
38.5	<b>3850S40</b>	□		119		157	227	40	
39.0	<b>3900S40</b>	□	38.5<D1<39.5	118		157	227	40	
39.5	<b>3950S40</b>	□		118		157	227	40	
40.0	<b>4000S40</b>	□	39.5<D1<40.0	122		162	232	40	

(Примечание 1) Стандартные сверла только для вращения по часовой стрелке.

(Примечание 2) Сверла с диаметрами, указанными в колонке "Диапазон диаметров сверл", производятся по отдельному заказу.

(Примечание 3) Для заказа промежуточных диаметров, пожалуйста, впишите диаметр 4-мя цифрами в поля □□□□ условного обозначения.  
(Например : UP20M BRA2530S32 для диаметра φ25.30 мм)

(Примечание 4) Пожалуйста, свяжитесь с нами, относительно специальных конструкций сверл.

## РЕКОМЕНДУЕМЫЕ РЕЖИМЫ РЕЗАНИЯ

Инструмент	Обрабатываемый материал	Твердость	Диам. сверла $\phi 8.0 - \phi 13.0$		Диам. сверла $\phi 13.0 - \phi 18.0$		Диам. сверла $\geq \phi 18.0$	
			Скорость резания (м/мин)	Подача (мм/об)	Скорость резания (м/мин)	Подача (мм/об)	Скорость резания (м/мин)	Подача (мм/об)
P	Малуглеродистые стали	$\leq 180\text{HB}$	55 (40–65)	0.25 (0.20–0.30)	65 (50–75)	0.30 (0.25–0.35)	75 (60–85)	0.30 (0.25–0.35)
	Углеродистая сталь	180–280HB	50 (35–60)	0.25 (0.20–0.30)	60 (45–70)	0.30 (0.25–0.35)	70 (55–80)	0.30 (0.25–0.35)
	Легированная сталь	280–350HB	40 (30–50)	0.25 (0.20–0.30)	50 (40–60)	0.25 (0.20–0.30)	55 (45–65)	0.27 (0.20–0.30)
M	Нержавеющая сталь	$\leq 200\text{HB}$	30 (20–40)	0.25 (0.20–0.27)	35 (25–45)	0.27 (0.20–0.30)	40 (30–50)	0.30 (0.25–0.35)
	Чугун	Предел прочности $\leq 350\text{MPa}$	60 (40–70)	0.30 (0.25–0.35)	70 (50–80)	0.35 (0.30–0.40)	80 (60–90)	0.40 (0.35–0.45)
K	Ковкий чугун	Предел прочности $\leq 450\text{MPa}$	55 (40–65)	0.27 (0.20–0.30)	60 (45–70)	0.30 (0.25–0.35)	70 (55–80)	0.30 (0.25–0.35)
S	Жаропрочные сплавы	–	15 (10–20)	0.10 (0.05–0.12)	20 (15–25)	0.15 (0.10–0.20)	25 (20–30)	0.15 (0.10–0.20)
	Титановые сплавы	–	20 (10–25)	0.15 (0.10–0.17)	30 (20–35)	0.20 (0.15–0.25)	35 (30–40)	0.25 (0.20–0.30)

(Примечание) Используйте приведенные в таблице режимы резания как первоначальные. Режимы резания корректируются в зависимости от мощности и жесткости станка и формы заготовки.

## СОПРОТИВЛЕНИЕ РЕЗАНИЮ

Заготовка : DIN X5CrNi189 (200HB) Скорость резания : 60м/мин

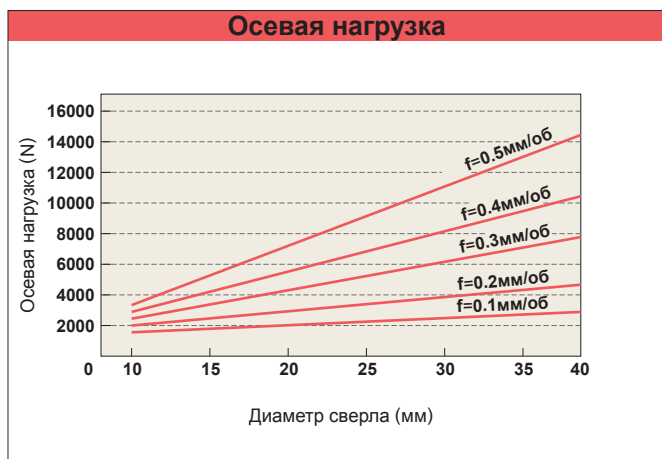
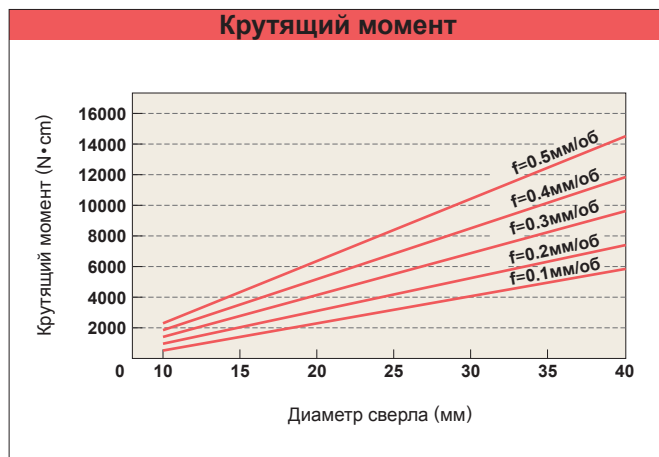
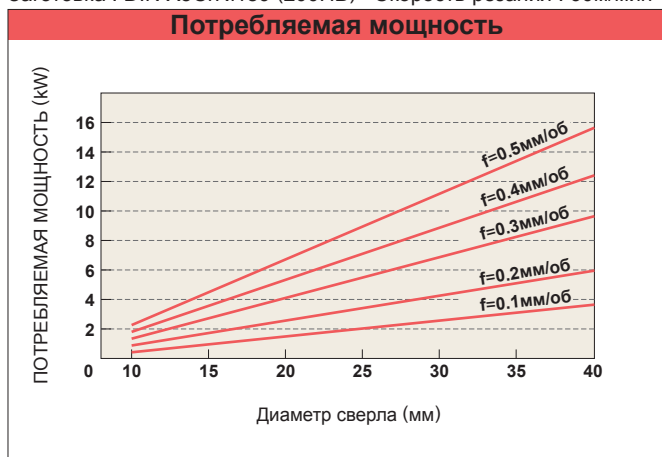

### Причина снижения осевой нагрузки

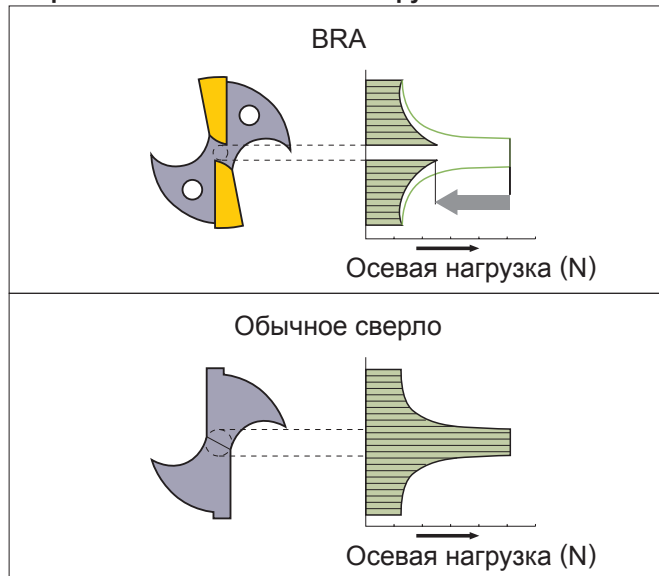

**ОБОЗНАЧЕНИЕ СВЕРЛ  
BRA**

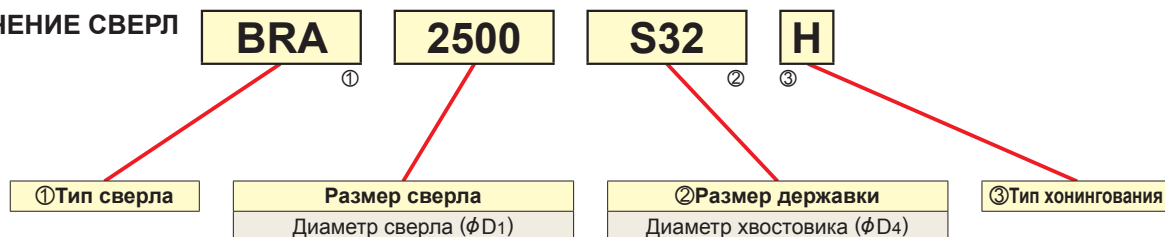

**① Тип сверла**

Тип	Описание						Область применения	Наименование продукции
	Двойной угол в плане	Глубина сверления	Угол подъёма винтовой канавки	Задний угол	Обратный конус	Диам. корпуса		
<b>BRA</b>	150°	l/d=3—4	20°	10°	0.3мм/100мм	øD1-0.2мм	ОБЩЕГО НАЗНАЧЕНИЯ (Графит / Сплавы / Нержавеющая сталь)	BRA○○○○S○○

**② Размер державки**

Тип	Диаметр хвостовика	Диаметр сверла
<b>S16</b>	ø16 (h6)	ø8.0 ≤ D1 ≤ ø14.5
<b>S20</b>	ø20 (h6)	ø14.5 < D1 ≤ ø18.5
<b>S25</b>	ø25 (h6)	ø18.5 < D1 ≤ ø23.5
<b>S32</b>	ø32 (h6)	ø23.5 < D1 ≤ ø30.5
<b>S40</b>	ø40 (h6)	ø30.5 < D1 ≤ ø40.0

**③ Тип хонингования**

Тип	Ширина хонингования (мм)	Обрабатываемый материал
		<b>BRA</b>
<b>-(Стандарт)</b>	0.15—0.2	Углеродистая сталь, Легированная сталь, Малоуглеродистые стали
<b>S</b>	0.2—0.25	—
<b>M</b>	0.25—0.3	—
<b>L</b>	0.3—0.4	—
<b>H</b>	0.05—0.1	Нержавеющая сталь, Жаропрочные сплавы, Титановые сплавы
<b>G</b>	0.025—0.08	Чугун, Алюминиевые сплавы, Цветные Металлы

# VIOLET СВЕРЛА

## VAPDS

Короткая длина рабочей части, Высокая точность



D1 < 2

D1 ≥ 2

Заострение

Углеродистая сталь Легированная сталь	Закалённая сталь	Нержавеющая сталь	Чугун	Лёгкий сплав	Жаропрочные сплавы
◎		○	○		○

0.5 ≤ D1 ≤ 3	3 < D1 ≤ 6	6 < D1 ≤ 10	10 < D1 ≤ 13
0 -0.014	0 -0.018	0 -0.022	0 -0.027

\* Все сверла за исключением сверл с диаметром кратным 0.1 мм и диаметром свыше 1.99 мм имеют допуск 0—0.009 мм.

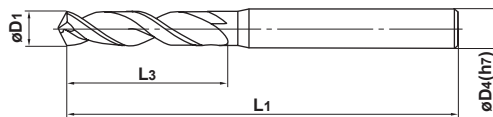

● Благодаря новому покрытию Violet удалось повысить эффективность сверления и улучшить стойкость инструмента. (Стандартная глубина сверления - менее 3 диаметров сверла).

Диам. сверла D1 (мм)	Обозначение	Размеры (мм)			Наличие	Диам. сверла D1 (мм)	Обозначение	Размеры (мм)			Наличие
		L3	L1	D4				L3	L1	D4	
0.5	VAPDSD0050	3	50	3	●	0.9	VAPDSD0090	6	50	3	★
0.51	D0051	3	50	3	★	0.91	D0091	6	50	3	★
0.52	D0052	3	50	3	★	0.92	D0092	6	50	3	★
0.53	D0053	3	50	3	★	0.93	D0093	6	50	3	★
0.54	D0054	3	50	3	★	0.94	D0094	6	50	3	★
0.55	D0055	3	50	3	★	0.95	D0095	6	50	3	★
0.56	D0056	4	50	3	★	0.96	D0096	6	50	3	★
0.57	D0057	4	50	3	★	0.97	D0097	6	50	3	★
0.58	D0058	4	50	3	★	0.98	D0098	6	50	3	★
0.59	D0059	4	50	3	★	0.99	D0099	6	50	3	★
0.6	D0060	5	50	3	★	1.0	D0100	6	50	3	●
0.61	D0061	5	50	3	★	1.01	D0101	6	50	3	★
0.62	D0062	5	50	3	★	1.02	D0102	6	50	3	★
0.63	D0063	5	50	3	★	1.03	D0103	6	50	3	★
0.64	D0064	5	50	3	★	1.04	D0104	6	50	3	★
0.65	D0065	5	50	3	★	1.05	D0105	6	50	3	★
0.66	D0066	5	50	3	★	1.06	D0106	6	50	3	★
0.67	D0067	5	50	3	★	1.07	D0107	8	55	3	★
0.68	D0068	5	50	3	★	1.08	D0108	8	55	3	★
0.69	D0069	5	50	3	★	1.09	D0109	8	55	3	★
0.7	D0070	5	50	3	★	1.1	D0110	8	55	3	★
0.71	D0071	5	50	3	★	1.11	D0111	8	55	3	★
0.72	D0072	5	50	3	★	1.12	D0112	8	55	3	★
0.73	D0073	5	50	3	★	1.13	D0113	8	55	3	★
0.74	D0074	5	50	3	★	1.14	D0114	8	55	3	★
0.75	D0075	5	50	3	★	1.15	D0115	8	55	3	★
0.76	D0076	5	50	3	★	1.16	D0116	8	55	3	★
0.77	D0077	5	50	3	★	1.17	D0117	8	55	3	★
0.78	D0078	5	50	3	★	1.18	D0118	8	55	3	★
0.79	D0079	5	50	3	★	1.19	D0119	8	55	3	★
0.8	D0080	5	50	3	★	1.2	D0120	8	55	3	★
0.81	D0081	5	50	3	★	1.21	D0121	8	55	3	★
0.82	D0082	5	50	3	★	1.22	D0122	8	55	3	★
0.83	D0083	5	50	3	★	1.23	D0123	8	55	3	★
0.84	D0084	5	50	3	★	1.24	D0124	8	55	3	★
0.85	D0085	5	50	3	★	1.25	D0125	8	55	3	★
0.86	D0086	6	50	3	★	1.26	D0126	8	55	3	★
0.87	D0087	6	50	3	★	1.27	D0127	8	55	3	★
0.88	D0088	6	50	3	★	1.28	D0128	8	55	3	★
0.89	D0089	6	50	3	★	1.29	D0129	8	55	3	★

● : Есть на складе. ★ : Со склада в Японии.

Диам. сверла D1 (мм)	Обозначение	Размеры (мм)			Наличие
		L3	L1	D4	
1.3	VAPDSD0130	9	55	3	★
1.31	D0131	9	55	3	★
1.32	D0132	9	55	3	★
1.33	D0133	9	55	3	★
1.34	D0134	9	55	3	★
1.35	D0135	9	55	3	★
1.36	D0136	9	55	3	★
1.37	D0137	9	55	3	★
1.38	D0138	9	55	3	★
1.39	D0139	9	55	3	★
1.4	D0140	9	55	3	★
1.41	D0141	9	55	3	★
1.42	D0142	9	55	3	★
1.43	D0143	9	55	3	★
1.44	D0144	9	55	3	★
1.45	D0145	9	55	3	★
1.46	D0146	9	55	3	★
1.47	D0147	9	55	3	★
1.48	D0148	9	55	3	★
1.49	D0149	9	55	3	★
1.5	D0150	9	55	3	●
1.51	D0151	11	55	3	★
1.52	D0152	11	55	3	★
1.53	D0153	11	55	3	★
1.54	D0154	11	55	3	★
1.55	D0155	11	55	3	★
1.56	D0156	11	55	3	★
1.57	D0157	11	55	3	★
1.58	D0158	11	55	3	★
1.59	D0159	11	55	3	★
1.6	D0160	11	55	3	★
1.61	D0161	11	55	3	★
1.62	D0162	11	55	3	★
1.63	D0163	11	55	3	★
1.64	D0164	11	55	3	★
1.65	D0165	11	55	3	★
1.66	D0166	11	55	3	★
1.67	D0167	11	55	3	★
1.68	D0168	11	55	3	★
1.69	D0169	11	55	3	★
1.7	D0170	11	55	3	★
1.71	D0171	11	55	3	★
1.72	D0172	11	55	3	★
1.73	D0173	11	55	3	★
1.74	D0174	11	55	3	★
1.75	D0175	11	55	3	★
1.76	D0176	11	55	3	★
1.77	D0177	11	55	3	★
1.78	D0178	11	55	3	★
1.79	D0179	11	55	3	★

Диам. сверла D1 (мм)	Обозначение	Размеры (мм)			Наличие
		L3	L1	D4	
1.8	VAPDSD0180	11	55	3	★
1.81	D0181	11	55	3	★
1.82	D0182	11	55	3	★
1.83	D0183	11	55	3	★
1.84	D0184	11	55	3	★
1.85	D0185	11	55	3	★
1.86	D0186	11	55	3	★
1.87	D0187	11	55	3	★
1.88	D0188	11	55	3	★
1.89	D0189	11	55	3	★
1.9	D0190	12	55	3	★
1.91	D0191	12	60	3	★
1.92	D0192	12	60	3	★
1.93	D0193	12	60	3	★
1.94	D0194	12	60	3	★
1.95	D0195	12	60	3	★
1.96	D0196	12	60	3	★
1.97	D0197	12	60	3	★
1.98	D0198	12	60	3	★
1.99	D0199	12	60	3	★
2.0	D0200	12	60	3	●
2.05	D0205	12	60	3	★
2.1	D0210	12	60	3	★
2.15	D0215	12	60	3	★
2.2	D0220	12	60	3	★
2.25	D0225	12	60	3	★
2.3	D0230	13	60	3	★
2.35	D0235	13	60	3	★
2.4	D0240	13	60	3	★
2.45	D0245	13	60	3	★
2.5	D0250	13	60	3	●
2.55	D0255	13	60	3	★
2.6	D0260	15	60	3	★
2.65	D0265	15	60	3	★
2.7	D0270	15	60	3	★
2.75	D0275	15	60	3	★
2.8	D0280	15	60	3	★
2.85	D0285	15	60	3	★
2.9	D0290	15	60	3	★
2.95	D0295	15	60	3	★
3.0	D0300	15	60	3	●
3.05	D0305	17	70	4	★
3.1	D0310	17	70	4	★
3.15	D0315	17	70	4	★
3.2	D0320	17	70	4	★
3.25	D0325	17	70	4	★
3.3	D0330	19	70	4	★
3.35	D0335	19	70	4	★
3.4	D0340	19	70	4	★
3.45	D0345	19	70	4	★

Диам. сверла D1 (мм)	Обозначение	Размеры (мм)			Наличие
		L3	L1	D4	
3.5	VAPDSD0350	19	70	4	●
3.55	D0355	19	70	4	★
3.6	D0360	21	70	4	★
3.65	D0365	21	70	4	★
3.7	D0370	21	70	4	★
3.75	D0375	21	70	4	★
3.8	D0380	21	70	4	★
3.85	D0385	21	70	4	★
3.9	D0390	21	70	4	★
3.95	D0395	21	70	4	★
4.0	D0400	21	70	4	●
4.05	D0405	21	80	6	★
4.1	D0410	21	80	6	★
4.15	D0415	21	80	6	★
4.2	D0420	21	80	6	★
4.25	D0425	21	80	6	★
4.3	D0430	23	80	6	★
4.35	D0435	23	80	6	★
4.4	D0440	23	80	6	★
4.45	D0445	23	80	6	★
4.5	D0450	23	80	6	●
4.55	D0455	23	80	6	★
4.6	D0460	25	80	6	★
4.65	D0465	25	80	6	★
4.7	D0470	25	80	6	★
4.75	D0475	25	80	6	★
4.8	D0480	25	80	6	★
4.85	D0485	25	80	6	★
4.9	D0490	25	80	6	★
4.95	D0495	25	80	6	★
5.0	D0500	25	80	6	●
5.05	D0505	25	80	6	★
5.1	D0510	25	80	6	★
5.15	D0515	25	80	6	★
5.2	D0520	25	80	6	★
5.25	D0525	25	80	6	★
5.3	D0530	25	80	6	★
5.35	D0535	27	80	6	★
5.4	D0540	27	80	6	★
5.45	D0545	27	80	6	★
5.5	D0550	27	80	6	●
5.55	D0555	27	80	6	★
5.6	D0560	27	80	6	★
5.65	D0565	27	80	6	★
5.7	D0570	27	80	6	★
5.75	D0575	27	80	6	★
5.8	D0580	27	80	6	★
5.85	D0585	27	80	6	★
5.9	D0590	27	80	6	★
5.95	D0595	27	80	6	★

Диам. сверла D1 (мм)	Обозначение	Размеры (мм)			Наличие
		L3	L1	D4	
6.0	VAPDSD0600	27	80	6	●
6.05	D0605	30	80	8	★
6.1	D0610	30	80	8	★
6.15	D0615	30	80	8	★
6.2	D0620	30	80	8	★
6.25	D0625	30	80	8	★
6.3	D0630	30	80	8	★
6.35	D0635	30	80	8	★
6.4	D0640	30	80	8	★
6.45	D0645	30	80	8	★
6.5	D0650	30	80	8	●
6.55	D0655	30	80	8	★
6.6	D0660	30	80	8	★
6.65	D0665	30	80	8	★
6.7	D0670	30	80	8	★
6.75	D0675	32	80	8	★
6.8	D0680	32	80	8	★
6.85	D0685	32	80	8	★
6.9	D0690	32	80	8	★
6.95	D0695	32	80	8	★
7.0	D0700	32	80	8	●
7.05	D0705	32	80	8	★
7.1	D0710	32	80	8	★
7.15	D0715	32	80	8	★
7.2	D0720	32	80	8	★
7.25	D0725	32	80	8	★
7.3	D0730	32	80	8	★
7.35	D0735	32	80	8	★
7.4	D0740	32	80	8	★
7.45	D0745	32	80	8	★
7.5	D0750	32	80	8	●
7.55	D0755	35	85	8	★
7.6	D0760	35	85	8	★
7.65	D0765	35	85	8	★
7.7	D0770	35	85	8	★
7.75	D0775	35	85	8	★
7.8	D0780	35	85	8	★
7.85	D0785	35	85	8	★
7.9	D0790	35	85	8	★
7.95	D0795	35	85	8	★
8.0	D0800	35	85	8	●
8.05	D0805	35	90	10	★
8.1	D0810	35	90	10	★
8.15	D0815	35	90	10	★
8.2	D0820	35	90	10	★
8.25	D0825	35	90	10	★
8.3	D0830	35	90	10	★
8.35	D0835	35	90	10	★
8.4	D0840	35	90	10	★
8.45	D0845	35	90	10	★

● : Есть на складе. ★ : Со склада в Японии.

Диам. сверла D1 (мм)	Обозначение	Размеры (мм)			Наличие
		L3	L1	D4	
8.5	VAPDSD0850	35	90	10	●
8.55	D0855	38	93	10	★
8.6	D0860	38	93	10	★
8.65	D0865	38	93	10	★
8.7	D0870	38	93	10	★
8.75	D0875	38	93	10	★
8.8	D0880	38	93	10	★
8.85	D0885	38	93	10	★
8.9	D0890	38	93	10	★
8.95	D0895	38	93	10	★
9.0	D0900	38	93	10	●
9.05	D0905	38	93	10	★
9.1	D0910	38	93	10	★
9.15	D0915	38	93	10	★
9.2	D0920	38	93	10	★
9.25	D0925	38	93	10	★
9.3	D0930	38	93	10	★
9.35	D0935	38	93	10	★
9.4	D0940	38	93	10	★
9.45	D0945	38	93	10	★
9.5	D0950	38	93	10	●
9.55	D0955	41	96	10	★
9.6	D0960	41	96	10	★
9.65	D0965	41	96	10	★
9.7	D0970	41	96	10	★
9.75	D0975	41	96	10	★
9.8	D0980	41	96	10	★
9.85	D0985	41	96	10	★
9.9	D0990	41	96	10	★
9.95	D0995	41	96	10	★
10.0	D1000	41	96	10	●
10.05	D1005	41	101	12	★
10.1	D1010	41	101	12	★
10.15	D1015	41	101	12	★
10.2	D1020	41	101	12	★
10.25	D1025	41	101	12	★
10.3	D1030	41	101	12	★
10.35	D1035	41	101	12	★
10.4	D1040	41	101	12	★
10.45	D1045	41	101	12	★
10.5	D1050	41	101	12	●
10.55	D1055	41	101	12	★
10.6	D1060	41	101	12	★
10.65	D1065	45	105	12	★
10.7	D1070	45	105	12	★
10.75	D1075	45	105	12	★
10.8	D1080	45	105	12	★
10.85	D1085	45	105	12	★
10.9	D1090	45	105	12	★
10.95	D1095	45	105	12	★

Диам. сверла D1 (мм)	Обозначение	Размеры (мм)			Наличие
		L3	L1	D4	
11.0	VAPDSD1100	45	105	12	●
11.05	D1105	45	105	12	★
11.1	D1110	45	105	12	★
11.15	D1115	45	105	12	★
11.2	D1120	45	105	12	★
11.25	D1125	45	105	12	★
11.3	D1130	45	105	12	★
11.35	D1135	45	105	12	★
11.4	D1140	45	105	12	★
11.45	D1145	45	105	12	★
11.5	D1150	45	105	12	★
11.55	D1155	45	105	12	★
11.6	D1160	45	105	12	★
11.65	D1165	45	105	12	★
11.7	D1170	45	105	12	★
11.75	D1175	45	105	12	★
11.8	D1180	45	105	12	★
11.85	D1185	49	109	12	★
11.9	D1190	49	109	12	★
11.95	D1195	49	109	12	★
12.0	D1200	49	109	12	●
12.1	D1210	49	109	12	★
12.2	D1220	49	109	12	★
12.3	D1230	49	109	12	★
12.4	D1240	49	109	12	★
12.5	D1250	49	109	12	●
12.6	D1260	49	109	12	★
12.7	D1270	49	109	12	★
12.8	D1280	49	109	12	★
12.9	D1290	49	109	12	★
13.0	D1300	49	109	12	★

### РЕКОМЕНДУЕМЫЕ РЕЖИМЫ РЕЗАНИЯ (Стандартная глубина сверления : равна 3 диаметрам сверла или меньше)

Обработываемый материал	Конструкционная сталь		Углеродистая сталь S <sub>k</sub> 55 Легированная сталь 070M55 Чугун		Легированная инструментальная сталь X210Cr12 (Материалы низкой твердости) Ферритная нержавеющая сталь X10CrAl18, X10CrAl13 Мартенситная нержавеющая сталь X20Cr13, X10CrAl13		Легированная инструментальная сталь X40CrMoV51 (-40HRC) Нержавеющая сталь с дисперсионным упрочнением X7CrNiAl177	
	Диам. сверла (мм)	Частота вращения (мин <sup>-1</sup> )	Подача (мм/об)	Частота вращения (мин <sup>-1</sup> )	Подача (мм/об)	Частота вращения (мин <sup>-1</sup> )	Подача (мм/об)	Частота вращения (мин <sup>-1</sup> )
<b>0.5</b>	18000	0.02	16000	0.02	9000	0.02	8200	0.02
<b>1.0</b>	12000	0.05	10000	0.05	6300	0.05	5500	0.04
<b>2.0</b>	6400	0.09	5500	0.09	3200	0.09	2900	0.05
<b>3.0</b>	4300	0.13	3700	0.13	2100	0.13	1900	0.06
<b>4.0</b>	3200	0.15	2800	0.15	1600	0.15	1400	0.08
<b>5.0</b>	2600	0.18	2200	0.18	1300	0.18	1100	0.10
<b>6.0</b>	2100	0.19	1800	0.19	1100	0.20	950	0.11
<b>8.0</b>	1600	0.24	1400	0.24	800	0.22	720	0.13
<b>10.0</b>	1300	0.28	1100	0.28	640	0.25	570	0.15
<b>12.0</b>	1100	0.34	930	0.34	530	0.30	480	0.17
<b>13.0</b>	980	0.36	860	0.36	490	0.32	440	0.19

- 1) Пожалуйста, снизьте обороты и подачу при недостаточной жесткости закрепленной детали или ограничениях станка.
- 2) Пожалуйста, используйте сверлильную или фрезерную оправку цангового типа.
- 3) Используйте достаточное количество СОЖ.
- 4) Сверла VAPDSSUS и VAPDMSUS рекомендуется использовать для обработки аустенитных нержавеющих сталей (Например X5CrNi1810).
- 5) При сверлении отверстий глубиной более 4 x D сверла, используйте подачу с периодическим выводом сверла из отверстия.

Вышеупомянутые режимы резания указаны для обработки с СОЖ.  
Пожалуйста, снизьте обороты при обработке без СОЖ.

# VAPDM

Средняя длина рабочей части, Высокая точность



Быстрорежущая  
сталь

Углеродистая сталь Легированная сталь	Закалённая сталь	Нержавеющая сталь	Чугун	Лёгкий сплав	Жаропрочные сплавы
○		○	○		○

$0.5 \leq D_1 \leq 3$	$3 < D_1 \leq 6$	$6 < D_1 \leq 10$	$10 < D_1 \leq 18$	$18 < D_1 \leq 30$	$30 < D_1 \leq 32$
$0$ -0.014	$0$ -0.018	$0$ -0.022	$0$ -0.027	$0$ -0.033	$0$ -0.039

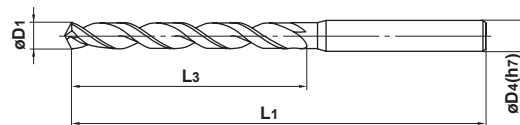

- Благодаря новому покрытию Violet удалось повысить эффективность сверления и улучшить стойкость инструмента. (Стандартная глубина сверления - менее 5 диаметров сверла).

Диам. сверла D1 (мм)	Обозначение	Размеры (мм)			Наличие
		L3	L1	D4	
0.5	VAPDMD0050	6	50	3	●
0.55	D0055	6	50	3	★
0.6	D0060	8	50	3	★
0.65	D0065	8	50	3	★
0.7	D0070	10	50	3	★
0.75	D0075	10	50	3	★
0.8	D0080	10	50	3	★
0.85	D0085	10	50	3	★
0.9	D0090	12	50	3	★
0.95	D0095	12	50	3	★
1.0	D0100	12	60	3	●
1.05	D0105	12	60	3	★
1.1	D0110	16	60	3	★
1.15	D0115	16	60	3	★
1.2	D0120	16	60	3	★
1.25	D0125	16	60	3	★
1.3	D0130	16	60	3	★
1.35	D0135	18	60	3	★
1.4	D0140	18	60	3	★
1.45	D0145	18	60	3	★
1.5	D0150	18	60	3	●
1.55	D0155	20	60	3	★
1.6	D0160	20	60	3	★
1.65	D0165	20	60	3	★
1.7	D0170	20	60	3	★
1.75	D0175	20	60	3	★
1.8	D0180	22	60	3	★
1.85	D0185	22	60	3	★
1.9	D0190	22	60	3	★
1.95	D0195	23	60	3	★
2.0	D0200	23	70	3	●
2.05	D0205	23	70	3	★
2.1	D0210	23	70	3	★
2.15	D0215	23	70	3	★
2.2	D0220	26	70	3	★
2.25	D0225	26	70	3	★
2.3	D0230	26	70	3	★
2.35	D0235	26	70	3	★
2.4	D0240	29	70	3	★
2.45	D0245	29	70	3	★

Диам. сверла D1 (мм)	Обозначение	Размеры (мм)			Наличие
		L3	L1	D4	
2.5	VAPDMD0250	29	70	3	●
2.55	D0255	29	70	3	★
2.6	D0260	29	70	3	★
2.65	D0265	29	70	3	★
2.7	D0270	32	70	3	★
2.75	D0275	32	70	3	★
2.8	D0280	32	70	3	★
2.85	D0285	32	70	3	★
2.9	D0290	32	70	3	★
2.95	D0295	32	70	3	★
3.0	D0300	32	70	3	●
3.05	D0305	35	85	4	★
3.1	D0310	35	85	4	★
3.15	D0315	35	85	4	★
3.2	D0320	35	85	4	★
3.25	D0325	35	85	4	★
3.3	D0330	35	85	4	★
3.35	D0335	35	85	4	★
3.4	D0340	38	85	4	★
3.45	D0345	38	85	4	★
3.5	D0350	38	85	4	●
3.55	D0355	38	85	4	★
3.6	D0360	38	85	4	★
3.65	D0365	38	85	4	★
3.7	D0370	38	85	4	★
3.75	D0375	42	85	4	★
3.8	D0380	42	85	4	★
3.85	D0385	42	85	4	★
3.9	D0390	42	85	4	★
3.95	D0395	42	85	4	★
4.0	D0400	42	85	4	●
4.05	D0405	42	100	6	★
4.1	D0410	42	100	6	★
4.15	D0415	42	100	6	★
4.2	D0420	42	100	6	★
4.25	D0425	46	100	6	★
4.3	D0430	46	100	6	★
4.35	D0435	46	100	6	★
4.4	D0440	46	100	6	★
4.45	D0445	46	100	6	★

СВЕРЛЕНИЕ

● : Есть на складе. ★ : Со склада в Японии.

Диам. сверла D1 (мм)	Обозначение	Размеры (мм)			Наличие	Диам. сверла D1 (мм)	Обозначение	Размеры (мм)			Наличие
		L3	L1	D4				L3	L1	D4	
4.5	VAPDMD0450	46	100	6	●	7.0	VAPDMD0700	67	117	8	●
4.55	D0455	46	100	6	★	7.05	D0705	67	117	8	★
4.6	D0460	46	100	6	★	7.1	D0710	67	117	8	★
4.65	D0465	46	100	6	★	7.15	D0715	67	117	8	★
4.7	D0470	46	100	6	★	7.2	D0720	67	117	8	★
4.75	D0475	46	100	6	★	7.25	D0725	67	117	8	★
4.8	D0480	51	100	6	★	7.3	D0730	67	117	8	★
4.85	D0485	51	100	6	★	7.35	D0735	67	117	8	★
4.9	D0490	51	100	6	★	7.4	D0740	67	117	8	★
4.95	D0495	51	100	6	★	7.45	D0745	67	117	8	★
5.0	D0500	51	100	6	●	7.5	D0750	67	117	8	●
5.05	D0505	51	100	6	★	7.55	D0755	73	123	8	★
5.1	D0510	51	100	6	★	7.6	D0760	73	123	8	★
5.15	D0515	51	100	6	★	7.65	D0765	73	123	8	★
5.2	D0520	51	100	6	★	7.7	D0770	73	123	8	★
5.25	D0525	51	100	6	★	7.75	D0775	73	123	8	★
5.3	D0530	51	100	6	★	7.8	D0780	73	123	8	★
5.35	D0535	56	106	6	★	7.85	D0785	73	123	8	★
5.4	D0540	56	106	6	★	7.9	D0790	73	123	8	★
5.45	D0545	56	106	6	★	7.95	D0795	73	123	8	★
5.5	D0550	56	106	6	●	8.0	D0800	73	123	8	●
5.55	D0555	56	106	6	★	8.05	D0805	73	128	10	★
5.6	D0560	56	106	6	★	8.1	D0810	73	128	10	★
5.65	D0565	56	106	6	★	8.15	D0815	73	128	10	★
5.7	D0570	56	106	6	★	8.2	D0820	73	128	10	★
5.75	D0575	56	106	6	★	8.25	D0825	73	128	10	★
5.8	D0580	56	106	6	★	8.3	D0830	73	128	10	★
5.85	D0585	56	106	6	★	8.35	D0835	73	128	10	★
5.9	D0590	56	106	6	★	8.4	D0840	73	128	10	★
5.95	D0595	56	106	6	★	8.45	D0845	73	128	10	★
6.0	D0600	56	106	6	●	8.5	D0850	73	128	10	●
6.05	D0605	62	112	8	★	8.55	D0855	79	134	10	★
6.1	D0610	62	112	8	★	8.6	D0860	79	134	10	★
6.15	D0615	62	112	8	★	8.65	D0865	79	134	10	★
6.2	D0620	62	112	8	★	8.7	D0870	79	134	10	★
6.25	D0625	62	112	8	★	8.75	D0875	79	134	10	★
6.3	D0630	62	112	8	★	8.8	D0880	79	134	10	★
6.35	D0635	62	112	8	★	8.85	D0885	79	134	10	★
6.4	D0640	62	112	8	★	8.9	D0890	79	134	10	★
6.45	D0645	62	112	8	★	8.95	D0895	79	134	10	★
6.5	D0650	62	112	8	●	9.0	D0900	79	134	10	●
6.55	D0655	62	112	8	★	9.1	D0910	79	134	10	★
6.6	D0660	62	112	8	★	9.2	D0920	79	134	10	★
6.65	D0665	62	112	8	★	9.3	D0930	79	134	10	★
6.7	D0670	62	112	8	★	9.4	D0940	79	134	10	★
6.75	D0675	67	117	8	★	9.5	D0950	79	134	10	●
6.8	D0680	67	117	8	★	9.6	D0960	85	140	10	★
6.85	D0685	67	117	8	★	9.7	D0970	85	140	10	★
6.9	D0690	67	117	8	★	9.8	D0980	85	140	10	★
6.95	D0695	67	117	8	★	9.9	D0990	85	140	10	★

● : Есть на складе. ★ : Со склада в Японии.

Диам. сверла D1 (мм)	Обозначение	Размеры (мм)			Наличие
		L3	L1	D4	
10.0	VAPDMD1000	85	140	10	●
10.1	D1010	85	145	12	★
10.2	D1020	85	145	12	★
10.3	D1030	85	145	12	★
10.4	D1040	85	145	12	★
10.5	D1050	85	145	12	●
10.6	D1060	85	145	12	★
10.7	D1070	92	152	12	★
10.8	D1080	92	152	12	★
10.9	D1090	92	152	12	★
11.0	D1100	92	152	12	●
11.1	D1110	92	152	12	★
11.2	D1120	92	152	12	★
11.3	D1130	92	152	12	★
11.4	D1140	92	152	12	★
11.5	D1150	92	152	12	●
11.6	D1160	92	152	12	★
11.7	D1170	92	152	12	★
11.8	D1180	92	152	12	★
11.9	D1190	99	159	12	★
12.0	D1200	99	159	12	●
12.1	D1210	99	159	12	★
12.2	D1220	99	159	12	★
12.3	D1230	99	159	12	★
12.4	D1240	99	159	12	★
12.5	D1250	99	159	12	●
12.6	D1260	99	159	12	★
12.7	D1270	99	159	12	★
12.8	D1280	99	159	12	★
12.9	D1290	99	159	12	★
13.0	D1300	99	159	12	●
13.5	D1350	100	160	16	●
14.0	D1400	100	160	16	●
14.1	D1410	105	165	16	★
14.2	D1420	105	165	16	★
14.5	D1450	105	165	16	●
15.0	D1500	105	165	16	●
15.5	D1550	110	170	16	★
15.6	D1560	110	170	16	★
15.7	D1570	110	170	16	★
16.0	D1600	110	170	16	●
16.5	D1650	110	175	20	●
17.0	D1700	110	175	20	●
17.5	D1750	115	180	20	●
17.6	D1760	115	180	20	★
17.7	D1770	115	180	20	★
18.0	D1800	115	180	20	●
18.5	D1850	120	185	20	★
19.0	D1900	120	185	20	★
19.5	D1950	120	185	20	★

Диам. сверла D1 (мм)	Обозначение	Размеры (мм)			Наличие
		L3	L1	D4	
19.6	VAPDMD1960	120	185	20	★
19.7	D1970	120	185	20	★
20.0	D2000	120	185	20	★
20.5	D2050	125	200	25	●
21.0	D2100	125	200	25	●
21.1	D2110	125	200	25	★
21.2	D2120	125	200	25	★
21.5	D2150	125	200	25	★
22.0	D2200	125	200	25	●
22.5	D2250	130	205	25	★
23.0	D2300	130	205	25	●
23.5	D2350	130	205	25	★
24.0	D2400	135	210	25	★
24.5	D2450	135	210	25	★
25.0	D2500	135	210	25	★
25.5	D2550	140	220	32	●
26.0	D2600	140	220	32	★
26.5	D2650	140	220	32	★
27.0	D2700	140	220	32	★
28.0	D2800	140	220	32	★
29.0	D2900	145	225	32	★
30.0	D3000	145	225	32	★
31.0	D3100	150	230	32	★
32.0	D3200	155	235	32	★

### РЕКОМЕНДУЕМЫЕ РЕЖИМЫ РЕЗАНИЯ (Стандартная глубина сверления : равна 5 диаметрам сверла или меньше)

Обработываемый материал	Конструкционная сталь		Углеродистая сталь Сk55 Легированная сталь 070M55 Чугун		Легированная инструментальная сталь X210Cr12 (Материалы низкой твердости) Ферритная нержавеющая сталь X10CrAl18, X10CrAl13 Мартенситная нержавеющая сталь X20Cr13, X10CrAl13		Легированная инструментальная сталь X40CrMoV51 (-40HRC) Нержавеющая сталь с дисперсионным упрочнением X7CrNiAl177	
	Диам. сверла (мм)	Частота вращения (мин <sup>-1</sup> )	Подача (мм/об)	Частота вращения (мин <sup>-1</sup> )	Подача (мм/об)	Частота вращения (мин <sup>-1</sup> )	Подача (мм/об)	Частота вращения (мин <sup>-1</sup> )
<b>0.5</b>	17000	0.01	12800	0.01	8000	0.01	6600	0.01
<b>1.0</b>	11000	0.05	8300	0.05	5000	0.05	4100	0.04
<b>2.0</b>	6400	0.09	4800	0.09	2900	0.06	2400	0.05
<b>3.0</b>	4300	0.13	3200	0.13	1900	0.10	1600	0.06
<b>4.0</b>	3200	0.15	2400	0.15	1400	0.10	1200	0.08
<b>5.0</b>	2600	0.18	1900	0.18	1100	0.13	950	0.10
<b>6.0</b>	2100	0.19	1600	0.20	950	0.15	800	0.11
<b>8.0</b>	1600	0.24	1200	0.22	720	0.18	600	0.13
<b>10.0</b>	1300	0.28	950	0.25	570	0.21	480	0.15
<b>12.0</b>	1100	0.34	800	0.30	480	0.25	400	0.17
<b>14.0</b>	910	0.39	680	0.35	410	0.30	340	0.21
<b>15.0</b>	850	0.40	640	0.36	380	0.31	320	0.22
<b>16.0</b>	800	0.42	600	0.38	360	0.32	300	0.23
<b>18.0</b>	710	0.44	530	0.40	320	0.34	270	0.24
<b>20.0</b>	570	0.44	450	0.40	250	0.34	220	0.24
<b>22.0</b>	520	0.46	410	0.42	230	0.36	200	0.25
<b>24.0</b>	480	0.48	370	0.44	210	0.37	190	0.26
<b>26.0</b>	440	0.51	340	0.46	200	0.39	170	0.28
<b>28.0</b>	410	0.53	320	0.48	180	0.41	160	0.29
<b>30.0</b>	380	0.55	300	0.50	170	0.43	150	0.30
<b>32.0</b>	360	0.55	280	0.50	160	0.43	140	0.30

- 1) Пожалуйста, снизьте обороты и подачу при недостаточной жесткости закрепленной детали или ограничениях станка.
- 2) Пожалуйста, используйте сверлильную или фрезерную оправку цангового типа.
- 3) Используйте достаточное количество СОЖ.
- 4) Сверла VAPDSSUS и VAPDMSUS рекомендуется использовать для обработки аустенитных нержавеющих сталей (Например X5CrNi1810).
- 5) При сверлении отверстий глубиной более 4 x D сверла, используйте подачу с периодическим выводом сверла из отверстия.

Вышеупомянутые режимы резания указаны для обработки с СОЖ.  
Пожалуйста, снизьте обороты при обработке без СОЖ.

Углеродистая сталь Легированная сталь	Закалённая сталь	Нержавеющая сталь	Чугун	Лёгкий сплав	Жаропрочные сплавы
○		◎	○	○	

0.5 ≤ D1 ≤ 3	3 < D1 ≤ 6	6 < D1 ≤ 10	10 < D1 ≤ 18	18 < D1 ≤ 20
<sup>0</sup> / <sub>-0.014</sub>	<sup>0</sup> / <sub>-0.018</sub>	<sup>0</sup> / <sub>-0.022</sub>	<sup>0</sup> / <sub>-0.027</sub>	<sup>0</sup> / <sub>-0.033</sub>

\* Все сверла за исключением сверл с диаметром кратным 0.1 мм и диаметром свыше 4.0 мм имеют допуск 0—-0.009 мм.

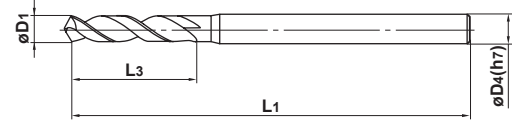

● Сочетание новой геометрии и покрытия Violet обеспечивает эффективное сверление и высокую стойкость при обработке нержавеющей сталей.

Диам. сверла D1 (мм)	Обозначение	Размеры (мм)			Наличие
		L3	L1	D4	
0.5	VAPDSSUSD0050	3	50	3	●
0.51	D0051	3	50	3	★
0.52	D0052	3	50	3	★
0.53	D0053	3	50	3	★
0.54	D0054	3	50	3	★
0.55	D0055	3	50	3	★
0.56	D0056	4	50	3	★
0.57	D0057	4	50	3	★
0.58	D0058	4	50	3	★
0.59	D0059	4	50	3	★
0.6	D0060	5	50	3	★
0.61	D0061	5	50	3	★
0.62	D0062	5	50	3	★
0.63	D0063	5	50	3	★
0.64	D0064	5	50	3	★
0.65	D0065	5	50	3	★
0.66	D0066	5	50	3	★
0.67	D0067	5	50	3	★
0.68	D0068	5	50	3	★
0.69	D0069	5	50	3	★
0.7	D0070	5	50	3	★
0.71	D0071	5	50	3	★
0.72	D0072	5	50	3	★
0.73	D0073	5	50	3	★
0.74	D0074	5	50	3	★
0.75	D0075	5	50	3	★
0.76	D0076	5	50	3	★
0.77	D0077	5	50	3	★
0.78	D0078	5	50	3	★
0.79	D0079	5	50	3	★
0.8	D0080	5	50	3	★
0.81	D0081	5	50	3	★
0.82	D0082	5	50	3	★
0.83	D0083	5	50	3	★
0.84	D0084	5	50	3	★
0.85	D0085	5	50	3	★
0.86	D0086	6	50	3	★
0.87	D0087	6	50	3	★
0.88	D0088	6	50	3	★
0.89	D0089	6	50	3	★

Диам. сверла D1 (мм)	Обозначение	Размеры (мм)			Наличие
		L3	L1	D4	
0.9	VAPDSSUSD0090	6	50	3	●
0.91	D0091	6	50	3	★
0.92	D0092	6	50	3	★
0.93	D0093	6	50	3	★
0.94	D0094	6	50	3	★
0.95	D0095	6	50	3	★
0.96	D0096	6	50	3	★
0.97	D0097	6	50	3	★
0.98	D0098	6	50	3	★
0.99	D0099	6	50	3	★
1.0	D0100	6	50	3	●
1.01	D0101	6	50	3	★
1.02	D0102	6	50	3	★
1.03	D0103	6	50	3	★
1.04	D0104	6	50	3	★
1.05	D0105	6	50	3	★
1.06	D0106	6	50	3	★
1.07	D0107	8	55	3	★
1.08	D0108	8	55	3	★
1.09	D0109	8	55	3	★
1.1	D0110	8	55	3	★
1.11	D0111	8	55	3	★
1.12	D0112	8	55	3	★
1.13	D0113	8	55	3	★
1.14	D0114	8	55	3	★
1.15	D0115	8	55	3	★
1.16	D0116	8	55	3	★
1.17	D0117	8	55	3	★
1.18	D0118	8	55	3	★
1.19	D0119	8	55	3	★
1.2	D0120	8	55	3	★
1.21	D0121	8	55	3	★
1.22	D0122	8	55	3	★
1.23	D0123	8	55	3	★
1.24	D0124	8	55	3	★
1.25	D0125	8	55	3	★
1.26	D0126	8	55	3	★
1.27	D0127	8	55	3	★
1.28	D0128	8	55	3	★
1.29	D0129	8	55	3	★

СВЕРЛЕНИЕ

● : Есть на складе. ★ : Со склада в Японии.

Диам. сверла D1 (мм)	Обозначение	Размеры (мм)			Наличие
		L3	L1	D4	
1.3	VAPDSSUSD0130	9	55	3	★
1.31	D0131	9	55	3	★
1.32	D0132	9	55	3	★
1.33	D0133	9	55	3	★
1.34	D0134	9	55	3	★
1.35	D0135	9	55	3	★
1.36	D0136	9	55	3	★
1.37	D0137	9	55	3	★
1.38	D0138	9	55	3	★
1.39	D0139	9	55	3	★
1.4	D0140	9	55	3	★
1.41	D0141	9	55	3	★
1.42	D0142	9	55	3	★
1.43	D0143	9	55	3	★
1.44	D0144	9	55	3	★
1.45	D0145	9	55	3	★
1.46	D0146	9	55	3	★
1.47	D0147	9	55	3	★
1.48	D0148	9	55	3	★
1.49	D0149	9	55	3	★
1.5	D0150	9	55	3	●
1.51	D0151	11	55	3	★
1.52	D0152	11	55	3	★
1.53	D0153	11	55	3	★
1.54	D0154	11	55	3	★
1.55	D0155	11	55	3	★
1.56	D0156	11	55	3	★
1.57	D0157	11	55	3	★
1.58	D0158	11	55	3	★
1.59	D0159	11	55	3	★
1.6	D0160	11	55	3	★
1.61	D0161	11	55	3	★
1.62	D0162	11	55	3	★
1.63	D0163	11	55	3	★
1.64	D0164	11	55	3	★
1.65	D0165	11	55	3	★
1.66	D0166	11	55	3	★
1.67	D0167	11	55	3	★
1.68	D0168	11	55	3	★
1.69	D0169	11	55	3	★
1.7	D0170	11	55	3	★
1.71	D0171	11	55	3	★
1.72	D0172	11	55	3	★
1.73	D0173	11	55	3	★
1.74	D0174	11	55	3	★
1.75	D0175	11	55	3	★
1.76	D0176	11	55	3	★
1.77	D0177	11	55	3	★
1.78	D0178	11	55	3	★
1.79	D0179	11	55	3	★

Диам. сверла D1 (мм)	Обозначение	Размеры (мм)			Наличие
		L3	L1	D4	
1.8	VAPDSSUSD0180	11	55	3	★
1.81	D0181	11	55	3	★
1.82	D0182	11	55	3	★
1.83	D0183	11	55	3	★
1.84	D0184	11	55	3	★
1.85	D0185	11	55	3	★
1.86	D0186	11	55	3	★
1.87	D0187	11	55	3	★
1.88	D0188	11	55	3	★
1.89	D0189	11	55	3	★
1.9	D0190	12	55	3	★
1.91	D0191	12	60	3	★
1.92	D0192	12	60	3	★
1.93	D0193	12	60	3	★
1.94	D0194	12	60	3	★
1.95	D0195	12	60	3	★
1.96	D0196	12	60	3	★
1.97	D0197	12	60	3	★
1.98	D0198	12	60	3	★
1.99	D0199	12	60	3	★
2.0	D0200	12	60	3	●
2.01	D0201	12	60	3	★
2.02	D0202	12	60	3	★
2.03	D0203	12	60	3	★
2.04	D0204	12	60	3	★
2.05	D0205	12	60	3	★
2.06	D0206	12	60	3	★
2.07	D0207	12	60	3	★
2.08	D0208	12	60	3	★
2.09	D0209	12	60	3	★
2.1	D0210	12	60	3	★
2.11	D0211	12	60	3	★
2.12	D0212	12	60	3	★
2.13	D0213	12	60	3	★
2.14	D0214	12	60	3	★
2.15	D0215	12	60	3	★
2.16	D0216	12	60	3	★
2.17	D0217	12	60	3	★
2.18	D0218	12	60	3	★
2.19	D0219	12	60	3	★
2.2	D0220	12	60	3	★
2.21	D0221	12	60	3	★
2.22	D0222	12	60	3	★
2.23	D0223	12	60	3	★
2.24	D0224	12	60	3	★
2.25	D0225	12	60	3	★
2.26	D0226	12	60	3	★
2.27	D0227	12	60	3	★
2.28	D0228	12	60	3	★
2.29	D0229	12	60	3	★

● : Есть на складе. ★ : Со склада в Японии.

Диам. сверла D1 (мм)	Обозначение	Размеры (мм)			Наличие
		L3	L1	D4	
2.3	VAPDSSUSD0230	13	60	3	★
2.31	D0231	13	60	3	★
2.32	D0232	13	60	3	★
2.33	D0233	13	60	3	★
2.34	D0234	13	60	3	★
2.35	D0235	13	60	3	★
2.36	D0236	13	60	3	★
2.37	D0237	13	60	3	★
2.38	D0238	13	60	3	★
2.39	D0239	13	60	3	★
2.4	D0240	13	60	3	★
2.41	D0241	13	60	3	★
2.42	D0242	13	60	3	★
2.43	D0243	13	60	3	★
2.44	D0244	13	60	3	★
2.45	D0245	13	60	3	★
2.46	D0246	13	60	3	★
2.47	D0247	13	60	3	★
2.48	D0248	13	60	3	★
2.49	D0249	13	60	3	★
2.5	D0250	13	60	3	●
2.51	D0251	13	60	3	★
2.52	D0252	13	60	3	★
2.53	D0253	13	60	3	★
2.54	D0254	13	60	3	★
2.55	D0255	13	60	3	★
2.56	D0256	13	60	3	★
2.57	D0257	13	60	3	★
2.58	D0258	13	60	3	★
2.59	D0259	13	60	3	★
2.6	D0260	15	60	3	★
2.61	D0261	15	60	3	★
2.62	D0262	15	60	3	★
2.63	D0263	15	60	3	★
2.64	D0264	15	60	3	★
2.65	D0265	15	60	3	★
2.66	D0266	15	60	3	★
2.67	D0267	15	60	3	★
2.68	D0268	15	60	3	★
2.69	D0269	15	60	3	★
2.7	D0270	15	60	3	★
2.71	D0271	15	60	3	★
2.72	D0272	15	60	3	★
2.73	D0273	15	60	3	★
2.74	D0274	15	60	3	★
2.75	D0275	15	60	3	★
2.76	D0276	15	60	3	★
2.77	D0277	15	60	3	★
2.78	D0278	15	60	3	★
2.79	D0279	15	60	3	★

Диам. сверла D1 (мм)	Обозначение	Размеры (мм)			Наличие
		L3	L1	D4	
2.8	VAPDSSUSD0280	15	60	3	★
2.81	D0281	15	60	3	★
2.82	D0282	15	60	3	★
2.83	D0283	15	60	3	★
2.84	D0284	15	60	3	★
2.85	D0285	15	60	3	★
2.86	D0286	15	60	3	★
2.87	D0287	15	60	3	★
2.88	D0288	15	60	3	★
2.89	D0289	15	60	3	★
2.9	D0290	15	60	3	★
2.91	D0291	15	60	3	★
2.92	D0292	15	60	3	★
2.93	D0293	15	60	3	★
2.94	D0294	15	60	3	★
2.95	D0295	15	60	3	★
2.96	D0296	15	60	3	★
2.97	D0297	15	60	3	★
2.98	D0298	15	60	3	★
2.99	D0299	15	60	3	★
3.0	D0300	15	60	3	●
3.01	D0301	17	70	4	★
3.02	D0302	17	70	4	★
3.03	D0303	17	70	4	★
3.04	D0304	17	70	4	★
3.05	D0305	17	70	4	★
3.06	D0306	17	70	4	★
3.07	D0307	17	70	4	★
3.08	D0308	17	70	4	★
3.09	D0309	17	70	4	★
3.1	D0310	17	70	4	★
3.11	D0311	17	70	4	★
3.12	D0312	17	70	4	★
3.13	D0313	17	70	4	★
3.14	D0314	17	70	4	★
3.15	D0315	17	70	4	★
3.16	D0316	17	70	4	★
3.17	D0317	17	70	4	★
3.18	D0318	17	70	4	★
3.19	D0319	17	70	4	★
3.2	D0320	17	70	4	★
3.21	D0321	17	70	4	★
3.22	D0322	17	70	4	★
3.23	D0323	17	70	4	★
3.24	D0324	17	70	4	★
3.25	D0325	17	70	4	★
3.26	D0326	17	70	4	★
3.27	D0327	17	70	4	★
3.28	D0328	17	70	4	★
3.29	D0329	17	70	4	★

Диам. сверла D1 (мм)	Обозначение	Размеры (мм)			Наличие
		L3	L1	D4	
3.3	VAPDSSUSD0330	19	70	4	★
3.31	D0331	19	70	4	★
3.32	D0332	19	70	4	★
3.33	D0333	19	70	4	★
3.34	D0334	19	70	4	★
3.35	D0335	19	70	4	★
3.36	D0336	19	70	4	★
3.37	D0337	19	70	4	★
3.38	D0338	19	70	4	★
3.39	D0339	19	70	4	★
3.4	D0340	19	70	4	★
3.41	D0341	19	70	4	★
3.42	D0342	19	70	4	★
3.43	D0343	19	70	4	★
3.44	D0344	19	70	4	★
3.45	D0345	19	70	4	★
3.46	D0346	19	70	4	★
3.47	D0347	19	70	4	★
3.48	D0348	19	70	4	★
3.49	D0349	19	70	4	★
3.5	D0350	19	70	4	●
3.51	D0351	19	70	4	★
3.52	D0352	19	70	4	★
3.53	D0353	19	70	4	★
3.54	D0354	19	70	4	★
3.55	D0355	19	70	4	★
3.56	D0356	19	70	4	★
3.57	D0357	19	70	4	★
3.58	D0358	19	70	4	★
3.59	D0359	19	70	4	★
3.6	D0360	21	70	4	★
3.61	D0361	21	70	4	★
3.62	D0362	21	70	4	★
3.63	D0363	21	70	4	★
3.64	D0364	21	70	4	★
3.65	D0365	21	70	4	★
3.66	D0366	21	70	4	★
3.67	D0367	21	70	4	★
3.68	D0368	21	70	4	★
3.69	D0369	21	70	4	★
3.7	D0370	21	70	4	★
3.71	D0371	21	70	4	★
3.72	D0372	21	70	4	★
3.73	D0373	21	70	4	★
3.74	D0374	21	70	4	★
3.75	D0375	21	70	4	★
3.76	D0376	21	70	4	★
3.77	D0377	21	70	4	★
3.78	D0378	21	70	4	★
3.79	D0379	21	70	4	★

Диам. сверла D1 (мм)	Обозначение	Размеры (мм)			Наличие
		L3	L1	D4	
3.8	VAPDSSUSD0380	21	70	4	★
3.81	D0381	21	70	4	★
3.82	D0382	21	70	4	★
3.83	D0383	21	70	4	★
3.84	D0384	21	70	4	★
3.85	D0385	21	70	4	★
3.86	D0386	21	70	4	★
3.87	D0387	21	70	4	★
3.88	D0388	21	70	4	★
3.89	D0389	21	70	4	★
3.9	D0390	21	70	4	★
3.91	D0391	21	70	4	★
3.92	D0392	21	70	4	★
3.93	D0393	21	70	4	★
3.94	D0394	21	70	4	★
3.95	D0395	21	70	4	★
3.96	D0396	21	70	4	★
3.97	D0397	21	70	4	★
3.98	D0398	21	70	4	★
3.99	D0399	21	70	4	★
4.0	D0400	21	70	4	●
4.05	D0405	21	80	6	★
4.1	D0410	21	80	6	★
4.15	D0415	21	80	6	★
4.2	D0420	21	80	6	★
4.25	D0425	21	80	6	★
4.3	D0430	23	80	6	★
4.35	D0435	23	80	6	★
4.4	D0440	23	80	6	★
4.45	D0445	23	80	6	★
4.5	D0450	23	80	6	●
4.55	D0455	23	80	6	★
4.6	D0460	25	80	6	★
4.65	D0465	25	80	6	★
4.7	D0470	25	80	6	★
4.75	D0475	25	80	6	★
4.8	D0480	25	80	6	★
4.85	D0485	25	80	6	★
4.9	D0490	25	80	6	★
4.95	D0495	25	80	6	★
5.0	D0500	25	80	6	●
5.05	D0505	25	80	6	★
5.1	D0510	25	80	6	★
5.15	D0515	25	80	6	★
5.2	D0520	25	80	6	★
5.25	D0525	25	80	6	★
5.3	D0530	25	80	6	★
5.35	D0535	27	80	6	★
5.4	D0540	27	80	6	★
5.45	D0545	27	80	6	★

● : Есть на складе. ★ : Со склада в Японии.

Диам. сверла D1 (мм)	Обозначение	Размеры (мм)			Наличие
		L3	L1	D4	
5.5	VAPDSSUSD0550	27	80	6	●
5.55	D0555	27	80	6	★
5.6	D0560	27	80	6	★
5.65	D0565	27	80	6	★
5.7	D0570	27	80	6	★
5.75	D0575	27	80	6	★
5.8	D0580	27	80	6	★
5.85	D0585	27	80	6	★
5.9	D0590	27	80	6	★
5.95	D0595	27	80	6	★
6.0	D0600	27	80	6	●
6.05	D0605	30	80	8	★
6.1	D0610	30	80	8	★
6.15	D0615	30	80	8	★
6.2	D0620	30	80	8	★
6.25	D0625	30	80	8	★
6.3	D0630	30	80	8	★
6.35	D0635	30	80	8	★
6.4	D0640	30	80	8	★
6.45	D0645	30	80	8	★
6.5	D0650	30	80	8	●
6.55	D0655	30	80	8	★
6.6	D0660	30	80	8	★
6.65	D0665	30	80	8	★
6.7	D0670	30	80	8	★
6.75	D0675	32	80	8	★
6.8	D0680	32	80	8	★
6.85	D0685	32	80	8	★
6.9	D0690	32	80	8	★
6.95	D0695	32	80	8	★
7.0	D0700	32	80	8	●
7.05	D0705	32	80	8	★
7.1	D0710	32	80	8	★
7.15	D0715	32	80	8	★
7.2	D0720	32	80	8	★
7.25	D0725	32	80	8	★
7.3	D0730	32	80	8	★
7.35	D0735	32	80	8	★
7.4	D0740	32	80	8	★
7.45	D0745	32	80	8	★
7.5	D0750	32	80	8	●
7.55	D0755	35	85	8	★
7.6	D0760	35	85	8	★
7.65	D0765	35	85	8	★
7.7	D0770	35	85	8	★
7.75	D0775	35	85	8	★
7.8	D0780	35	85	8	★
7.85	D0785	35	85	8	★
7.9	D0790	35	85	8	★
7.95	D0795	35	85	8	★

Диам. сверла D1 (мм)	Обозначение	Размеры (мм)			Наличие
		L3	L1	D4	
8.0	VAPDSSUSD0800	35	85	8	●
8.05	D0805	35	90	10	★
8.1	D0810	35	90	10	★
8.15	D0815	35	90	10	★
8.2	D0820	35	90	10	★
8.25	D0825	35	90	10	★
8.3	D0830	35	90	10	★
8.35	D0835	35	90	10	★
8.4	D0840	35	90	10	★
8.45	D0845	35	90	10	★
8.5	D0850	35	90	10	●
8.55	D0855	38	93	10	★
8.6	D0860	38	93	10	★
8.65	D0865	38	93	10	★
8.7	D0870	38	93	10	★
8.75	D0875	38	93	10	★
8.8	D0880	38	93	10	★
8.85	D0885	38	93	10	★
8.9	D0890	38	93	10	★
8.95	D0895	38	93	10	★
9.0	D0900	38	93	10	●
9.1	D0910	38	93	10	★
9.2	D0920	38	93	10	★
9.3	D0930	38	93	10	★
9.4	D0940	38	93	10	★
9.5	D0950	38	93	10	★
9.6	D0960	41	96	10	★
9.7	D0970	41	96	10	★
9.8	D0980	41	96	10	★
9.9	D0990	41	96	10	★
10.0	D1000	41	96	10	●
10.1	D1010	41	101	12	★
10.2	D1020	41	101	12	★
10.3	D1030	41	101	12	★
10.4	D1040	41	101	12	★
10.5	D1050	41	101	12	●
10.6	D1060	41	101	12	★
10.7	D1070	45	105	12	★
10.8	D1080	45	105	12	★
10.9	D1090	45	105	12	★
11.0	D1100	45	105	12	●
11.1	D1110	45	105	12	★
11.2	D1120	45	105	12	★
11.3	D1130	45	105	12	★
11.4	D1140	45	105	12	★
11.5	D1150	45	105	12	●
11.6	D1160	45	105	12	★
11.7	D1170	45	105	12	★
11.8	D1180	45	105	12	★
11.9	D1190	49	109	12	★

Диам. сверла D1 (мм)	Обозначение	Размеры (мм)			Наличие
		L3	L1	D4	
12.0	VAPDSSUSD1200	49	109	12	●
12.1	D1210	49	109	12	★
12.2	D1220	49	109	12	★
12.3	D1230	49	109	12	★
12.4	D1240	49	109	12	★
12.5	D1250	49	109	12	●
12.6	D1260	49	109	12	★
12.7	D1270	49	109	12	★
12.8	D1280	49	109	12	★
12.9	D1290	49	109	12	★
13.0	D1300	49	109	12	●
13.5	D1350	51	111	16	★
14.0	D1400	51	111	16	●
14.1	D1410	53	113	16	★
14.2	D1420	53	113	16	★
14.5	D1450	53	113	16	★
15.0	D1500	53	113	16	●
15.5	D1550	55	115	16	★
15.6	D1560	55	115	16	★
15.7	D1570	55	115	16	★
16.0	D1600	55	115	16	●
16.5	D1650	57	122	20	★
17.0	D1700	57	122	20	★
17.5	D1750	58	123	20	★
17.6	D1760	58	123	20	★
17.7	D1770	58	123	20	★
18.0	D1800	58	123	20	★
18.5	D1850	60	125	20	★
19.0	D1900	60	125	20	★
19.5	D1950	62	127	20	★
19.6	D1960	62	127	20	★
19.7	D1970	62	127	20	★
20.0	D2000	62	127	20	★

# VAPDMSUS

Средняя длина рабочей части, высокая точность, для обработки нержавеющей стали



Быстрорежущая  
сталь

Углеродистая сталь Легированная сталь	Закалённая сталь	Нержавеющая сталь	Чугун	Лёгкий сплав	Жаропрочные сплавы
○		◎	○	○	

$0.5 \leq D_1 \leq 3$	$3 < D_1 \leq 6$	$6 < D_1 \leq 10$	$10 < D_1 \leq 13$
$0$ -0.014	$0$ -0.018	$0$ -0.022	$0$ -0.027

\* Все сверла за исключением сверл с диаметром кратным 0.1 мм и диаметром свыше 4.0 мм имеют допуск 0--0.009 мм.

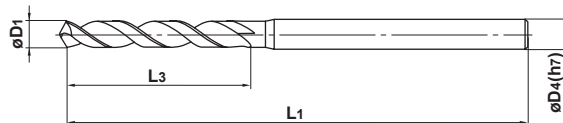

● Сочетание новой геометрии и покрытия Violet обеспечивает эффективное сверление и высокую стойкость при обработке нержавеющих сталей.

Диам. сверла D1 (мм)	Обозначение	Размеры (мм)			Наличие
		L3	L1	D4	
0.5	VAPDMSUSD0050	6	50	3	●
0.51	D0051	6	50	3	★
0.52	D0052	6	50	3	★
0.53	D0053	6	50	3	★
0.54	D0054	6	50	3	★
0.55	D0055	6	50	3	★
0.56	D0056	8	50	3	★
0.57	D0057	8	50	3	★
0.58	D0058	8	50	3	★
0.59	D0059	8	50	3	★
0.6	D0060	8	50	3	★
0.61	D0061	8	50	3	★
0.62	D0062	8	50	3	★
0.63	D0063	8	50	3	★
0.64	D0064	8	50	3	★
0.65	D0065	8	50	3	★
0.66	D0066	8	50	3	★
0.67	D0067	8	50	3	★
0.68	D0068	8	50	3	★
0.69	D0069	8	50	3	★
0.7	D0070	10	50	3	★
0.71	D0071	10	50	3	★
0.72	D0072	10	50	3	★
0.73	D0073	10	50	3	★
0.74	D0074	10	50	3	★
0.75	D0075	10	50	3	★
0.76	D0076	10	50	3	★
0.77	D0077	10	50	3	★
0.78	D0078	10	50	3	★
0.79	D0079	10	50	3	★
0.8	D0080	10	50	3	★
0.81	D0081	10	50	3	★
0.82	D0082	10	50	3	★
0.83	D0083	10	50	3	★
0.84	D0084	10	50	3	★
0.85	D0085	10	50	3	★
0.86	D0086	12	50	3	★
0.87	D0087	12	50	3	★
0.88	D0088	12	50	3	★
0.89	D0089	12	50	3	★

Диам. сверла D1 (мм)	Обозначение	Размеры (мм)			Наличие
		L3	L1	D4	
0.9	VAPDMSUSD0090	12	50	3	★
0.91	D0091	12	50	3	★
0.92	D0092	12	50	3	★
0.93	D0093	12	50	3	★
0.94	D0094	12	50	3	★
0.95	D0095	12	50	3	★
0.96	D0096	12	50	3	★
0.97	D0097	12	50	3	★
0.98	D0098	12	50	3	★
0.99	D0099	12	50	3	★
1.0	D0100	12	60	3	●
1.01	D0101	12	60	3	★
1.02	D0102	12	60	3	★
1.03	D0103	12	60	3	★
1.04	D0104	12	60	3	★
1.05	D0105	12	60	3	★
1.06	D0106	12	60	3	★
1.07	D0107	16	60	3	★
1.08	D0108	16	60	3	★
1.09	D0109	16	60	3	★
1.1	D0110	16	60	3	★
1.11	D0111	16	60	3	★
1.12	D0112	16	60	3	★
1.13	D0113	16	60	3	★
1.14	D0114	16	60	3	★
1.15	D0115	16	60	3	★
1.16	D0116	16	60	3	★
1.17	D0117	16	60	3	★
1.18	D0118	16	60	3	★
1.19	D0119	16	60	3	★
1.2	D0120	16	60	3	★
1.21	D0121	16	60	3	★
1.22	D0122	16	60	3	★
1.23	D0123	16	60	3	★
1.24	D0124	16	60	3	★
1.25	D0125	16	60	3	★
1.26	D0126	16	60	3	★
1.27	D0127	16	60	3	★
1.28	D0128	16	60	3	★
1.29	D0129	16	60	3	★

СВЕРЛЕНИЕ

Диам. сверла D1 (мм)	Обозначение	Размеры (мм)			Наличие
		L3	L1	D4	
1.3	VAPDMSUSD0130	16	60	3	★
1.31	D0131	18	60	3	★
1.32	D0132	18	60	3	★
1.33	D0133	18	60	3	★
1.34	D0134	18	60	3	★
1.35	D0135	18	60	3	★
1.36	D0136	18	60	3	★
1.37	D0137	18	60	3	★
1.38	D0138	18	60	3	★
1.39	D0139	18	60	3	★
1.4	D0140	18	60	3	★
1.41	D0141	18	60	3	★
1.42	D0142	18	60	3	★
1.43	D0143	18	60	3	★
1.44	D0144	18	60	3	★
1.45	D0145	18	60	3	★
1.46	D0146	18	60	3	★
1.47	D0147	18	60	3	★
1.48	D0148	18	60	3	★
1.49	D0149	18	60	3	★
1.5	D0150	18	60	3	●
1.51	D0151	20	60	3	★
1.52	D0152	20	60	3	★
1.53	D0153	20	60	3	★
1.54	D0154	20	60	3	★
1.55	D0155	20	60	3	★
1.56	D0156	20	60	3	★
1.57	D0157	20	60	3	★
1.58	D0158	20	60	3	★
1.59	D0159	20	60	3	★
1.6	D0160	20	60	3	★
1.61	D0161	20	60	3	★
1.62	D0162	20	60	3	★
1.63	D0163	20	60	3	★
1.64	D0164	20	60	3	★
1.65	D0165	20	60	3	★
1.66	D0166	20	60	3	★
1.67	D0167	20	60	3	★
1.68	D0168	20	60	3	★
1.69	D0169	20	60	3	★
1.7	D0170	20	60	3	★
1.71	D0171	20	60	3	★
1.72	D0172	20	60	3	★
1.73	D0173	20	60	3	★
1.74	D0174	20	60	3	★
1.75	D0175	20	60	3	★
1.76	D0176	20	60	3	★
1.77	D0177	20	60	3	★
1.78	D0178	20	60	3	★
1.79	D0179	20	60	3	★

Диам. сверла D1 (мм)	Обозначение	Размеры (мм)			Наличие
		L3	L1	D4	
1.8	VAPDMSUSD0180	22	60	3	★
1.81	D0181	22	60	3	★
1.82	D0182	22	60	3	★
1.83	D0183	22	60	3	★
1.84	D0184	22	60	3	★
1.85	D0185	22	60	3	★
1.86	D0186	22	60	3	★
1.87	D0187	22	60	3	★
1.88	D0188	22	60	3	★
1.89	D0189	22	60	3	★
1.9	D0190	22	60	3	★
1.91	D0191	23	60	3	★
1.92	D0192	23	60	3	★
1.93	D0193	23	60	3	★
1.94	D0194	23	60	3	★
1.95	D0195	23	60	3	★
1.96	D0196	23	60	3	★
1.97	D0197	23	60	3	★
1.98	D0198	23	60	3	★
1.99	D0199	23	60	3	★
2.0	D0200	23	70	3	●
2.01	D0201	23	70	3	★
2.02	D0202	23	70	3	★
2.03	D0203	23	70	3	★
2.04	D0204	23	70	3	★
2.05	D0205	23	70	3	★
2.06	D0206	23	70	3	★
2.07	D0207	23	70	3	★
2.08	D0208	23	70	3	★
2.09	D0209	23	70	3	★
2.1	D0210	23	70	3	★
2.11	D0211	23	70	3	★
2.12	D0212	23	70	3	★
2.13	D0213	23	70	3	★
2.14	D0214	23	70	3	★
2.15	D0215	23	70	3	★
2.16	D0216	23	70	3	★
2.17	D0217	23	70	3	★
2.18	D0218	23	70	3	★
2.19	D0219	23	70	3	★
2.2	D0220	26	70	3	★
2.21	D0221	26	70	3	★
2.22	D0222	26	70	3	★
2.23	D0223	26	70	3	★
2.24	D0224	26	70	3	★
2.25	D0225	26	70	3	★
2.26	D0226	26	70	3	★
2.27	D0227	26	70	3	★
2.28	D0228	26	70	3	★
2.29	D0229	26	70	3	★

● : Есть на складе. ★ : Со склада в Японии.

Диам. сверла D1 (мм)	Обозначение	Размеры (мм)			Наличие	Диам. сверла D1 (мм)	Обозначение	Размеры (мм)			Наличие
		L3	L1	D4				L3	L1	D4	
2.3	VAPDMSUSD0230	26	70	3	★	2.8	VAPDMSUSD0280	32	70	3	★
2.31	D0231	26	70	3	★	2.81	D0281	32	70	3	★
2.32	D0232	26	70	3	★	2.82	D0282	32	70	3	★
2.33	D0233	26	70	3	★	2.83	D0283	32	70	3	★
2.34	D0234	26	70	3	★	2.84	D0284	32	70	3	★
2.35	D0235	26	70	3	★	2.85	D0285	32	70	3	★
2.36	D0236	26	70	3	★	2.86	D0286	32	70	3	★
2.37	D0237	26	70	3	★	2.87	D0287	32	70	3	★
2.38	D0238	26	70	3	★	2.88	D0288	32	70	3	★
2.39	D0239	26	70	3	★	2.89	D0289	32	70	3	★
2.4	D0240	29	70	3	★	2.9	D0290	32	70	3	★
2.41	D0241	29	70	3	★	2.91	D0291	32	70	3	★
2.42	D0242	29	70	3	★	2.92	D0292	32	70	3	★
2.43	D0243	29	70	3	★	2.93	D0293	32	70	3	★
2.44	D0244	29	70	3	★	2.94	D0294	32	70	3	★
2.45	D0245	29	70	3	★	2.95	D0295	32	70	3	★
2.46	D0246	29	70	3	★	2.96	D0296	32	70	3	★
2.47	D0247	29	70	3	★	2.97	D0297	32	70	3	★
2.48	D0248	29	70	3	★	2.98	D0298	32	70	3	★
2.49	D0249	29	70	3	★	2.99	D0299	32	70	3	★
2.5	D0250	29	70	3	●	3.0	D0300	32	70	3	●
2.51	D0251	29	70	3	★	3.01	D0301	35	85	4	★
2.52	D0252	29	70	3	★	3.02	D0302	35	85	4	★
2.53	D0253	29	70	3	★	3.03	D0303	35	85	4	★
2.54	D0254	29	70	3	★	3.04	D0304	35	85	4	★
2.55	D0255	29	70	3	★	3.05	D0305	35	85	4	★
2.56	D0256	29	70	3	★	3.06	D0306	35	85	4	★
2.57	D0257	29	70	3	★	3.07	D0307	35	85	4	★
2.58	D0258	29	70	3	★	3.08	D0308	35	85	4	★
2.59	D0259	29	70	3	★	3.09	D0309	35	85	4	★
2.6	D0260	29	70	3	★	3.1	D0310	35	85	4	★
2.61	D0261	29	70	3	★	3.11	D0311	35	85	4	★
2.62	D0262	29	70	3	★	3.12	D0312	35	85	4	★
2.63	D0263	29	70	3	★	3.13	D0313	35	85	4	★
2.64	D0264	29	70	3	★	3.14	D0314	35	85	4	★
2.65	D0265	29	70	3	★	3.15	D0315	35	85	4	★
2.66	D0266	29	70	3	★	3.16	D0316	35	85	4	★
2.67	D0267	29	70	3	★	3.17	D0317	35	85	4	★
2.68	D0268	29	70	3	★	3.18	D0318	35	85	4	★
2.69	D0269	29	70	3	★	3.19	D0319	35	85	4	★
2.7	D0270	32	70	3	★	3.2	D0320	35	85	4	★
2.71	D0271	32	70	3	★	3.21	D0321	35	85	4	★
2.72	D0272	32	70	3	★	3.22	D0322	35	85	4	★
2.73	D0273	32	70	3	★	3.23	D0323	35	85	4	★
2.74	D0274	32	70	3	★	3.24	D0324	35	85	4	★
2.75	D0275	32	70	3	★	3.25	D0325	35	85	4	★
2.76	D0276	32	70	3	★	3.26	D0326	35	85	4	★
2.77	D0277	32	70	3	★	3.27	D0327	35	85	4	★
2.78	D0278	32	70	3	★	3.28	D0328	35	85	4	★
2.79	D0279	32	70	3	★	3.29	D0329	35	85	4	★

Диам. сверла D1 (мм)	Обозначение	Размеры (мм)			Наличие
		L3	L1	D4	
3.3	VAPDMSUSD0330	35	85	4	★
3.31	D0331	38	85	4	★
3.32	D0332	38	85	4	★
3.33	D0333	38	85	4	★
3.34	D0334	38	85	4	★
3.35	D0335	38	85	4	★
3.36	D0336	38	85	4	★
3.37	D0337	38	85	4	★
3.38	D0338	38	85	4	★
3.39	D0339	38	85	4	★
3.4	D0340	38	85	4	★
3.41	D0341	38	85	4	★
3.42	D0342	38	85	4	★
3.43	D0343	38	85	4	★
3.44	D0344	38	85	4	★
3.45	D0345	38	85	4	★
3.46	D0346	38	85	4	★
3.47	D0347	38	85	4	★
3.48	D0348	38	85	4	★
3.49	D0349	38	85	4	★
3.5	D0350	38	85	4	●
3.51	D0351	38	85	4	★
3.52	D0352	38	85	4	★
3.53	D0353	38	85	4	★
3.54	D0354	38	85	4	★
3.55	D0355	38	85	4	★
3.56	D0356	38	85	4	★
3.57	D0357	38	85	4	★
3.58	D0358	38	85	4	★
3.59	D0359	38	85	4	★
3.6	D0360	38	85	4	★
3.61	D0361	38	85	4	★
3.62	D0362	38	85	4	★
3.63	D0363	38	85	4	★
3.64	D0364	38	85	4	★
3.65	D0365	38	85	4	★
3.66	D0366	38	85	4	★
3.67	D0367	38	85	4	★
3.68	D0368	38	85	4	★
3.69	D0369	38	85	4	★
3.7	D0370	38	85	4	★
3.71	D0371	42	85	4	★
3.72	D0372	42	85	4	★
3.73	D0373	42	85	4	★
3.74	D0374	42	85	4	★
3.75	D0375	42	85	4	★
3.76	D0376	42	85	4	★
3.77	D0377	42	85	4	★
3.78	D0378	42	85	4	★
3.79	D0379	42	85	4	★

Диам. сверла D1 (мм)	Обозначение	Размеры (мм)			Наличие
		L3	L1	D4	
3.8	VAPDMSUSD0380	42	85	4	★
3.81	D0381	42	85	4	★
3.82	D0382	42	85	4	★
3.83	D0383	42	85	4	★
3.84	D0384	42	85	4	★
3.85	D0385	42	85	4	★
3.86	D0386	42	85	4	★
3.87	D0387	42	85	4	★
3.88	D0388	42	85	4	★
3.89	D0389	42	85	4	★
3.9	D0390	42	85	4	★
3.91	D0391	42	85	4	★
3.92	D0392	42	85	4	★
3.93	D0393	42	85	4	★
3.94	D0394	42	85	4	★
3.95	D0395	42	85	4	★
3.96	D0396	42	85	4	★
3.97	D0397	42	85	4	★
3.98	D0398	42	85	4	★
3.99	D0399	42	85	4	★
4.0	D0400	42	85	4	●
4.05	D0405	42	100	6	★
4.1	D0410	42	100	6	★
4.15	D0415	42	100	6	★
4.2	D0420	42	100	6	★
4.25	D0425	46	100	6	★
4.3	D0430	46	100	6	★
4.35	D0435	46	100	6	★
4.4	D0440	46	100	6	★
4.45	D0445	46	100	6	★
4.5	D0450	46	100	6	●
4.55	D0455	46	100	6	★
4.6	D0460	46	100	6	★
4.65	D0465	46	100	6	★
4.7	D0470	46	100	6	★
4.75	D0475	46	100	6	★
4.8	D0480	51	100	6	★
4.85	D0485	51	100	6	★
4.9	D0490	51	100	6	★
4.95	D0495	51	100	6	★
5.0	D0500	51	100	6	●
5.05	D0505	51	100	6	★
5.1	D0510	51	100	6	★
5.15	D0515	51	100	6	★
5.2	D0520	51	100	6	★
5.25	D0525	51	100	6	★
5.3	D0530	51	100	6	★
5.35	D0535	56	106	6	★
5.4	D0540	56	106	6	★
5.45	D0545	56	106	6	★

● : Есть на складе. ★ : Со склада в Японии.

Диам. сверла D1 (мм)	Обозначение	Размеры (мм)			Наличие
		L3	L1	D4	
5.5	VAPDMSUSD0550	56	106	6	●
5.55	D0555	56	106	6	★
5.6	D0560	56	106	6	★
5.65	D0565	56	106	6	★
5.7	D0570	56	106	6	★
5.75	D0575	56	106	6	★
5.8	D0580	56	106	6	★
5.85	D0585	56	106	6	★
5.9	D0590	56	106	6	★
5.95	D0595	56	106	6	★
6.0	D0600	56	106	6	●
6.05	D0605	62	112	8	★
6.1	D0610	62	112	8	★
6.15	D0615	62	112	8	★
6.2	D0620	62	112	8	★
6.25	D0625	62	112	8	★
6.3	D0630	62	112	8	★
6.35	D0635	62	112	8	★
6.4	D0640	62	112	8	★
6.45	D0645	62	112	8	★
6.5	D0650	62	112	8	●
6.55	D0655	62	112	8	★
6.6	D0660	62	112	8	★
6.65	D0665	62	112	8	★
6.7	D0670	62	112	8	★
6.75	D0675	67	117	8	★
6.8	D0680	67	117	8	★
6.85	D0685	67	117	8	★
6.9	D0690	67	117	8	★
6.95	D0695	67	117	8	★
7.0	D0700	67	117	8	●
7.05	D0705	67	117	8	★
7.1	D0710	67	117	8	★
7.15	D0715	67	117	8	★
7.2	D0720	67	117	8	★
7.25	D0725	67	117	8	★
7.3	D0730	67	117	8	★
7.35	D0735	67	117	8	★
7.4	D0740	67	117	8	★
7.45	D0745	67	117	8	★
7.5	D0750	67	117	8	●
7.55	D0755	73	123	8	★
7.6	D0760	73	123	8	★
7.65	D0765	73	123	8	★
7.7	D0770	73	123	8	★
7.75	D0775	73	123	8	★
7.8	D0780	73	123	8	★
7.85	D0785	73	123	8	★
7.9	D0790	73	123	8	★
7.95	D0795	73	123	8	★

Диам. сверла D1 (мм)	Обозначение	Размеры (мм)			Наличие
		L3	L1	D4	
8.0	VAPDMSUSD0800	73	123	8	●
8.05	D0805	73	128	10	★
8.1	D0810	73	128	10	★
8.15	D0815	73	128	10	★
8.2	D0820	73	128	10	★
8.25	D0825	73	128	10	★
8.3	D0830	73	128	10	★
8.35	D0835	73	128	10	★
8.4	D0840	73	128	10	★
8.45	D0845	73	128	10	★
8.5	D0850	73	128	10	●
8.55	D0855	79	134	10	★
8.6	D0860	79	134	10	★
8.65	D0865	79	134	10	★
8.7	D0870	79	134	10	★
8.75	D0875	79	134	10	★
8.8	D0880	79	134	10	★
8.85	D0885	79	134	10	★
8.9	D0890	79	134	10	★
8.95	D0895	79	134	10	★
9.0	D0900	79	134	10	●
9.1	D0910	79	134	10	★
9.2	D0920	79	134	10	★
9.3	D0930	79	134	10	★
9.4	D0940	79	134	10	★
9.5	D0950	79	134	10	★
9.6	D0960	85	140	10	★
9.7	D0970	85	140	10	★
9.8	D0980	85	140	10	★
9.9	D0990	85	140	10	★
10.0	D1000	85	140	10	●
10.1	D1010	85	145	12	★
10.2	D1020	85	145	12	★
10.3	D1030	85	145	12	★
10.4	D1040	85	145	12	★
10.5	D1050	85	145	12	●
10.6	D1060	85	145	12	★
10.7	D1070	92	152	12	★
10.8	D1080	92	152	12	★
10.9	D1090	92	152	12	★
11.0	D1100	92	152	12	●
11.1	D1110	92	152	12	★
11.2	D1120	92	152	12	★
11.3	D1130	92	152	12	★
11.4	D1140	92	152	12	★
11.5	D1150	92	152	12	★
11.6	D1160	92	152	12	★
11.7	D1170	92	152	12	★
11.8	D1180	92	152	12	★
11.9	D1190	99	159	12	★

Диам. сверла D1 (мм)	Обозначение	Размеры (мм)			Наличие
		L3	L1	D4	
12.0	<b>VAPDMSUSD1200</b>	99	159	12	●
12.1	<b>D1210</b>	99	159	12	★
12.2	<b>D1220</b>	99	159	12	★
12.3	<b>D1230</b>	99	159	12	★
12.4	<b>D1240</b>	99	159	12	★
12.5	<b>D1250</b>	99	159	12	●
12.6	<b>D1260</b>	99	159	12	★
12.7	<b>D1270</b>	99	159	12	★
12.8	<b>D1280</b>	99	159	12	★
12.9	<b>D1290</b>	99	159	12	★
13.0	<b>D1300</b>	99	159	12	★

## РЕКОМЕНДУЕМЫЕ РЕЖИМЫ РЕЗАНИЯ

Обрабатываемый материал	Нержавеющая сталь				Углеродистая сталь Cf53, Легированная сталь 070M55, Чугун, Медь, Медный сплав	Конструкционная сталь, Алюминиевые сплавы		
	Аустенитная X5CrNi1810 X5CrNiMo17122		Мартенситные, Ферритные X10CrAl18					
Диам. сверла (мм)	Частота вращения (мин <sup>-1</sup> )	Подача (мм/об)	Частота вращения (мин <sup>-1</sup> )	Подача (мм/об)	Частота вращения (мин <sup>-1</sup> )	Подача (мм/об)	Частота вращения (мин <sup>-1</sup> )	Подача (мм/об)
<b>0.5</b>	7600	0.01	8800	0.01	11250	0.01	15000	0.02
<b>1.0</b>	4800	0.02	6300	0.05	10000	0.05	12000	0.05
<b>2.0</b>	2400	0.04	3200	0.06	5500	0.09	6400	0.09
<b>3.0</b>	1600	0.07	2100	0.10	3700	0.13	4300	0.13
<b>4.0</b>	1200	0.09	1600	0.10	2800	0.15	3200	0.15
<b>5.0</b>	950	0.12	1300	0.13	2200	0.18	2600	0.18
<b>6.0</b>	800	0.14	1100	0.15	1800	0.20	2100	0.19
<b>8.0</b>	600	0.18	800	0.18	1400	0.22	1600	0.24
<b>10.0</b>	480	0.22	640	0.21	1100	0.25	1300	0.28
<b>12.0</b>	400	0.24	530	0.25	930	0.30	1100	0.34
<b>13.0</b>	370	0.26	490	0.28	860	0.32	1000	0.36
<b>14.0</b>	340	0.30	450	0.27	730	0.31	930	0.36
<b>15.0</b>	320	0.31	425	0.28	680	0.32	870	0.38
<b>16.0</b>	300	0.32	400	0.30	640	0.34	820	0.42
<b>18.0</b>	270	0.34	350	0.32	570	0.36	725	0.43
<b>20.0</b>	240	0.36	320	0.35	510	0.38	660	0.45

- 1) Пожалуйста, снизьте обороты и подачу при недостаточной жесткости закрепленной детали или ограничениях станка.
- 2) Пожалуйста, используйте сверлильную оправку цангового типа.
- 3) Используйте достаточное количество СОЖ.
- 4) Не используйте ступенчатое сверление и снизьте режимы резания при сверлении отверстий, глубина которых превышает 3×D (D - диаметр сверла).

Вышеупомянутые режимы резания указаны для обработки с СОЖ.  
Пожалуйста, снизьте обороты при обработке без СОЖ.

# VIOLET СВЕРЛА

## VSD

### Цилиндрический хвостовик



Заострение

Заострение

$D_1 < 0.7$

$D_1 \geq 0.7$

$D_1 < 2$

$D_1 \geq 2$

Углеродистая сталь Легированная сталь	Закалённая сталь	Нержавеющая сталь	Чугун	Лёгкий сплав	Жаропрочные сплавы
◎		○	○		

$0.5 \leq D_1 \leq 1$	$1 \leq D_1 \leq 3$	$3 < D_1 \leq 6$	$6 < D_1 \leq 10$	$10 < D_1 \leq 13$
$0$ $-0.010$	$0$ $-0.014$	$0$ $-0.018$	$0$ $-0.022$	$0$ $-0.027$

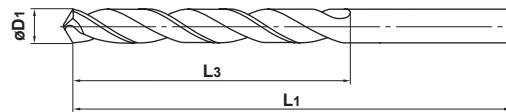

Диам. сверла D1 (мм)	Обозначение	Размеры (мм)		Наличие
		L3	L1	
0.5	VSDD0050	6	27	★
0.6	D0060	7	30	●
0.7	D0070	9	32	●
0.8	D0080	10	34	●
0.9	D0090	11	36	●
1.0	D0100	12	40	●
1.1	D0110	14	42	●
1.2	D0120	16	42	●
1.3	D0130	16	45	●
1.4	D0140	18	48	●
1.5	D0150	18	48	●
1.6	D0160	20	50	●
1.7	D0170	20	50	★
1.8	D0180	22	52	●
1.9	D0190	22	52	●
2.0	D0200	23	55	●
2.1	D0210	23	55	●
2.2	D0220	26	58	●
2.3	D0230	26	58	★
2.4	D0240	29	61	★
2.5	D0250	29	61	●
2.6	D0260	29	64	★
2.7	D0270	32	64	★
2.8	D0280	32	67	●
2.9	D0290	32	71	★
3.0	D0300	32	71	●
3.1	D0310	35	71	●
3.2	D0320	35	71	●
3.3	D0330	35	73	●
3.4	D0340	38	73	●
3.5	D0350	38	73	●
3.6	D0360	38	76	★
3.7	D0370	38	76	★
3.8	D0380	42	76	★
3.9	D0390	42	79	★
4.0	D0400	42	83	●
4.1	D0410	42	83	●
4.2	D0420	42	83	●
4.3	D0430	46	83	●
4.4	D0440	46	86	★

Диам. сверла D1 (мм)	Обозначение	Размеры (мм)		Наличие
		L3	L1	
4.5	VSDD0450	46	86	●
4.6	D0460	46	86	★
4.7	D0470	46	89	★
4.8	D0480	51	89	●
4.9	D0490	51	92	★
5.0	D0500	51	92	●
5.1	D0510	51	92	●
5.2	D0520	51	95	●
5.3	D0530	51	95	★
5.4	D0540	56	95	★
5.5	D0550	56	95	●
5.6	D0560	56	98	★
5.7	D0570	56	98	★
5.8	D0580	56	98	★
5.9	D0590	56	98	●
6.0	D0600	56	102	●
6.1	D0610	62	102	★
6.2	D0620	62	102	●
6.3	D0630	62	102	●
6.4	D0640	62	105	★
6.5	D0650	62	105	●
6.6	D0660	62	105	★
6.7	D0670	62	105	★
6.8	D0680	67	105	●
6.9	D0690	67	105	★
7.0	D0700	67	105	●
7.1	D0710	67	108	★
7.2	D0720	67	108	★
7.3	D0730	67	108	●
7.4	D0740	67	111	★
7.5	D0750	67	111	★
7.6	D0760	73	111	★
7.7	D0770	73	114	★
7.8	D0780	73	114	★
7.9	D0790	73	114	●
8.0	D0800	73	114	●
8.1	D0810	73	117	★
8.2	D0820	73	117	★
8.3	D0830	73	117	★
8.4	D0840	73	121	★

● : Есть на складе. ★ : Со склада в Японии.

Диам. сверла D1 (мм)	Обозначение	Размеры (мм)		Наличие	Диам. сверла D1 (мм)	Обозначение	Размеры (мм)		Наличие
		L3	L1				L3	L1	
8.5	VSDD0850	73	121	●	10.8	VSDD1080	92	140	★
8.6	D0860	79	121	●	10.9	D1090	92	140	★
8.7	D0870	79	121	●	11.0	D1100	92	140	●
8.8	D0880	79	124	★	11.1	D1110	92	140	★
8.9	D0890	79	124	★	11.2	D1120	92	143	★
9.0	D0900	79	124	●	11.3	D1130	92	143	★
9.1	D0910	79	124	★	11.4	D1140	92	143	★
9.2	D0920	79	127	★	11.5	D1150	92	143	★
9.3	D0930	79	127	★	11.6	D1160	92	146	★
9.4	D0940	79	127	★	11.7	D1170	92	146	★
9.5	D0950	79	127	●	11.8	D1180	92	146	★
9.6	D0960	85	130	★	11.9	D1190	99	146	★
9.7	D0970	85	130	★	12.0	D1200	99	149	●
9.8	D0980	85	130	★	12.1	D1210	99	149	★
9.9	D0990	85	130	★	12.2	D1220	99	149	★
10.0	D1000	85	130	●	12.3	D1230	99	149	★
10.1	D1010	85	133	★	12.4	D1240	99	152	★
10.2	D1020	85	133	●	12.5	D1250	99	152	★
10.3	D1030	85	133	●	12.6	D1260	99	152	★
10.4	D1040	85	133	★	12.7	D1270	99	152	★
10.5	D1050	85	137	●	12.8	D1280	99	152	★
10.6	D1060	85	137	★	12.9	D1290	99	152	★
10.7	D1070	92	137	★	13.0	D1300	99	152	●

## РЕКОМЕНДУЕМЫЕ РЕЖИМЫ РЕЗАНИЯ

Обрабатываемый материал	Конструкционная сталь		Углеродистая сталь Ck55		Нержавеющая сталь X20Cr13		Нержавеющая сталь X5CrNi1810 Инструментальная сталь X210Cr12 (Материалы низкой твердости) Термообработанные стали X40CrMoV51 (-40HRC)	
	40м/мин		30м/мин		20м/мин		10—14м/мин	
Скорость резания	40м/мин		30м/мин		20м/мин		10—14м/мин	
Диам. сверла (мм)	Частота вращения (мин <sup>-1</sup> )	Подача (мм/об)	Частота вращения (мин <sup>-1</sup> )	Подача (мм/об)	Частота вращения (мин <sup>-1</sup> )	Подача (мм/об)	Частота вращения (мин <sup>-1</sup> )	Подача (мм/об)
0.5	15000	0.01	11250	0.01	7500	0.01	5620	0.01
1.0	10000	0.02	7500	0.02	5000	0.02	3750	0.02
1.5	8200	0.03	6150	0.03	4100	0.03	2800	0.03
2.0	6370	0.05	4780	0.05	3180	0.05	2200	0.04
3.0	4250	0.10	3180	0.10	2120	0.07	1400	0.06
4.0	3180	0.13	2390	0.13	1590	0.09	1100	0.08
5.0	2550	0.15	1910	0.15	1270	0.11	860	0.10
6.0	2120	0.18	1590	0.18	1060	0.13	720	0.11
7.0	1820	0.20	1360	0.20	910	0.14	610	0.12
8.0	1590	0.22	1190	0.21	800	0.15	540	0.13
9.0	1420	0.24	1060	0.22	710	0.17	480	0.14
10.0	1270	0.26	960	0.23	640	0.18	430	0.15
11.0	1160	0.28	870	0.24	580	0.19	390	0.16
12.0	1060	0.30	800	0.25	530	0.20	360	0.17
13.0	980	0.30	730	0.26	490	0.20	330	0.17

- 1) Пожалуйста, снизьте обороты при недостаточной жесткости закрепленной детали.
- 2) Не используйте ступенчатое сверление и снизьте режимы резания при сверлении отверстий, глубина которых превышает 3×D (D - диаметр сверла).
- 3) Вышеупомянутые режимы резания указаны для обработки с СОЖ.  
Пожалуйста, снизьте обороты при обработке без СОЖ.

# VIOLET СВЕРЛА

## VAPDSCB

Короткая длина рабочей части, высокая точность, подходит для рассверливания



Быстроотверждающаяся сталь

Углеродистая сталь Легированная сталь	Закалённая сталь	Нержавеющая сталь	Чугун	Лёгкий сплав	Жаропрочные сплавы
◎		○	○	○	

D1 ≤ 3	3 < D1 ≤ 6	6 < D1 ≤ 10	10 < D1 ≤ 18	18 < D1 ≤ 30	30 < D1 ≤ 32
0 -0.014	0 -0.018	0 -0.022	0 -0.027	0 -0.033	0 -0.039

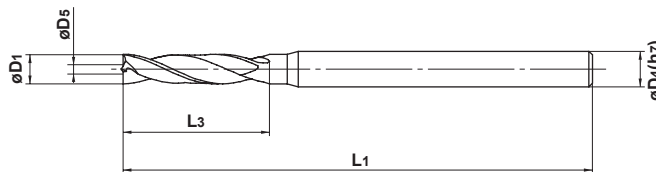

- Уникальная геометрия для высокоэффективного рассверливания. Хорошее стружкодробление и качество поверхности после рассверливания.

Диам. сверла D1 (мм)	Обозначение	Размеры (мм)				Наличие
		D5	L3	L1	D4	
2.0	<b>VAPDSCBD0200</b>	0.7	12	60	3	★
2.1	<b>D0210</b>	0.7	12	60	3	★
2.2	<b>D0220</b>	0.7	12	60	3	★
2.3	<b>D0230</b>	0.7	13	60	3	★
2.4	<b>D0240</b>	0.7	13	60	3	★
2.5	<b>D0250</b>	0.7	13	60	3	★
2.6	<b>D0260</b>	0.8	15	60	3	★
2.7	<b>D0270</b>	0.8	15	60	3	★
2.8	<b>D0280</b>	0.8	15	60	3	★
2.9	<b>D0290</b>	0.8	15	60	3	★
3.0	<b>D0300</b>	0.8	15	60	3	★
3.1	<b>D0310</b>	0.8	17	70	4	★
3.2	<b>D0320</b>	0.8	17	70	4	★
3.3	<b>D0330</b>	0.8	19	70	4	★
3.4	<b>D0340</b>	0.8	19	70	4	★
3.5	<b>D0350</b>	0.8	19	70	4	★
3.6	<b>D0360</b>	1.0	21	70	4	★
3.7	<b>D0370</b>	1.0	21	70	4	★
3.8	<b>D0380</b>	1.0	21	70	4	★
3.9	<b>D0390</b>	1.0	21	70	4	★
4.0	<b>D0400</b>	1.0	21	70	4	★
4.1	<b>D0410</b>	1.0	21	80	6	★
4.2	<b>D0420</b>	1.0	21	80	6	★
4.3	<b>D0430</b>	1.0	23	80	6	★
4.4	<b>D0440</b>	1.0	23	80	6	★
4.5	<b>D0450</b>	1.0	23	80	6	★
4.6	<b>D0460</b>	1.4	25	80	6	★
4.7	<b>D0470</b>	1.4	25	80	6	★
4.8	<b>D0480</b>	1.4	25	80	6	★
4.9	<b>D0490</b>	1.4	25	80	6	★
5.0	<b>D0500</b>	1.4	25	80	6	★
5.1	<b>D0510</b>	1.4	25	80	6	★
5.2	<b>D0520</b>	1.4	25	80	6	★
5.3	<b>D0530</b>	1.4	25	80	6	★
5.4	<b>D0540</b>	1.4	27	80	6	★
5.5	<b>D0550</b>	1.4	27	80	6	★
5.6	<b>D0560</b>	1.4	27	80	6	★
5.7	<b>D0570</b>	1.4	27	80	6	★
5.8	<b>D0580</b>	1.4	27	80	6	★
5.9	<b>D0590</b>	1.4	27	80	6	★

Диам. сверла D1 (мм)	Обозначение	Размеры (мм)				Наличие
		D5	L3	L1	D4	
6.0	<b>VAPDSCBD0600</b>	1.4	27	80	6	★
6.1	<b>D0610</b>	1.4	30	80	8	★
6.2	<b>D0620</b>	1.4	30	80	8	★
6.3	<b>D0630</b>	1.4	30	80	8	★
6.4	<b>D0640</b>	1.4	30	80	8	★
6.5	<b>D0650</b>	1.4	30	80	8	★
6.6	<b>D0660</b>	1.8	30	80	8	★
6.7	<b>D0670</b>	1.8	30	80	8	★
6.8	<b>D0680</b>	1.8	32	80	8	★
6.9	<b>D0690</b>	1.8	32	80	8	★
7.0	<b>D0700</b>	1.8	32	80	8	★
7.1	<b>D0710</b>	1.8	32	80	8	★
7.2	<b>D0720</b>	1.8	32	80	8	★
7.3	<b>D0730</b>	1.8	32	80	8	★
7.4	<b>D0740</b>	1.8	32	80	8	★
7.5	<b>D0750</b>	1.8	32	80	8	★
7.6	<b>D0760</b>	2.0	35	85	8	★
7.7	<b>D0770</b>	2.0	35	85	8	★
7.8	<b>D0780</b>	2.0	35	85	8	★
7.9	<b>D0790</b>	2.0	35	85	8	★
8.0	<b>D0800</b>	2.0	35	85	8	★
8.1	<b>D0810</b>	2.0	35	90	10	★
8.5	<b>D0850</b>	2.0	35	90	10	★
8.6	<b>D0860</b>	2.8	38	93	10	★
8.8	<b>D0880</b>	2.8	38	93	10	★
9.0	<b>D0900</b>	2.8	38	93	10	★
9.1	<b>D0910</b>	2.8	38	93	10	★
9.5	<b>D0950</b>	2.8	38	93	10	★
9.6	<b>D0960</b>	3.2	41	96	10	★
9.8	<b>D0980</b>	3.2	41	96	10	★
10.0	<b>D1000</b>	3.2	41	96	10	★
10.1	<b>D1010</b>	3.2	41	101	12	★
10.3	<b>D1030</b>	3.2	41	101	12	★
10.5	<b>D1050</b>	3.2	41	101	12	★
10.8	<b>D1080</b>	3.7	45	105	12	★
11.0	<b>D1100</b>	3.7	45	105	12	★
11.1	<b>D1110</b>	3.7	45	105	12	★
11.5	<b>D1150</b>	3.7	45	105	12	★
11.8	<b>D1180</b>	3.7	45	105	12	★
12.0	<b>D1200</b>	3.7	49	109	12	★

★ : Со склада в Японии.

Диам. сверла D1 (мм)	Обозначение	Размеры (мм)				Наличие
		D5	L3	L1	D4	
12.5	VAPDSCBD1250	3.7	49	109	12	★
13.0	D1300	4.2	49	109	12	★
13.5	D1350	4.2	51	121	16	★
13.8	D1380	4.2	51	121	16	★
14.0	D1400	4.2	51	121	16	★
14.1	D1410	5.5	58	123	16	★
14.2	NEW D1420	5.5	58	123	16	★
14.5	NEW D1450	5.5	58	123	16	★
14.8	D1480	5.5	58	123	16	★
15.0	D1500	5.5	58	123	16	★
15.5	NEW D1550	5.5	60	125	16	★
15.7	NEW D1570	5.5	60	125	16	★
15.8	D1580	5.5	60	125	16	★
16.0	D1600	5.5	60	125	16	★
17.0	D1700	5.5	62	132	20	★
17.5	D1750	5.5	63	133	20	★
17.6	D1760	6.5	63	133	20	★
17.7	NEW D1770	6.5	63	133	20	★
17.8	D1780	6.5	63	133	20	★
18.0	D1800	6.5	63	133	20	★
18.1	D1810	6.5	65	135	20	★
19.0	D1900	6.5	65	135	20	★
19.8	D1980	7.5	67	137	20	★
20.0	D2000	7.5	67	137	20	★
20.1	D2010	7.5	67	137	20	★
21.0	NEW D2100	7.5	75	165	25	★
22.0	D2200	7.5	75	165	25	★
23.0	D2300	7.5	80	170	25	★
24.0	D2400	8.5	80	170	25	★
25.0	NEW D2500	8.5	85	180	25	★
26.0	D2600	9.0	85	180	32	★
27.0	NEW D2700	9.0	95	190	32	★
28.0	D2800	10.0	95	190	32	★
29.0	D2900	10.0	100	195	32	★
30.0	D3000	11.0	100	195	32	★
31.0	NEW D3100	11.0	105	200	32	★
32.0	D3200	13.0	105	200	32	★









### РЕКОМЕНДУЕМЫЕ РЕЖИМЫ РЕЗАНИЯ

Обработываемый материал	Конструкционная сталь, Алюминиевые сплавы		Углеродистая сталь Сk55, Легированная сталь 070M55, Ковкий чугун		Легированная инструментальная сталь, X210Cr12 (Материалы низкой твердости) Ферритная нержавеющая сталь, X10CrAl18, X10CrAl13 Мартенситная нержавеющая сталь, X20Cr13, X10CrAl13		Легированная инструментальная сталь, X40CrMoV51 (-40HRC) Нержавеющая сталь с дисперсионным упрочнением, X7CrNiAl177	
	Частота вращения (мин <sup>-1</sup> )	Подача (мм/об)	Частота вращения (мин <sup>-1</sup> )	Подача (мм/об)	Частота вращения (мин <sup>-1</sup> )	Подача (мм/об)	Частота вращения (мин <sup>-1</sup> )	Подача (мм/об)
2.0	5600	0.07	4800	0.07	3200	0.07	2800	0.04
3.0	3700	0.10	3200	0.10	2100	0.10	1900	0.05
4.0	2800	0.12	2400	0.12	1600	0.12	1400	0.06
5.0	2200	0.14	1900	0.14	1300	0.14	1150	0.07
6.0	1850	0.15	1600	0.15	1050	0.15	950	0.08
8.0	1400	0.20	1200	0.20	800	0.20	720	0.10
10.0	1100	0.23	960	0.23	640	0.21	570	0.11
12.0	950	0.26	800	0.26	530	0.24	470	0.12
14.0	800	0.27	680	0.27	450	0.25	410	0.13
16.0	700	0.28	500	0.28	360	0.26	300	0.14
18.0	620	0.29	450	0.29	320	0.27	260	0.15
20.0	560	0.30	400	0.30	290	0.27	240	0.15
22.0	510	0.32	360	0.32	260	0.29	220	0.16
24.0	460	0.33	330	0.33	240	0.30	200	0.16
26.0	430	0.35	310	0.35	220	0.31	180	0.17
28.0	400	0.36	290	0.36	210	0.33	170	0.18
30.0	370	0.37	270	0.37	190	0.34	160	0.18
32.0	350	0.38	250	0.38	180	0.35	150	0.19

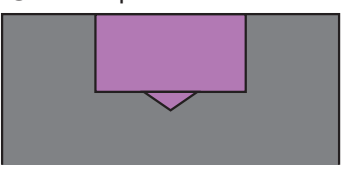
- 1) Представленные выше параметры резания предназначены для сверления отверстий глубиной до 2xD без направляющего отверстия. При сверлении отверстий глубиной менее 1xD число оборотов можно повысить на 20 %.
- 2) Рекомендуется сверление без направляющего отверстия. Отвод стружки может быть затруднён, если предварительно просверлено направляющее отверстие. Используйте режим подачи сверла с периодическим отводом из отверстия, если отвод стружки затруднён.
- 3) Для рассверливания наклонной поверхности рекомендуются использовать монолитные твердосплавные концевые фрезы.
- 4) При обработке аустенитных нержавеющих сталей (типа X5CrNi1810) скорость вращения шпинделя следует снизить на 30 - 60%, а скорость подачи - на 40 - 60%.
- 5) Для закрепления используйте цанговые патроны.
- 6) Уменьшайте число оборотов и подачу в зависимости от условий сверления, например, если системе не хватает жёсткости.
- 7) Применяйте достаточное количество СОЖ. Приведенные выше параметры резания являются ориентировочными при использовании водорастворимой СОЖ. Уменьшите число оборотов при использовании водонерастворимой СОЖ.

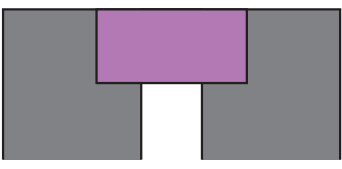
### РЕКОМЕНДУЕМАЯ ПОСЛЕДОВАТЕЛЬНОСТЬ ОБРАБОТКИ

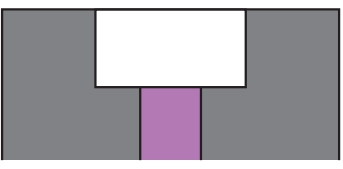
VAPDSCB обеспечивает высокоэффективную обработку с хорошим контролем стружки.

Традиционный метод обработки	Метод обработки при помощи серии VAPDSCB
<p>①Сверление отверстий под резьбу</p>  <p>Геометрия стружки</p> 	<p>①Рассверливание</p>  <p>Геометрия стружки</p> 
<p>②Рассверливание</p>  <p>Сильная закрученная стружка</p> 	<p>②Сверление отверстий под резьбу</p>  <p>Хорошее</p> 

(Примечание) При рассверливании свёрлами VAPDSCB и использовании направляющих отверстий возможно возникновение сливной стружки, которая может наматываться на инструмент.

# СВЕРЛА С АЛМАЗНЫМ CVD-ПОКРЫТИЕМ

## MCS

- Сверло серии WSTAR для обработки углепластика.
- Отверстия высокого качества в углепластике.

### Для углепластика

CFRP	Углепластик с алюминием	CFRP / многослойный с титановым сплавом
◎	◎	

	$3 < D_1 \leq 6$	$6 < D_1 \leq 10$	$10 < D_1 \leq 18$	$18 < D_1 \leq 20$
$\downarrow$	0	0	0	0
$\downarrow$	-0.018	-0.022	-0.027	-0.033
$\downarrow$	0	0	0	0
$\downarrow$	-0.008	-0.009	-0.011	-0.013

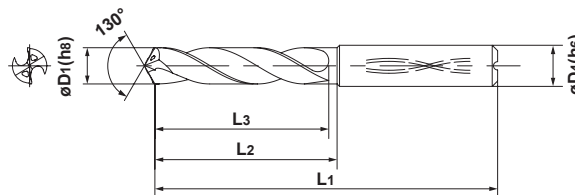

(Примечание) Сверла MCS пригодны для применения с термоматрицами.

Диам. сверла D1		Глубина сверления (l/d)	Охлаждение (Внут./Нар.)	Наличие DD2010	Обозначение	Размеры (мм)			
(дюйм)	(мм)					L3	L2	L1	D4
.1719	4.366	3	Внут.	★	MCS01719X3DB	23	28	65	6
.1915	4.864	3	Внут.	★	01915X3DB	27	28	65	6
.2510	6.375	3	Внут.	★	02510X3DB	33	41	78	8
.3125	7.938	3	Внут.	★	03125X3DB	40	41	78	8
.3760	9.550	3	Внут.	★	03760X3DB	45	46	87	10
.3765	9.563	3	Внут.	★	03765X3DB	45	46	87	10
.4380	11.125	3	Внут.	★	04380X3DB	53	54	100	12
.5010	12.725	3	Внут.	★	05010X3DB	58	59	105	14

(Примечание) По вопросам специальных артикулов и геометрий, отличающихся от наших стандартных продуктов, просьба обращаться в Mitsubishi Materials.

Для размеров, отсутствующих на складе, введите данные в  ниже.

Для заказа инструментов с геометрией, отличной от указанной, обратитесь к нам за информацией.

\*Рекомендуется твердый сплав TF15 для CFRP / титановых деталей.

Номер заказа для прямого типа

MCS     X  D

Охлаждение  
S : Внут.  
E : Нар.

Глубина сверления (l/d)  
Диапазон размеров: 2-5

Диаметр хвостовика  $\phi D_4$   
Диапазон размеров: 030-200

Диам. сверла  $\phi D_1$   
Диапазон размеров: 0300-2000  
\*Минимальный диаметр с внутренней подачей СОЖ составляет  $\phi 4$  мм ( $\phi 0,1575$  дюймов).

Диапазон диаметров сверла : 3 мм –  $\phi 20$  мм

Диапазон диаметра хвостовика :  $\phi 3$  мм –  $\phi 20$  мм

Для режущего диаметра D1 укажите 4 цифры  
Например,  $\phi 3$  мм — 0300

Для диаметра хвостовика D4 укажите 3 цифры  
Например,  $\phi 12$  мм — 120

\*Размеры в дюймах переведите в метрические  
(1 дюйм = 25,4 мм)

Пример: :  $\phi 0,3760'' \rightarrow \phi 9,550$  мм  $\rightarrow 0955$

Номер заказа для ступенчатого типа

MCS     X    X  D

Охлаждение  
S : Внут.  
E : Нар.

Диаметр для ступенчатого типа  $\phi D_c$

Глубина сверления (l/d)  
Диапазон размеров: 2-5

Диаметр хвостовика  $\phi D_4$   
Диапазон размеров: 030-200

Диам. сверла  $\phi D_1$   
Диапазон размеров: 0300-2000  
\*Минимальный диаметр с внутренней подачей СОЖ составляет  $\phi 4$  мм ( $\phi 0,1575$  дюймов).

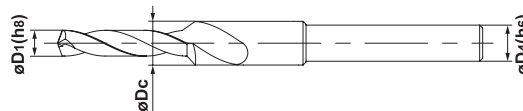

СВЕРЛЕНИЕ

★ : Со склада в Японии.

РЕЖИМЫ РЕЗАНИЯ > L186

L185

# СВЕРЛА С АЛМАЗНЫМ CVD-ПОКРЫТИЕМ

## MCS

Для углепластика

### РЕКОМЕНДУЕМЫЕ РЕЖИМЫ РЕЗАНИЯ

#### DD2010

Обрабатываемый материал		CFRP				Углепластик с алюминием			
Диам. сверла (дюйм)	Диам. сверла (мм)	Скорость резания (м/мин)	Частота вращения (мин <sup>-1</sup> )	Подача (мин. — макс.) (мм/об)	Подача (мм/мин)	Скорость резания (м/мин)	Частота вращения (мин <sup>-1</sup> )	Подача (мин. — макс.) (мм/об)	Подача (мм/мин)
<b>.1719</b>	<b>4.366</b>	85	6100	0.04 (0.03—0.08)	240	55	4000	0.04 (0.03—0.06)	160
<b>.1915</b>	<b>4.864</b>	85	5500	0.04 (0.03—0.08)	220	55	3500	0.04 (0.03—0.06)	140
<b>.251</b>	<b>6.375</b>	95	4700	0.05 (0.03—0.10)	235	65	3200	0.05 (0.03—0.07)	160
<b>.3125</b>	<b>7.938</b>	95	3800	0.05 (0.03—0.10)	190	65	2600	0.05 (0.03—0.07)	130
<b>.376</b>	<b>9.55</b>	95	3100	0.07 (0.04—0.12)	215	65	2100	0.06 (0.04—0.08)	125
<b>.3765</b>	<b>9.563</b>	95	3100	0.07 (0.04—0.12)	215	65	2100	0.06 (0.04—0.08)	125
<b>.438</b>	<b>11.125</b>	100	2800	0.1 (0.05—0.15)	280	70	2000	0.07 (0.05—0.10)	140
<b>.501</b>	<b>12.725</b>	100	2500	0.1 (0.05—0.15)	250	70	1700	0.08 (0.05—0.12)	135

#### TF15

Обрабатываемый материал		CFRP со стержнем из титанового сплава			
Диам. сверла (дюйм)	Диам. сверла (мм)	Скорость резания (м/мин)	Частота вращения (мин <sup>-1</sup> )	Подача (мин. — макс.) (мм/об)	Подача (мм/мин)
<b>.1719</b>	<b>4.366</b>	8	500	0.03 (0.02—0.04)	15
<b>.1915</b>	<b>4.864</b>	8	500	0.03 (0.02—0.04)	15
<b>.251</b>	<b>6.375</b>	8	300	0.03 (0.02—0.04)	5
<b>.3125</b>	<b>7.938</b>	8	300	0.03 (0.02—0.04)	5
<b>.376</b>	<b>9.55</b>	10	300	0.04 (0.03—0.05)	10
<b>.3765</b>	<b>9.563</b>	10	300	0.04 (0.03—0.05)	10
<b>.438</b>	<b>11.125</b>	10	200	0.04 (0.03—0.05)	5
<b>.501</b>	<b>12.725</b>	10	200	0.04 (0.03—0.05)	5